

Installation and Service Instructions for Style SCEB S3 Brakes

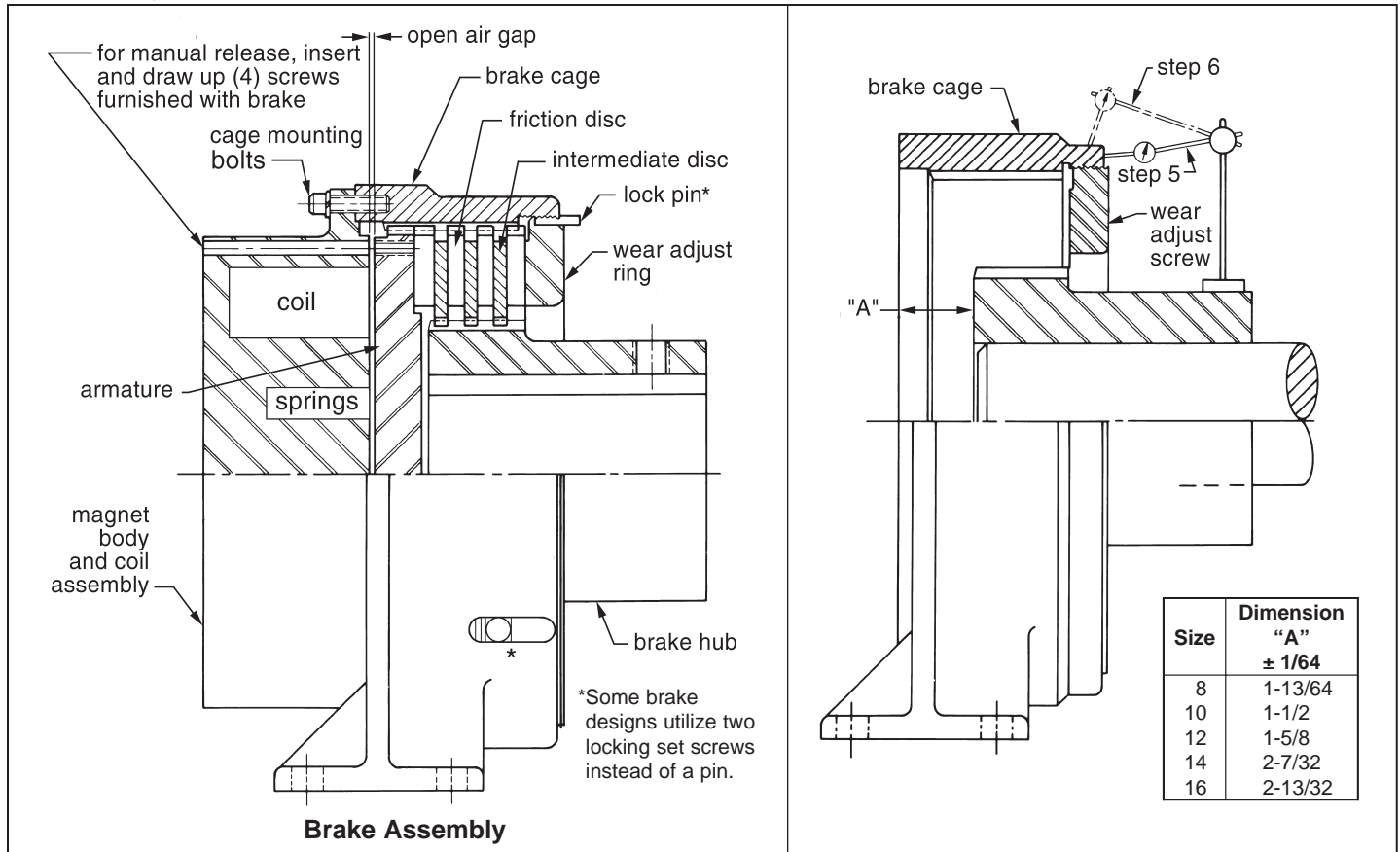

Figure 1

Figure 2

CAUTION! Armature must be secured against magnet face before removing cage mounting bolts.

1. Make a temporary lead wire connection and energize unit. Insert (4) manual release bolts clamping armature to magnet body, de-energize unit and disconnect lead wires.
2. Remove cage mounting bolts, magnet body and armature assembly, friction discs and intermediate discs.
3. Assemble brake hub to shaft.
4. With shaft leveled and aligned to machine base as desired install brake cage to Dimension "A" as shown on Figure 2.
5. Mount indicator on brake hub or on shaft and indicate face of brake cage by turning shaft. Place indicator on as great a radius as possible. This operation indicates angular misalignment and must not exceed .001" T.I.R. per inch of measuring radius.
Example: If measuring on a 6 inch radius, total indicator reading must not exceed .006".
6. Indicate machined turn on brake cage by rotating shaft. This operation indicates parallel misalignment and should not exceed .010" total indicator reading.
7. Always perform Step 5 before Step 6, since any angular misalignment which exists can introduce errors in readings for parallel misalignment. Also, after making corrective adjustments recheck both Steps 5 and 6.
8. It is recommended that the brake cage be doweled to the mounting base to prevent any shift during operation.

9. Replace friction discs and intermediate discs in order shown in Figure 1. Mount magnet body and armature to cage making certain that arrows, metal stamped on each part are in line. (**Note:** (1) hole is 1/4" offset) and tighten cage mounting screws.
10. Connect lead wires, energize unit and remove (4) manual release screws.
11. Set open air gap per *Brake Wear Adjustment*. Unit is now ready for operation.
12. The initial seating of the linings may cause some opening of the air gap. Check air gap after brake has been cycled in operation. Ordinary lining wear thereafter is very slight under normal loads. Use factory supplied feeler gauges and adjusting tool when making adjustments.

Replacement of Friction Discs

1. Energize magnet and clamp armature to magnet body with (4) manual release bolts. De-energize magnet and remove leads.
2. Remove cage mounting bolts and magnet body and armature assembly. Back off wear adjust ring slightly to allow space for new friction discs.
3. Friction discs may now be slid from hub and replaced.
4. Replace magnet body and armature assembly (arrows metal stamped on each part must be in line).
5. Reconnect lead wires, energize unit and remove (4) manual release bolts.
6. Set gap per *Brake Wear Adjustment*.

Brake Wear Adjustment

1. The operating air gap should be set to dimension shown on chart below. As lining wear continues the air gap will increase. Readjustment is recommended when the gap has increased by .015. Use factory supplied feeler gauges and adjusting tool when adjusting.
 2. To adjust for wear, depress lock pin and turn wear adjust ring clockwise until lock pin snaps into next slot.
- Note:** Flange mounted brakes use (2) set screws in the adjusting ring instead of a locking pin. Both must be removed before adjusting.
3. De-energize magnet and check open air gap.
 4. If open air gap is still too large, repeat Step 2 and 3 until desired gap is obtained.

Option: Above adjustments can be completed using (4) manual release bolts through the mag body and threading into the armature.

Unit Size	Operating Air Gap	Radjust When Gap Reaches
800	.040	.055
1000	.060	.075
1200	.060	.075
1400	.060	.075
1600	.060	.075

Pressure Spring Assembly

Sizes 800 and 1000 (free height of spring pack 3.30)

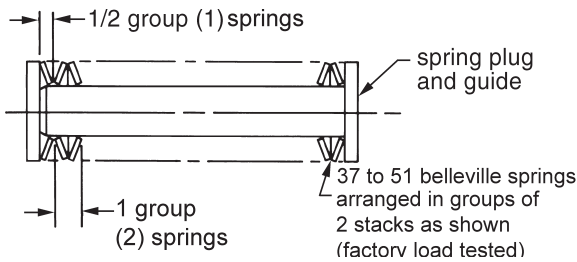

Sizes 1200, 1400 and 1600 (free height of spring pack 3.76)

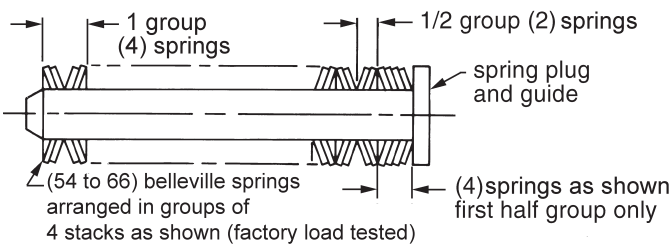

Note: Should removal of springs become necessary, they must be reassembled as shown to insure normal operation of clutch or brake.

Typical Forcing Circuit Diagram

Note: Refer to Table for circuit values.

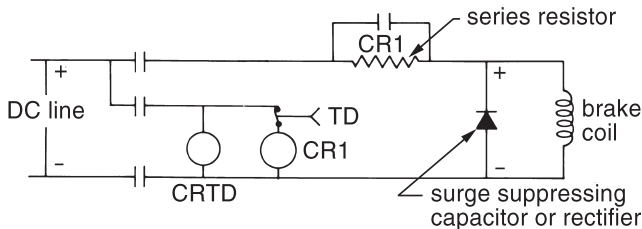

The brake coil, wound for approximately 1/3 line voltage, is momentarily engaged at line voltage. Timer, which must be set at approximately 5 seconds, then places the series resistor in the circuit, reducing the brake coil voltage and current to a *holding* current.

Circuit Values

Unit Size	DC Line Values				Clutch Coil Holding			Suggested Resistor Rating	
	Inrush		Holding		Volts	Amps	Ohms	Ohms	Watts
	Volts	Amps	Volts	Amps					
800	115	3.54	115	1.12	36.6	1.12	32.5	70	125
800	230	1.77	230	.567	74	.567	130	275	125
800	240	1.85	240	.592	77	.592	130	275	125
800	250	1.92	250	.617	80	.617	130	275	125
1000	230	2.94	230	.98	76.3	.98	78	160	250
1000	240	3.07	240	1.02	80	1.02	78	160	250
1000	250	3.19	250	1.06	83.3	1.06	78	160	250
1200	220	3.90	220	1.06	68.2	1.21	56.4	125	250
1200	230	4.08	230	1.27	71.4	1.27	56.4	125	250
1200	250	4.43	250	1.38	77.8	1.38	56.4	125	250
1200	440	1.95	440	.605	136.5	.605	225.6	500	250
1200	115	8.22	115	2.61	35.6	2.61	14.0	30	250
1400	230	3.68	230	1.16	73	1.16	62.5	135	250
1400	250	4.0	250	1.26	79	1.26	62.5	135	250
1400	220	3.52	220	1.11	69.6	1.11	62.5	135	250
1600	230	3.7	230	1.13	71	1.13	62.2	140	250
1600	250	4.02	250	1.27	79	1.27	62.2	140	250

Note: Refer to clutch nameplate for unit size and voltage.

Assembly of Magnet Body and Armature - Using Press

1. Place magnet body, with manual release bolts in holes provided in magnet body, flange side of magnet body up, on press base, with spacer as shown below.
2. Insert pressure spring assemblies, set armature in place, aligning arrows on armature and magnet body. Insert temporary pins into release bolt holes for aligning.
3. Press armature against magnet body (see Table for pressure required) remove (4) temporary pins and install (4) manual release bolts and tighten to hold armature against magnet body.

Disassembly Procedure

1. Place assembly on press with spacer.
2. Press armature against magnet body (see Table for pressure required) and remove manual release bolts from armature.
3. Slowly release pressure from press until spring pressure is relieved and remove armature. Pressure spring assemblies may now be removed.

