

Parts List for 56,7X3 Series Brakes

Information required when ordering replacement parts:

- Give part number of parts or kits needed, brake model number, and brake serial number. The brake model and serial number may identify special brakes not covered by this parts list.

Tools required for installation and servicing:

- | | |
|------------------|----------------------|
| 3/8" hex wrench | 5/16" nut driver |
| 5/16" hex wrench | 1/4" screwdriver |
| 3/16" hex wrench | 8" adjustable wrench |

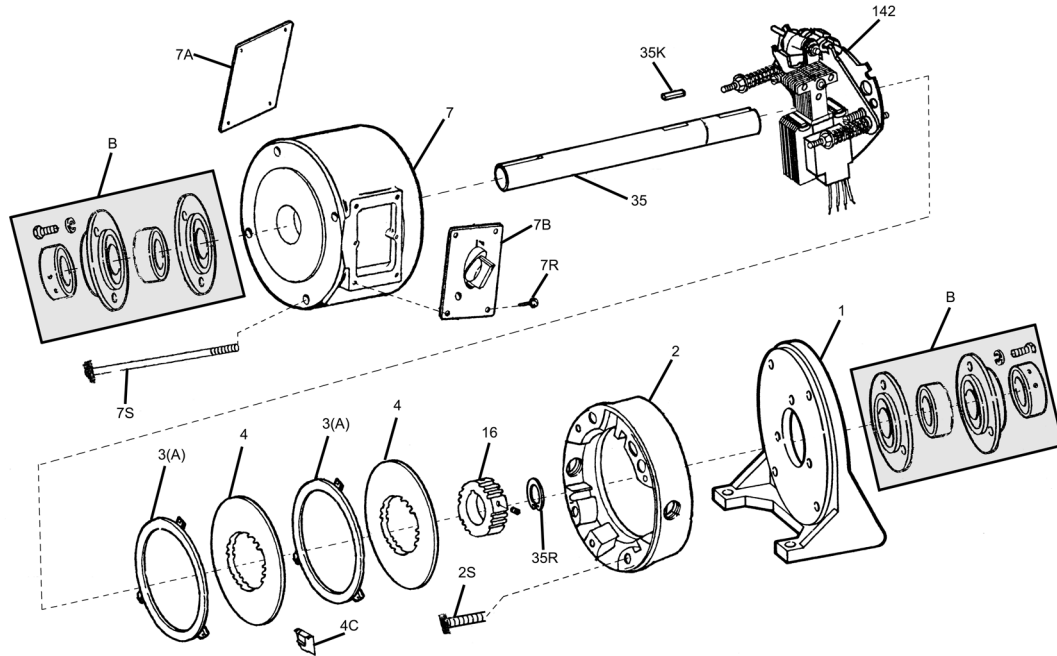

Typical Nameplate

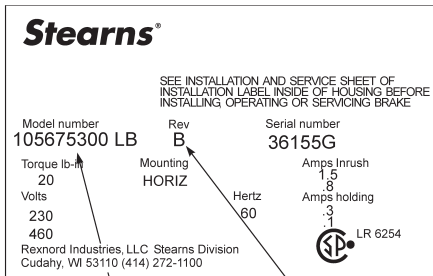

MODEL NUMBER will appear on brake nameplate

REVISION CONTROL

Important

Please read these instructions carefully before installing, operating, or servicing your Stearns Brake. Failure to comply with these instructions could cause injury to personnel and/or damage to property if the brake is installed or operated incorrectly. For definition of limited warranty/liability, contact Rexnord Industries, LLC, Stearns Division, 5150 S. International Dr., Cudahy, WI 53110, (414) 272-1100.

Caution

1. Installation and servicing must be made in compliance with all local safety codes including Occupational

Safety and Health Act (OSHA). All wiring and electrical connections must comply with the National Electric Code (NEC) and local electric codes in effect.

2. Do not install the brake in atmospheres containing explosive gases or dusts.
3. To prevent an electrical hazard, disconnect power source before working on the brake. If power disconnect point is out of sight, lock disconnect in the *off* position and tag to prevent accidental application of power.
4. Make certain power source conforms to the requirements specified on the brake nameplate.
5. Be careful when touching the exterior of an operating brake. Allow sufficient time for brake to cool before disassembly. Surfaces may be hot enough to be painful or cause injury.
6. Do not operate brake with housing removed. All moving parts should be guarded.
7. Installation and servicing should be performed only by qualified personnel familiar with the construction and operation of the brake.

8. For proper performance and operation, only genuine Stearns parts should be used for repairs and replacements.

9. After usage, the brake interior will contain burnt and degraded friction material dust. This dust must be removed before servicing or adjusting the brake.

DO NOT BLOW OFF DUST using an air hose. It is important to avoid dispersing dust into the air or inhaling it, as this may be dangerous to your health.

- a) Wear a filtered mask or a respirator while removing dust from the inside of a brake.
- b) Use a vacuum cleaner or a soft brush to remove dust from the brake. When brushing, avoid causing the dust to become airborne. Collect the dust in a container, such as a bag, which can be sealed off.

Caution! While the brake is equipped with a manual release to allow manual shaft rotation, the motor should not be run with the manual release engaged, to avoid overheating the friction disc(s).

Table 1

NEMA 2

			1.5 1-056-703-00	3 1-056-713-00	6 1-056-723-00	10 1-056-733-00	15 1-056-743-00	20 1-056-753-00	25 1-056-763-00
1	Floor Stand	8-034-502-01	1	1	1	1	1	1	1
2	Endplate	5-02-5035-00 5-02-5036-00	1	1	1	1	1	1	1
2S	Mounting Screws 1.75"	9-17-1228-00	2	2	2	2	2	2	2
B	Bearing Kit	5-96-7203-00	2	2	2	2	2	2	2
3/3A	Stationary Disc	5-66-8354-00 5-66-8355-00	1	1	1	1	1	3	3
4	Friction Disc	5-66-8462-00	1	1	1	2	2	3	3
4C	Stabilizer Clip	Part of 5-66-8462-00	2	2	2	---	---	---	---
16	Hub	5-16-5150-00-01D 5-16-5153-00-01D	1	1	1	1	1	1	1
35	Brake Shaft	8-035-568-00	1	1	1	1	1	1	1
35K	Hub Key	9-50-0821-00	1	1	1	1	1	1	1
35R	Retaining Ring	9-03-0062-00	1	1	1	1	1	1	1
7	Housing	8-007-527-14	1	1	1	1	1	1	1
7A	Access Cover	8-104-505-00	1	1	1	1	1	1	1
7B	Manual Release Assembly	5-07-5033-00	1	1	1	1	1	1	1
7R	Access Cover Screws	9-25-7321-00	4	4	4	4	4	4	4
7S	Housing Bolts	9-15-1025-00	2	2	2	2	2	2	2
Not Shown	Vertical Spring Kit	5-63-0525-00	*	*	*	1	1	1	1
142	Support Plate	SEE TABLE 2							

* Single disc brakes do not require vertical modification.

Support Plate Assembly

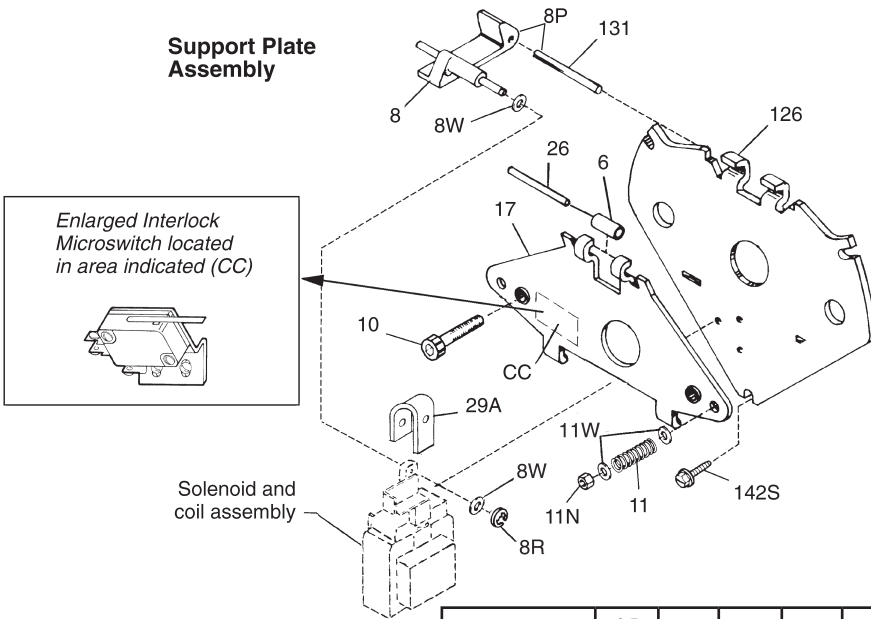

Solenoid and Coil Assembly

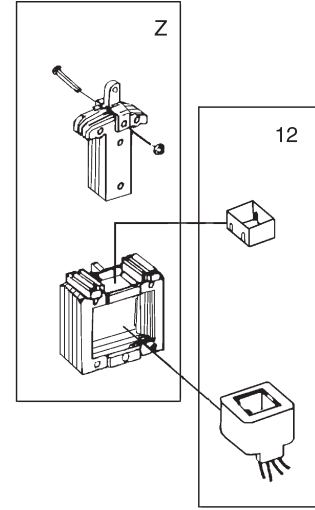

TABLE 2
Components of Support Plate and Coil Assembly

Item	Description	Part Number ↓	Torque (lb-ft)						
			1.5 & 3	6	10	15	20	25	
Support Plate Assy. (Items 6 through 131 and Z) →			5-42-5622-00-14 (AC)	5-42-5623-00-14 (AC)	5-42-5624-00-14 (AC)	5-42-5625-00-14 (AC)	5-42-5626-00-14 (AC)	5-42-5626-00-14 (AC)	
6	Bearing	8-006-501-00	1	1	1	1	1	1	
8	Solenoid Lever	8-008-504-01	1	1	1	1	1	1	
8P	Solenoid Lever & Pin Assembly	8-008-507-00	1	1	1	1	1	1	
8R	Retaining Ring	9-03-0057-00	1	1	1	1	1	1	
8W	Spacer	9-45-0168-00	2	2	2	2	2	2	
11N	Torque Adjustment Nut	9-40-3928-00	2	2	2	2	2	2	
10	Wear Adjustment Screw	9-17-8420-00	2	2	2	2	2	2	
11	Pressure Spring	9-70-1215-00	2	2					
	Pressure Spring	9-70-1523-00			2	2	2	2	
	Pressure Spring	9-70-1524-00			2	2	2	2	
11W	Spring Washer	9-46-0010-00			4	4	4	4	
17	Lever Arm & Stop Nut Assembly	5-17-5011-00	1	1	1	1	1	1	
26	Bearing Pin	9-29-4826-00	1	1	1	1	1	1	
29A	Plunger Stop	8-094-503-00	1	1	1	1	1	1	
126	Support Plate & Spring Stud Assembly	5-26-5021-00	1	1	1	1	1	1	
131	Pivot Pin	9-29-4836-00		1	1	1	1	1	
142S	Mounting Screws	9-25-9013-00	3	3	3	3	3	3	
AC Brakes									
Z	No. 4 Solenoid Kit	5-96-5047-01	1	1	1	1	1	1	
12**	No. 4 Coil Kit	115/230 Vac	5-96-6479-59	1	1	1	1	1	
		230/460 Vac	5-96-6479-70	1	1	1	1	1	
		115 Vac	5-96-6479-52	1	1	1	1	1	
		230 Vac	5-96-6479-58	1	1	1	1	1	
		460 Vac	5-96-6479-68	1	1	1	1	1	
	575 Vac	5-96-6479-74	1	1	1	1	1		
CC	Brake Release Interlock Switch (optional)	5-57-5526-00	1	1	1	1	1		

TABLE 3
Contents of Kits and Assemblies

Letter Designation	Kit Description
3	Stationary Disc Kit (5-66-8354-00) 1 - Stationary Disc
3A	Stationary Disc Kit (5-66-8355-00) 2 - Stationary Discs with Springs
4	Friction Disc Kit (5-66-8462-00) 1 - Friction Disc 2 - Stabilizing Springs (for 1-1/2 - 6 lb-ft brake use only)
Z	No. 4 solenoid Kit (5-96-5047-01) 1 - Plunger 1 - Solenoid Link 1 - Frame (including mounting bracket) 1 - Solenoid Link Cap Screw 1 - Solenoid Link Nut 3 - Solenoid Mounting Screws
12	No. 4 AC Coil Kit (5-96-6479-XX) Coil Top Plunger Guide Wire Nut
CC	Brake Release Interlock Switch (5-57-5526-00) 1 - Microswitch 1 - Mounting Bracket 2 - Bracket Mounting Screws 2 - Switch Mounting Screws 2 - Lead Wire Assembly

Optional Modification Kits

TABLE 4

Catalog Mod Number	Description	Part Number ↓	Torque (lb-ft)	1.5, 3 & 6	10 & 15	20 & 25
			Brake Model Number →	1-056-70X-00 1-056-71X-00 1-056-72X-00	1-056-73X-00 1-056-74X-00	1-056-75X-00 1-056-76X-00
M4	Brass Stationary Disc	8-003-513-02		1	2	3
M13	Space Heater 115 VAC 230 VAC	5-27-2004-00		1	1	1
		5-27-2005-00		1	1	1
M17	Terminal Strip	5-63-0524-00		1	1	1
M21	Vertical Spring Kit (2 disc) (3 disc)	5-63-0539-00			1	
		5-63-0525-00				1



Rexnord Industries, LLC
 Stearns Division
 5150 S. International Drive
 Cudahy, Wisconsin 53110
 (414) 272-1100 Fax: (414) 277-4364 www.stearns.rexnord.com