

Parts List for 65,300-07 and 65,300-09 Series Brakes

Information required when ordering replacement parts:

- When ordering brake parts, give part number of parts or kits needed, brake model number, and brake serial number. The brake model and serial number may identify special brakes not covered by this parts list.
- When ordering hubs, specify shaft diameter (hub bore) and keyway.
- For installation and service instructions, see P/N 8-078-925-09. Detailed service instruction sheet is included with each kit.

Note:

- This brake series is listed by UL (Underwriters Laboratories) for use in certain locations classified as hazardous. Installation and servicing

must be in compliance with all existing local safety codes. All wiring and electrical connections must comply with the National Electric Code (NEC) and local electrical codes in effect at the time. For additional information see the Underwriters Laboratories (UL) website <http://www.ul.com/hazloc/codes/html>.

- HazLoc inspection authorities are responsible for verifying and authorizing the use of suitably designed, manufactured and installed HazLoc equipment. When questions arise always consult the local Authority Having Jurisdiction (AHJ) for directions and approvals.

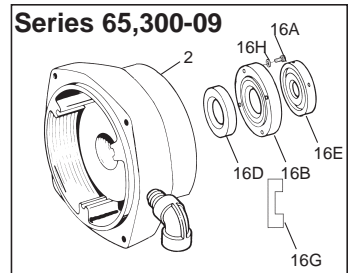
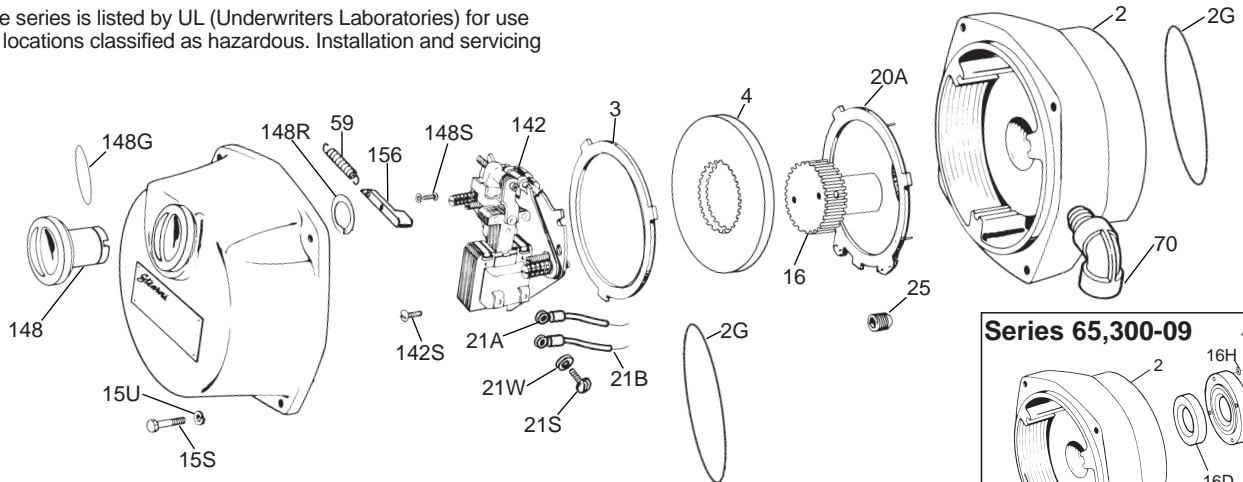

TABLE 1

Item	Description	Part Number↓	Non-Slinger Mount					Slinger Mount					
			Torque (lb-ft)	1.5	3	6	10	15	1.5	3	6	10	15
2	Endplate assembly	5-50-5205-00	1	1	1	1	1	1	1	1	1	1	1
16	Hub	5-16-5015-00	1	1	1	1	1	1	1	1	1	1	1
16A	1/4-20 x 5/8 cap screw	9-17-1010-00						4	4	4	4	4	4
16B	Bearing cover	8-103-504-00						1	1	1	1	1	1
16H	1/4" washer	9-45-1330-00						4	4	4	4	4	4
16D	Bearing	9-01-6506-00						1	1	1	1	1	1
16E	Slinger	8-103-503-00*						1	1	1	1	1	1
16G	Slinger template	8-141-506-00						1	1	1	1	1	1
3	Stationary disc kit	5-66-8354-00	1	1	1	1	1	1	1	1	1	1	1
3A		5-66-8355-00											
4	Friction disc kit	5-66-8458-00	1	1	1	2	2	1	1	1	2	2	2
7	Housing assembly	5-07-5015-00	1	1	1	1	1	1	1	1	1	1	1
148	Release knob (part of #7)	8-148-504-04	1	1	1	1	1	1	1	1	1	1	1
148G	Release knob O-ring	8-073-002-12	1	1	1	1	1	1	1	1	1	1	1
15S	Capscrew 3/8" x 16	9-17-3220-00	4	4	4	4	4	4	4	4	4	4	4
156	Washer 3/8"	9-45-1332-00	4	4	4	4	4	4	4	4	4	4	4
20A	Insulator disc (part of #2)	8-003-504-01	1	1	1	1	1	1	1	1	1	1	1
20P	Spirol pin	9-32-2003-00	3	3	3	3	3	3	3	3	3	3	3
21A	Thermostat N.C. (red leads)	5-57-5001-00	1	1	1	1	1	1	1	1	1	1	1
21B	Thermostat N.O. (yellow leads)	5-57-5002-00	1	1	1	1	1	1	1	1	1	1	1
21S	Machine screw 5-40 x 1/4	9-13-3083-00	4	4	4	4	4	4	4	4	4	4	4
21W	Lockwasher #5	9-45-0325-00	4	4	4	4	4	4	4	4	4	4	4
25	Set screw 3/4 x 16	9-23-0023-00	4	4	4	4	4	4	4	4	4	4	4
70	Elbow	9-33-3004-00	1	1	1	1	1	1	1	1	1	1	1
142	Support plate assembly (less coil)	5-42-5632-00-14 5-42-5633-00-14 5-42-5634-00-14 5-42-5635-00-14	1	1	1	1	1	1	1	1	1	1	1
142S	Threading screw	9-25-9013-00	3	3	3	3	3	3	3	3	3	3	3
59	Release spring	9-71-0005-00	1	1	1	1	1	1	1	1	1	1	1
156	Release arm	8-156-510-00	1	1	1	1	1	1	1	1	1	1	1
148	Release knob	8-148-504-04	1	1	1	1	1	1	1	1	1	1	1
148R	Retaining ring	9-03-0001-00	1	1	1	1	1	1	1	1	1	1	1
148S	Machine screw	9-10-2706-00	1	1	1	1	1	1	1	1	1	1	1
NOT SHOWN	Vertical spring kit	5-63-0539-00									1	1	1
2G	O-Ring kit (NEMA 4)	5-63-0540-00	1	1	1	1	1	1	1	1	1	1	1
	O-Ring kit (NEMA 2)	5-63-0541-00	1	1	1	1	1	1	1	1	1	1	1

* Motor shaft diameter is required to select proper slinger size.

** X = 1 is a NEMA 2 Enclosure
X = 2 is a NEMA 4 Enclosure

Support Plate Assembly

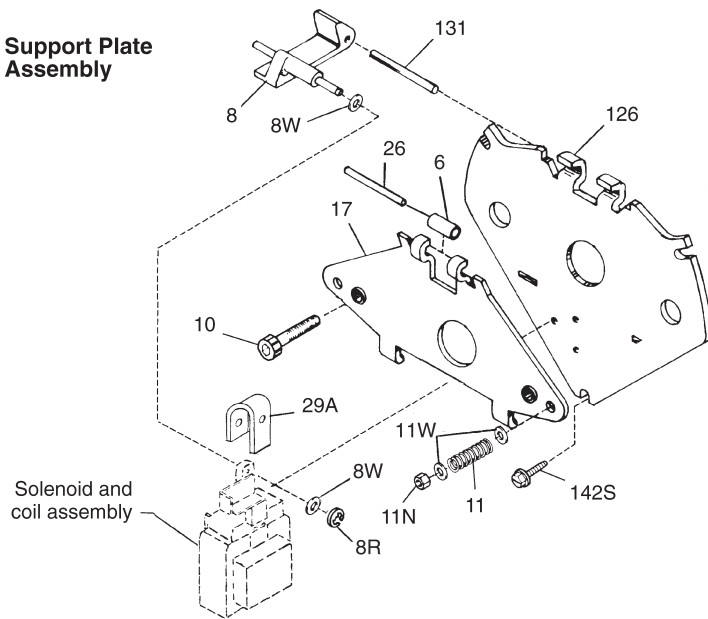

TABLE 2
Components of Support Plate and Coil Assembly

Item	Description	Part Number	Torque (lb-ft)			
			1.5 & 3	6 & 10	15	
			Support Plate Assy.			
			5-42-5574-00	5-42-5575-00	5-42-5576-00	
6	Bearing	8-006-501-00	1	1	1	
8	Solenoid lever	8-008-504-01	1	1	1	
8R	Retaining ring	9-03-0057-00	1	1	1	
8W	Spacer	9-45-0168-00	2	2	2	
11N	Torque adjustment nut	9-40-3928-00	2	2	2	
10	Wear adjustment screw	9-17-8420-00	2	2	2	
11	Pressure spring	9-70-1215-00	2			
	Pressure spring	9-70-1523-00		2		
	Pressure spring	9-70-1524-00			2	
11W	Spring washer	9-46-0010-00		4	4	
17	Lever arm and stop nut assembly	5-17-5011-00	1	1	1	
26	Bearing pin	9-29-4826-00	1	1	1	
29A	Plunger stop	8-094-503-00	1	1	1	
126	Support plate and spring stud assembly	5-26-5021-00	1	1	1	
131	Pivot pin	9-29-4836-00	1	1	1	
142S	Mounting screws	9-25-9013-00	3	3	3	
Z	No. 4 solenoid kit	5-66-5042-00	1	1	1	
12	No. 4 coil kit 60 Hz	115/230 Vac	5-96-6407-05	1		
		230/460 Vac	5-96-6409-05	1		
		115 Vac	5-96-6401-05	1		
		230 Vac	5-96-6402-05	1		
		460 Vac	5-96-6404-05	1		
		575 Vac	5-96-6405-05	1		
	No. K4 coil kit 60 Hz	115/230 Vac	5-96-6457-05		1	
		230/460 Vac	5-96-6459-05		1	
		115 Vac	5-96-6451-05		1	
		230 Vac	5-96-6452-05		1	
		460 Vac	5-96-6454-05		1	
		575 Vac	5-96-6455-05		1	
	No. K4+ coil kit 60 Hz	115/230 Vac	5-96-6407-25			1
		230/460 Vac	5-96-6409-25			1
		115 Vac	5-96-6401-25			1
		230 Vac	5-96-6402-25			1
		460 Vac	5-96-6404-25			1
		575 Vac	5-96-6405-25			1

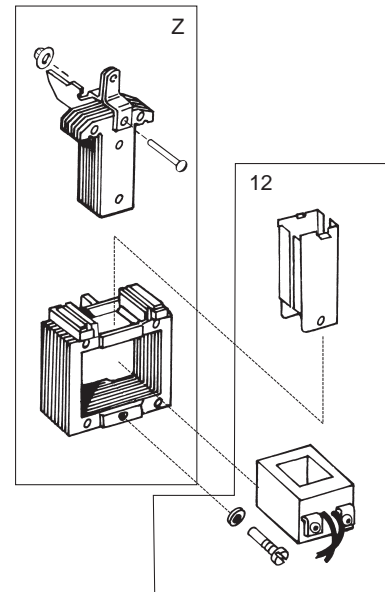

TABLE 3
Contents of Kits and Assemblies

Item Designation	Kit Description
3	Stationary disc kit (5-66-8354-00) 1 - Stationary disc
3A	Stationary disc kit (5-66-8355-00) 2 - Stationary discs with springs
4	Friction disc kit (5-66-8458-00) 1 - Friction disc
Z	No. 4 solenoid kit (5-66-5042-00) 1 - Plunger 1 - Solenoid link 1 - Frame 1 - Solenoid link cap screw 1 - Solenoid link nut 3 - Solenoid mounting screws
12	No. 4 AC coil kit (5-96-64XX-X5) Coil Plunger guides Wire nut
not shown	Vertical spring kit (5-64-5039-00) 6 - Copper springs 1 - Insertion tool
2G	NEMA 4 Gasket kit (5-63-0540-00) 1 - Housing to endplate gasket 1 - Endplate to motor gasket
	NEMA 2 Gasket kit (5-63-0541-00) 1 - Endplate to motor gasket



Rexnord Industries, LLC
Stearns Division
5150 International Dr.
Cudahy, WI 53110
(414) 272-1100 Fax: (414) 277-4364

www.stearnsbrakes.com