

Parts List for 55,400 Series Brakes

Information required when ordering replacement parts:

- Give part number of parts or kits needed, brake model number, and brake serial number. The brake model and serial number may identify special brakes not covered by this parts list.
- When ordering hubs, specify shaft diameter (hub bore) and keyway. Consult factory for bores not listed.
- Enclosures are designated as follows:
O = Standard
E = Dust-tight, waterproof (DTWP)

General Information

- For installation and service instructions, see P/N 8-078-925-00.
- Detailed service instruction sheet is included with each kit.

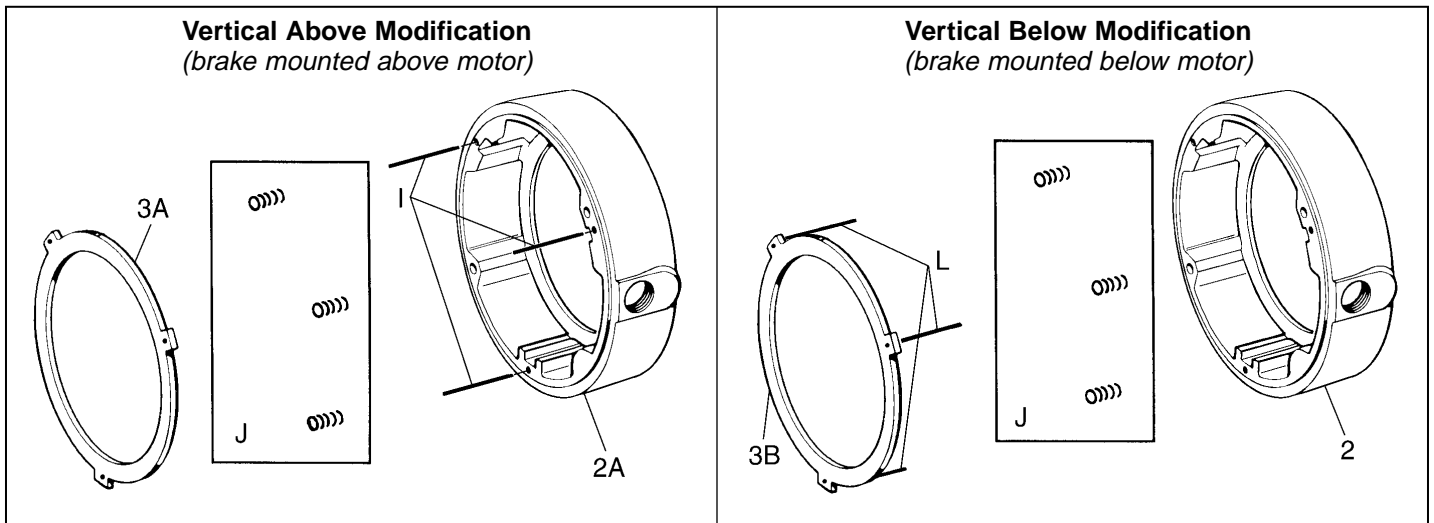
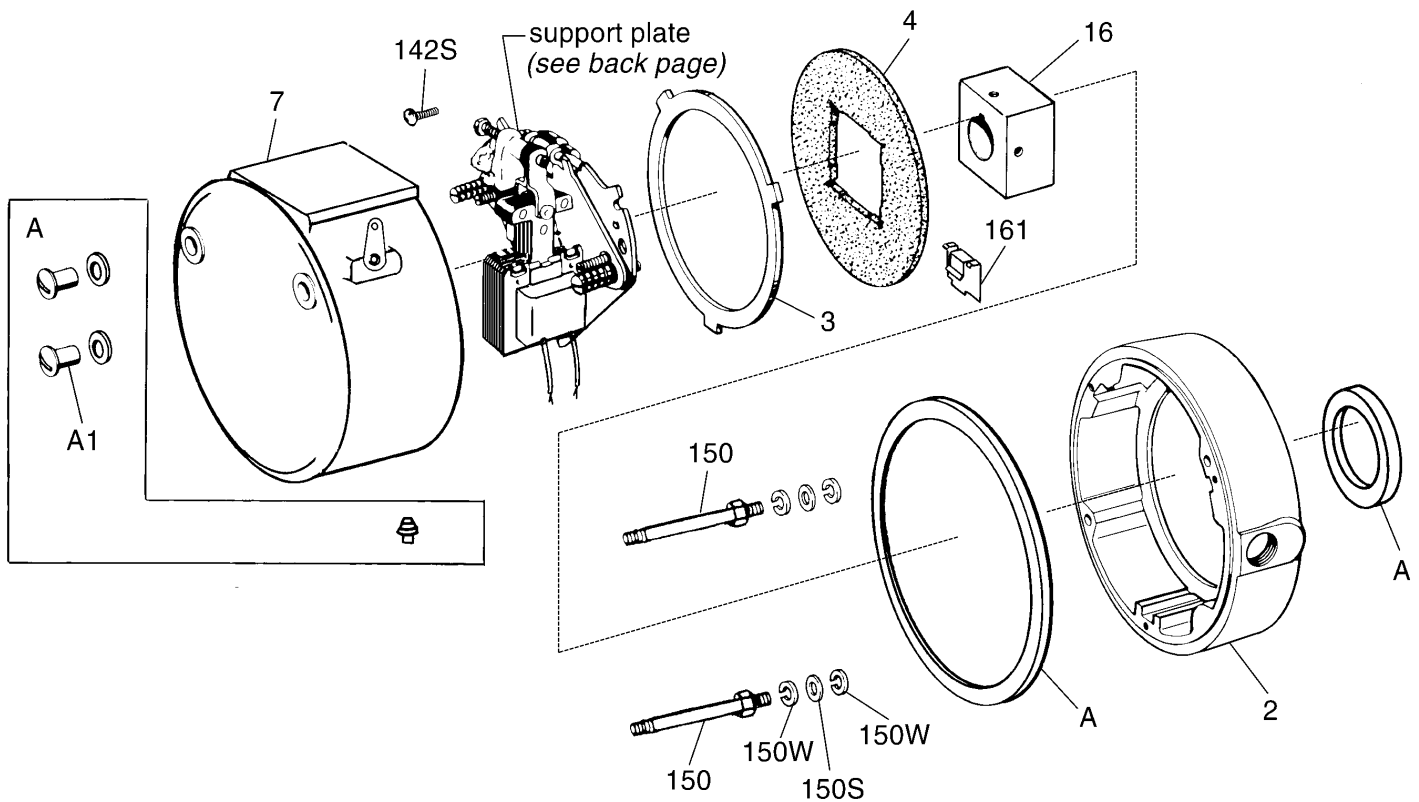

Support Plate Assembly

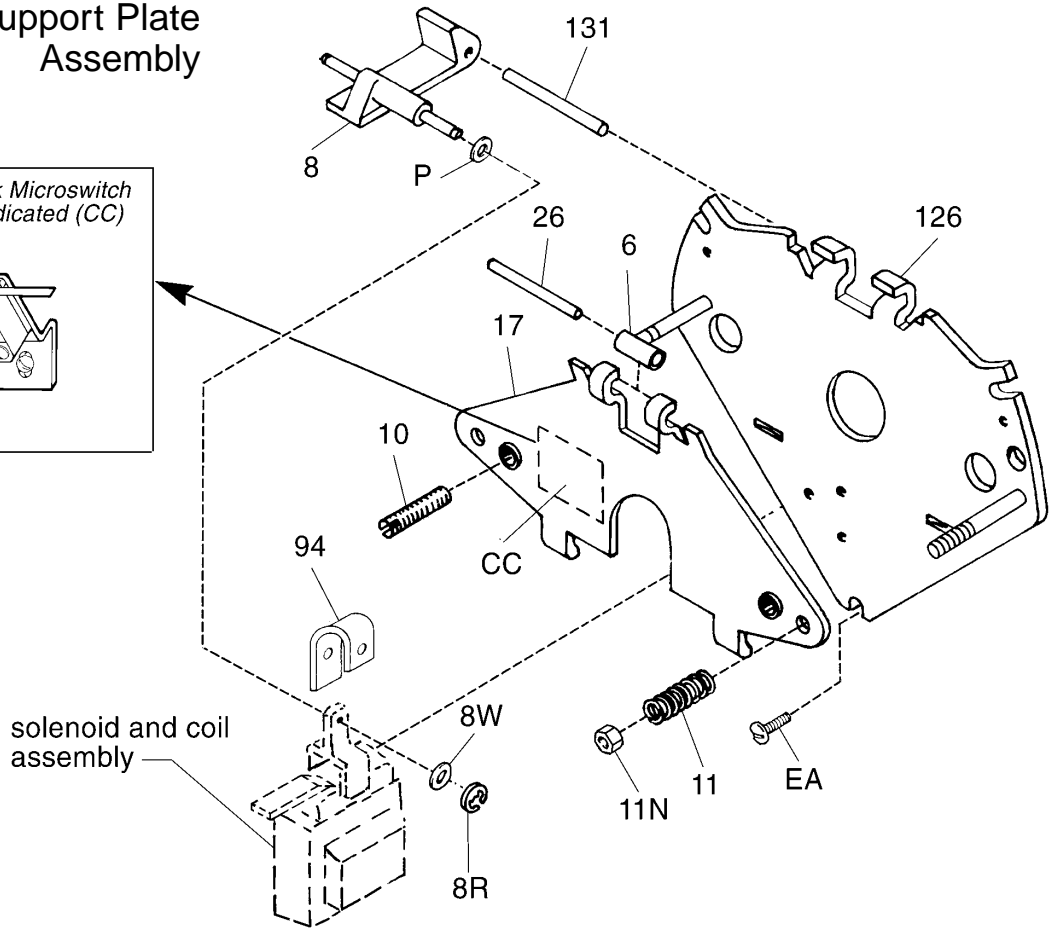
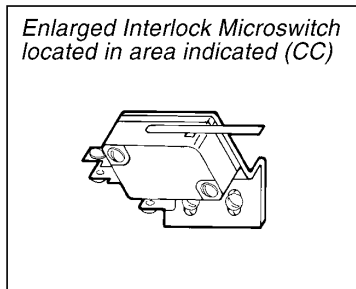

TABLE 2

Components of Support Plate and Coil Assembly

Item	Description	Part Number	1.5 through 15 lb-ft
<i>not shown</i>	Support plate assembly (Items M through Y and EA)	5-42-5542-00	1
6	Bearing	8-006-501-00	1
8	Solenoid lever	8-008-504-01	1
8R	Retaining ring	9-03-0057-00	1
8W	Spacer	9-45-0168-00	2
11N	Torque adjustment nut	9-40-3928-00	2
10	Wear adjustment screw	8-100-501-00	2
11	Pressure spring	9-70-1302-00	2
17	Lever arm and stopnut assembly	5-17-5002-00	1
26	Bearing pin	9-29-4826-00	1
94	Plunger stop	8-094-504-00	1
126	Support plate and spring stud assy.	5-26-5013-00	1
131	Mounting screws	9-29-4836-00	1
142S	Mounting screws	9-25-7331-00	3

Item	Description	Part Number	1.5 through 15 lb-ft	
AC Brakes				
Z	No. 4 solenoid assembly	5-12-5549-00	1	
AA	No.4 Coil Kit	115/230 Vac	5-66-6407-33	1
		230/460 Vac	5-66-6409-33	1
		115 Vac	5-66-6401-33	1
		230 Vac	5-66-6402-33	1
		460 Vac	5-66-6404-33	1
	575 Vac	5-66-6405-33	1	
CC	Interlock microswitch	5-57-5515-00	1	
DC Brakes				
AA	No. 4 Coil Assembly	115 Vdc	5-96-6416-33	1
		230 Vdc	5-96-6417-33	1
BB	Electronic DC Switch Kit	24/28 Vdc	5-57-5712-05	1
		115 Vdc	5-57-5716-05	1
		230 Vdc	5-57-5717-05	1

Solenoid and Coil

TABLE 3

Contents of Kits and Assemblies (contents may vary)

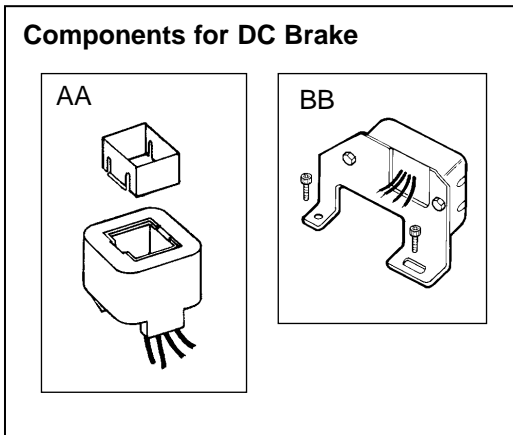
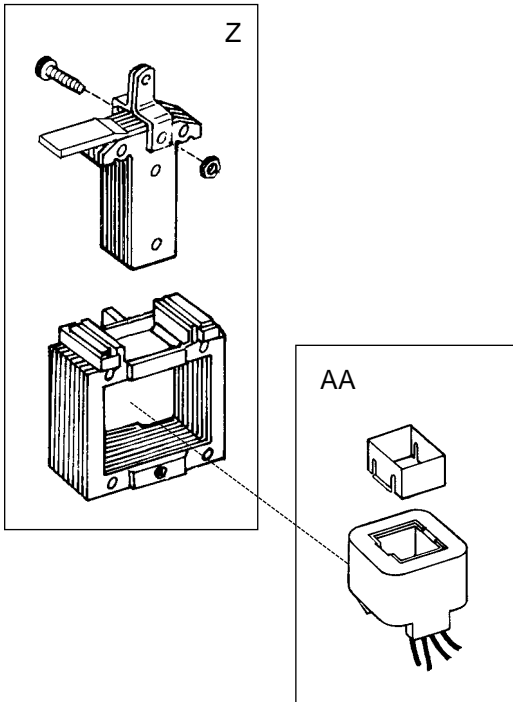

Letter Designation	Kit Description
A	Hardware kit - DTWP brake (5-63-5501-00) 1 - Endplate oil seal 1 - Drain plug 2 - Housing nuts 2 - Housing nut gaskets 1 - Housing-to-endplate gasket
3	Stationary disc kit (5-66-8351-00) 1 - Stationary disc
4	Friction disc kit (5-66-8452-00) 1 - Friction disc
16	Hub and set screw assemblies (all types) - all bores (5-16-51XX-00) 1 - Brake hub 2 - Set screws
3A	Stationary disc kit - vertical mounting (5-66-8352-00) 1 - Stationary disc for vertical above or below mounting
J	Vertical mounting spring kit - blue (5-66-3151-00) 3 - Vertical mounting springs - blue
	Vertical mounting spring kit - white (5-66-3152-00) 3 - Vertical mounting springs - white
	Vertical mounting spring kit - red (5-66-3153-00) 3 - Vertical mounting springs - red
3B	Pressure plate kit - vertical mounting (5-66-8553-00) 1 - Pressure plate - vertical below
Z	No. 4 solenoid kit (5-12-5549-00) 1 - Plunger 1 - Solenoid link 1 - Frame 1 - Solenoid link cap screw 1 - Solenoid link nut 3 - Solenoid mounting screws
AA	No. 4 coil kit (5-66-64XX-33) and assembly (5-96-64XX-33) all voltages 1 - Coil 2 - Top plunger guide Wire nuts } <i>where</i> Crimp terminals } <i>required</i>
BB	DC switch kit (5-57-57XX-05) 1 - Switch 1 - Mounting bracket 2 - Support plate mounting screws 2 - Switch mounting screws 2 - Nuts 3 - Crimp connectors
CC	Interlock microswitch (5-57-5515-00) 1 - Microswitch 1 - Mounting bracket 4 - Screws 2 - Lock washers 2 - Star washers 2 - Nuts