

Parts List for 55,700 Double C-Face Coupler

With 1985 design brake shaft (35) and hub (16) coupled to motor shaft.

Information required when ordering replacement parts:

- Give part number of parts or kits needed, brake model number, and brake serial number. The brake model and serial number may identify special brakes not covered by this parts list.
- When ordering hubs, specify shaft diameter (hub bore) and keyway.
- Enclosures are designed as follows:
O = Standard
E = Dust-tight, waterproof (DTWP)

For installation and service instructions see P/N 8-078-925-07.

Detailed service instruction sheet is included with each kit.

Obsolete
Since 1995
Limited Parts Available

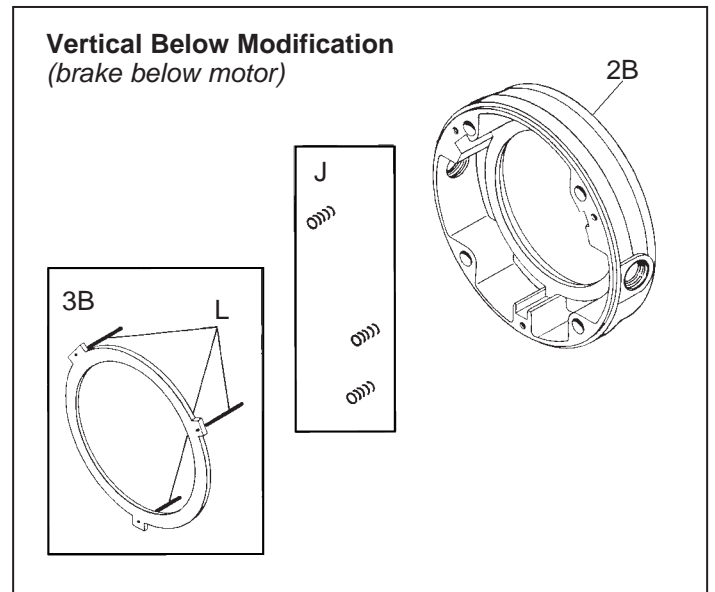
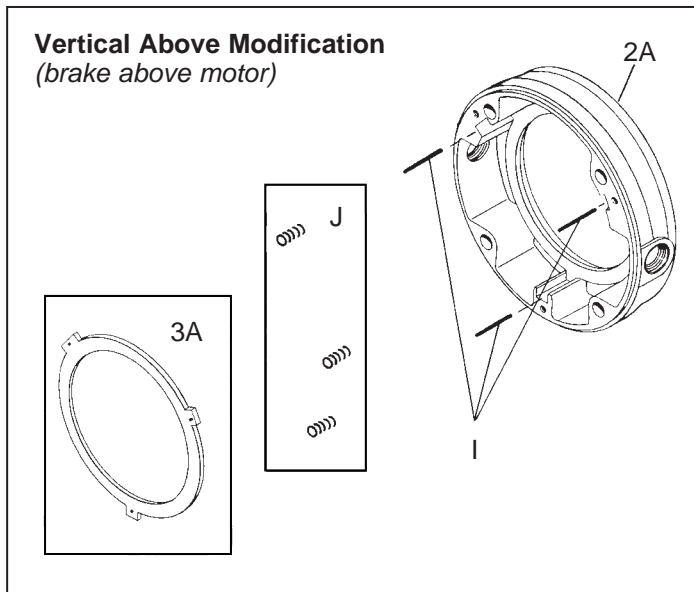
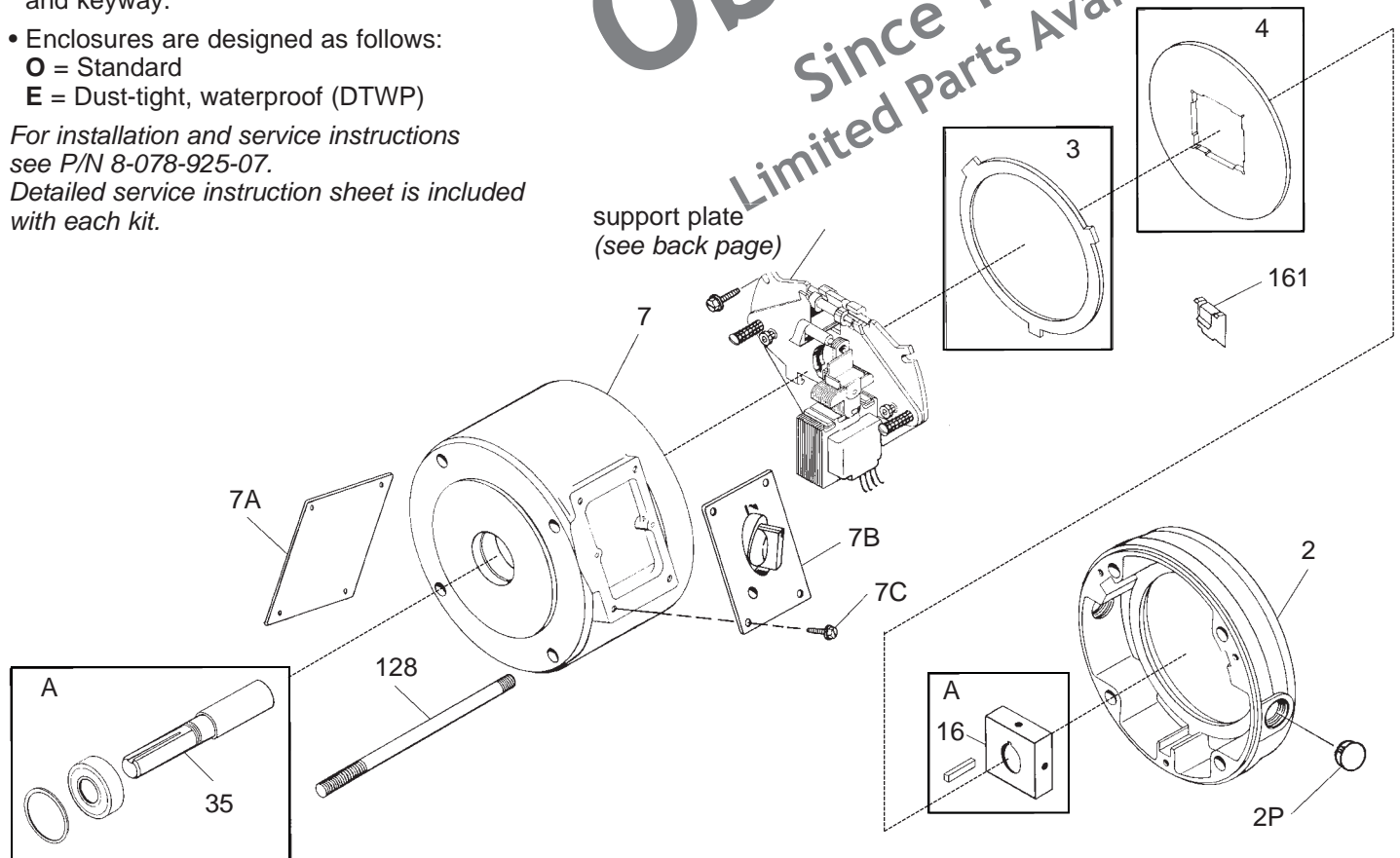

TABLE 1
Components of Standard AC or DC Brakes

		Torque (lb-ft)	1.5				3				6				10				15																							
		Current	AC		DC		AC		DC		AC		DC		AC		DC		AC		DC																					
		Enclosure	O	E	O	E	O	E	O	E	O	E	O	E	O	E	O	E	O	E	O	E																				
		Brake Model Number* →	1-055-701-XX		1-055-702-XX		1-055-705-XX		1-055-706-XX		1-055-711-XX		1-055-712-XX		1-055-715-XX		1-055-716-XX		1-055-721-XX		1-055-722-XX		1-055-725-XX		1-055-726-XX		1-055-741-XX		1-055-742-XX		1-055-745-XX		1-055-746-XX		1-055-751-XX		1-055-752-XX		1-055-755-XX		1-055-756-XX	
Item	Description	Part Number ↓	Obsolete																																							
A	Coupler brake shaft kit 5/8" shaft diameter 7/8" shaft diameter		Obsolete																																							
7	Housing - standard brake 5/8" shaft diameter 7/8" shaft diameter		Obsolete																																							
	Housing - DTWP brake 5/8" shaft diameter 7/8" shaft diameter		Obsolete																																							
128	Mounting stud	5-96-0527-00	1	1	1	1	1	1	1	1	1	1	1	1	1	1	1	1	1	1	1	1	1	1	1	1	1	1	1	1	1	1	1	1	1	1	1	1	1	1	1	
7A	Access cover - standard brake	8-104-505-00	1		1		1		1		1		1		1		1		1		1		1		1		1		1		1		1		1		1		1		1	
	Access cover - DTWP brake	8-104-506-00		1		1																		1																		
7B	Manual release assembly (cover)	5-07-5033-00	1		1		1		1		1		1		1		1		1		1		1		1		1		1		1		1		1		1		1		1	
7C	Machine screw	9-25-7321-00	8	12	8	12	8	12	8	12	8	12	8	12	8	12	8	12	8	12	8	12	8	12	8	12	8	12	8	12	8	12	8	12	8	12	8	12	8	12	8	12
<i>not shown</i>	Gasket - access cover	8-073-504-00		2		2		2		2		2		2		2		2		2		2		2		2		2		2		2		2		2		2		2		
	Pipe plug - drain	9-33-0325-00		1		1		1		1		1		1		1		1		1		1		1		1		1		1		1		1		1		1		1		
3	Stationary disc kit	5-66-8351-00	1	1	1	1	1	1	1	1	1	1	1	1	1	1	1	1	1	1	1	1	2	2	2	2	2	2	2	2	2	2	2	2	2	2	2	2	2	2	2	
4	Friction disc kit	5-66-8452-00	1	1	1	1	1	1	1	1	1	1	1	1	1	1	1	1	1	1	1	1	2	2	2	2	2	2	2	2	2	2	2	2	2	2	2	2	2	2	2	
161	Stabilizing spring	8-161-501-00	2	2	2	2	2	2	2	2	2	2	2	2	2	2	2	2	2	2	2	2	2	2	2	2	2	2	2	2	2	2	2	2	2	2	2	2	2	2	2	
2	Endplate assembly		Obsolete																																							
2P	Pipe plug - external lead holes		Obsolete																																							
<i>not shown</i>	Gasket - housing to endplate	8-069-506-00		1		1		1		1		1		1		1		1		1		1		1		1		1		1		1		1		1		1		1		
	Gasket - each end of brake	8-122-501-00		2		2		2		2		2		2		2		2		2		2		2		2		2		2		2		2		2		2		2		

* "-XX" brake suffix is -05 for 5/8" shaft. "-XX" brake suffix is -07 for 7/8" shaft.

TABLE 2
Components for Vertical Modifications
(no modifications required for 1.5 through 6 lb-ft brakes)

		Torque (lb-ft)	10				16											
		Current	AC		DC		AC		DC									
		Enclosure	O	E	O	E	O	E	O	E								
		Brake Model Number* →	1-055-741-XX		1-055-742-XX		1-055-745-XX		1-055-746-XX		1-055-751-XX		1-055-752-XX		1-055-755-XX		1-055-756-XX	
Item	Description	Part Number ↓	Obsolete															
Vertical Above Modification			Obsolete															
2A	Endplate assembly (with pins)		Obsolete															
3A	Stationary disc kit - vertical mounting	5-66-8352-00	2	2	2	2	2	2	2	2	2	2	2	2	2	2	2	
I	Vertical above mounting pin	9-32-4060-00	3	3	3	3	3	3	3	3	3	3	3	3	3	3	3	
J	Vertical mounting spring kit - blue	5-66-3151-00	1	1	1	1	1	1	1	1	1	1	1	1	1	1	1	
	Vertical mounting spring kit - white	5-66-3152-00	1	1	1	1	1	1	1	1	1	1	1	1	1	1	1	
Vertical Below Modification			Obsolete															
3B	Pressure plate kit - vertical mounting (w/o pins)	5-66-8553-00	1	1	1	1	1	1	1	1	1	1	1	1	1	1	1	
L	Vertical mounting pins	9-32-4070-00	3	3	3	3	3	3	3	3	3	3	3	3	3	3	3	
3A	Stationary disc kit - vertical mounting	5-66-8352-00	1	1	1	1	1	1	1	1	1	1	1	1	1	1	1	
J	Vertical mounting spring kit - blue	5-66-3151-00	1	1	1	1	1	1	1	1	1	1	1	1	1	1	1	
2B	Endplate assembly		Obsolete															

See 56,700 series brake for complete replacement.

Support Plate Assembly

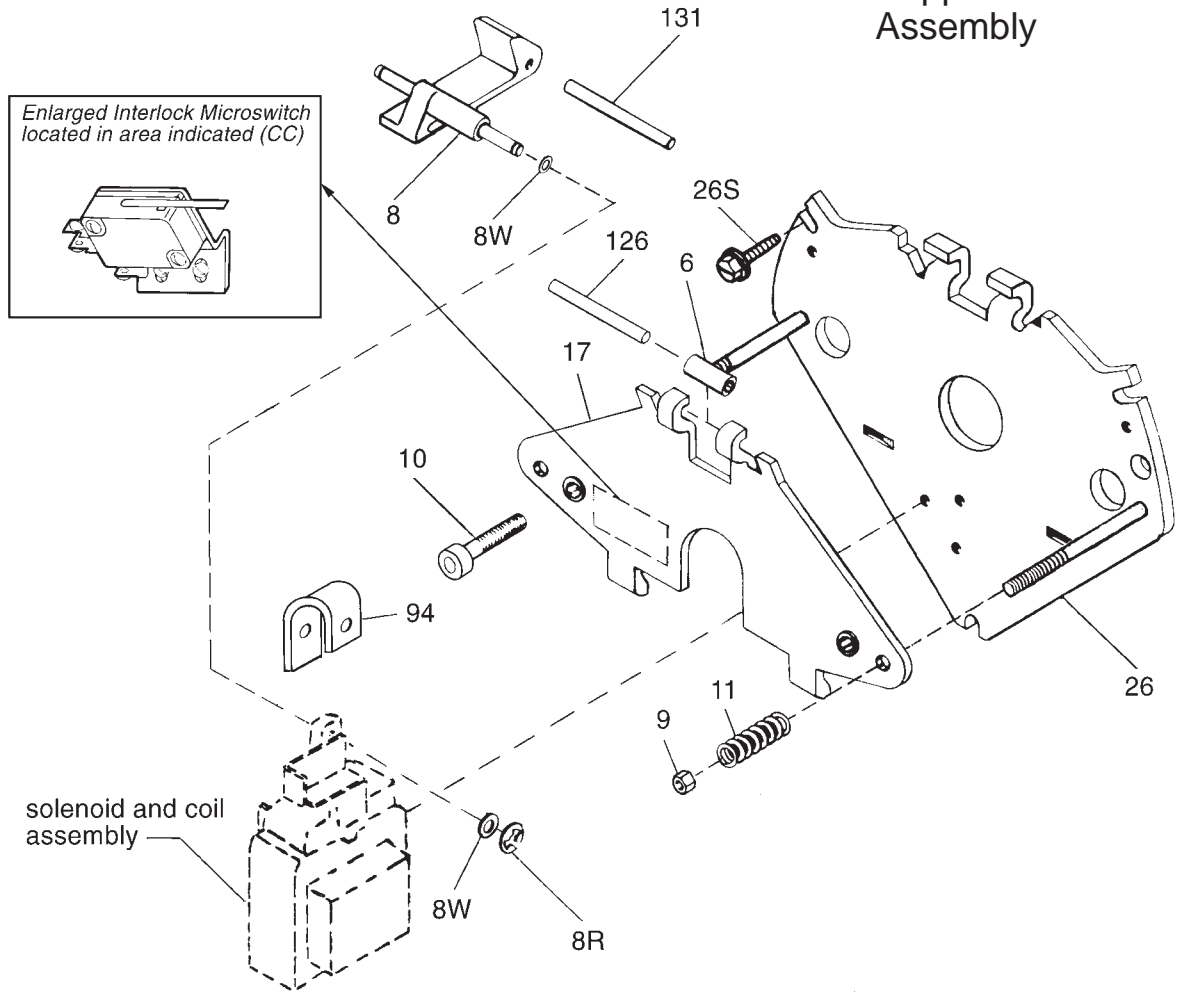

TABLE 3

Item	Description	Part Number	Torque (lb-ft)			
			1.5 & 3	6	10	15
*	Support plate assembly	5-42-5622-00-14	1			
*	Support plate assembly	5-42-5623-00-14		1		
*	Support plate assembly	5-42-5624-00-14			1	
*	Support plate assembly	5-42-5625-00-14				1
6 8 8R	Bearing Solenoid lever Retaining ring	Obsolete Replace entire support plate (Item numbers are for reference only)				
8W 9 10	Spacer Torque adjustment nut Wear adjustment screw					
11	Pressure spring Pressure spring Pressure spring					
17 126 94	Lever arm & stop nut assy. Bearing pin Plunger stop					
26	Support plate & spring stud assy. Support plate & spring stud assy.					
26S 131	Screw - thread roll 10-24 x 1/2" Pivot pin					

TABLE 5

Description	Part Number	Torque (lb-ft)				
		1.5 & 3	6	10	15	
No. 4 coil kit 60 Hz	115/230 Vac	5-66-6407-33	1			
	230/460 Vac	5-66-6409-33	1			
	115 Vac	5-66-6401-33	1			
	230 Vac	5-66-6402-33	1			
	460 Vac 575 Vac	5-66-6404-33 5-66-6405-33	1 1			
No. K4 coil kit 60 Hz	115/230 Vac	5-66-6457-33		1	1	
	230/460 Vac	5-66-6459-33		1	1	
	115 Vac	5-66-6451-33		1	1	
	230 Vac	5-66-6452-33		1	1	
	460 Vac 575 Vac	5-66-6454-33 5-66-6455-33		1 1	1 1	
No. K4+ coil kit 60 Hz	115/230 Vac	5-66-6407-23			1	
	230/460 Vac	5-66-6409-23			1	
	115 Vac	5-66-6401-23			1	
	230 Vac	5-66-6402-23			1	
	460 Vac 575 Vac	5-66-6404-23 5-66-6405-23			1 1	
CC	Interlock microswitch	5-57-5515-00	1	1	1	1
DC Brake Coils		Consult Factory				

*Support plate assembly includes all items shown above except coil. See Table 5.

See 56,700 series brake for complete replacement.

Solenoid and Coil Assembly

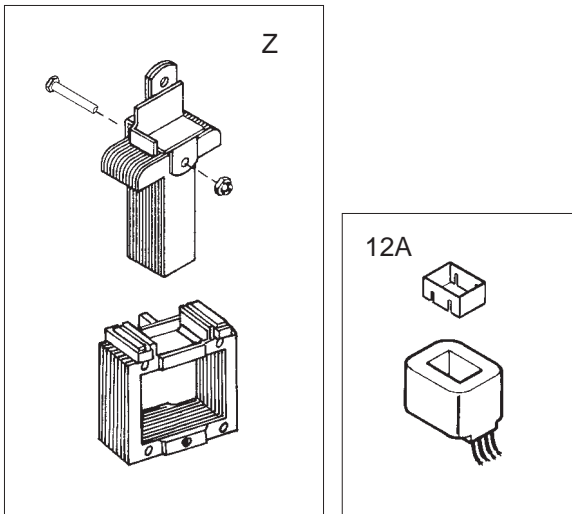

Manual Release Kits (for standard open brakes only)

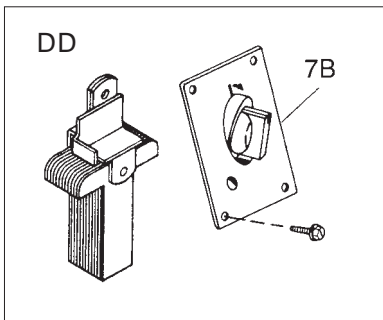

TABLE 4 - Contents of Kits and Assemblies
(contents may vary)

Letter Designation	Kit Description
3	Stationary disc kit (5-66-8351-00) 1 - Stationary disc
4	Friction disc kit (5-66-8452-00) Friction disc
3A	Stationary disc kit - vertical mounting (5-66-8352-00) 1 - Stationary disc for vertical above or below mounting
J	Vertical mounting spring kit - blue (5-66-3151-00) 3 - Vertical mounting springs - blue
	Vertical mounting spring kit - white (5-66-3152-00) 3 - Vertical mounting springs - white
3B	Pressure plate kit - vertical mounting (5-66-8553-00) 1 - Pressure plate - vertical below
Z	No. 4 solenoid kit (5-12-5547-00) 1 - Plunger 1 - Solenoid link 1 - Frame (including mounting bracket) 1 - Solenoid link cap screw 1 - Solenoid link nut 3 - Solenoid mounting screws
12A	Coil kit (5-66-64XX-33) Coil Top plunger guide Wire nuts } where Crimp terminals } required
CC	Interlock microswitch (5-57-5515-00) 1 - Microswitch 1 - Mounting bracket 4 - Screws 2 - Lock washers 2 - Star washers 2 - Nuts
Manual Release Kits	
DD	Obsolete