

# Parts List for 87,300-01 & -02 Series Brakes

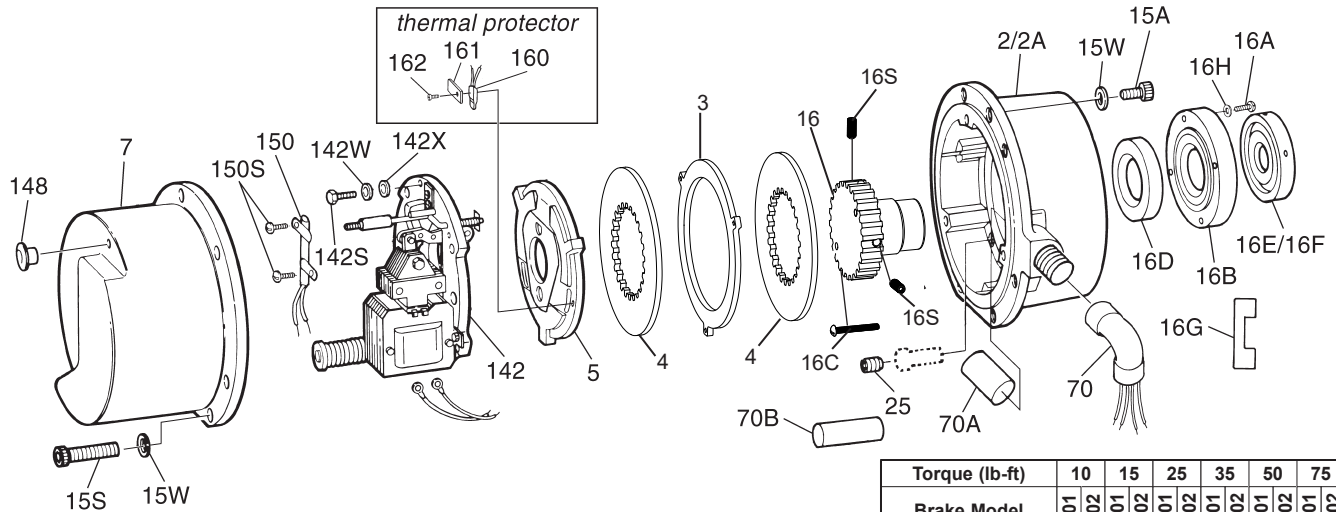

### Information required when ordering replacement parts:

- Give part number of parts or kits needed, brake model number, and brake serial number. The brake model and serial number may identify special brakes not covered by this parts list.
- When ordering hubs, specify shaft diameter (hub bore) and keyway. Standard hub shape changed from square to splined. Reference P/N 8-178-000-38 for hub and disc cross reference.

For installation and service instructions, see P/N 8-078-927-05. Detailed service instruction sheet is included with each kit.

**TABLE 1 - Components of Standard Brake & Components for Vertical Components**

Item	Description	Part Number ↓	Torque (lb-ft)									
			10	15	25	35	50	75	105			
			<b>Brake Model Number →</b> 1-087-311-01    1-087-311-02    1-087-321-01    1-087-321-02    1-087-331-01    1-087-331-02    1-087-341-01    1-087-341-02    1-087-351-01    1-087-351-02    1-087-361-01    1-087-361-02    1-087-381-01    1-087-381-02									
16E	Slinger	8-103-708-01	1	1	1	1	1	1	1	1	1	1
16F	Slinger set screw	9-22-0804-00	2	2	2	2	2	2	2	2	2	2
16G	Slinger positioning template	8-141-714-00	1	1	1	1	1	1	1	1	1	1
2	Endplate assembly	5-50-7041-00-30*	1	1	1	1	1	1	1	1	1	1
<i>consult factory</i>	Endplate assembly	5-50-7042-00-30*						1	1			
	Endplate assembly	5-50-7043-00-30*										1
3	Stationary disc kit (hor. or vert.)	5-66-8372-00								1	1	2
4	Friction disc	5-66-8488-00	1	1	1	1	1	2	2	2	3	3
5	Pressure plate	8-005-702-06	1	1	1	1	1	1	1	1	1	1
7	Housing	8-007-739-11	1	1	1	1	1	1	1	1	1	1
15A	Cap screw - housing removal	9-17-3210-00	1	1	1	1	1	1	1	1	1	1
15S	Cap screw - housing	9-17-3224-00	7	7	7	7	7	7	7	7	7	7
15W	Lock washer	9-45-1332-00	8	8	8	8	8	8	8	8	8	8
16	Hub and set screw assembly	5-16-7132-00	1	1	1	1	1	1	1	1	1	1
	Hub and set screw assembly	5-16-7133-00										1
16C	Screw - hub positioning	9-10-3032-00	1	1	1	1	1	1	1	1	1	1
25	Pipe plug	9-33-0184-00	4	4	4	4	4	4	4	4	4	4
70B	Fiberglass tubing	8-101-114-07	1	1	1	1	1	1	1	1	1	1
142**	Support plate assembly	5-42-7301-00	1									
	Support plate assembly	5-42-7303-00		1								
	Support plate assembly	5-42-7305-00				1		1				
	Support plate assembly	5-42-7307-00					1			1	1	
142S	Screw - support plate	9-16-3014-01	3	3	3	3	3	3	3	3	3	3
142W	Conical spring washer	9-46-0006-00	3	3	3	3	3	3	3	3	3	3
142X	Flat washer, 1/4 I.D. x 9/16 O.D.	9-46-0005-00	3	3	3	3	3	3	3	3	3	3
148	Release knob	8-148-703-00	1	1	1	1	1	1	1	1	1	1
150	Space heater 115 V (optional)	9-62-2054-00	1	1	1	1	1	1	1	1	1	1
150S	Screw - space heater	9-25-7321-00	2	2	2	2	2	2	2	2	2	2
160	Thermal protector (TSW2)	9-62-8017-00	1	1	1	1	1	1	1	1	1	1
161	Lock plate	8-076-713-00	1	1	1	1	1	1	1	1	1	1
162	Screw - lock plate	9-14-2704-00	1	1	1	1	1	1	1	1	1	1
<b>Vertical Above Modification - must also order Item 3 (above) for stationary disc, horizontal or vertical, kit</b>												
2B	Endplate assembly (includes union, lead wires with fiberglass tubing, and vertical above pins)	5-50-7044-00 5-50-7045-00 5-50-7046-00	1	1	1	1	1	1	1	1	1	1
I	Vertical above spring & spacer kit	5-66-3171-00	1	1	1	1	1	1	1	1	1	1
5A	Pressure plate	8-005-702-07	1	1	1	1	1	1	1	1	1	1
H	Vertical above pin	8-061-711-00	3	3	3	3						
	Vertical above pin	8-061-712-00							3	3		
	Vertical above pin	8-061-713-00									3	3
<b>Vertical Below Modification - must also order Item 3 (above) for stationary disc, horizontal or vertical, kit</b>												
5B	Pressure plate - less pins (Item J)	8-005-702-08								1	1	1
J	Vertical mounting pin	8-061-715-00								3	3	
	Vertical mounting pin	8-061-716-00										3
K	Vertical below spring kit - green	5-66-3172-00								1	1	
	Vertical below spring kit - red	5-66-3173-00										1

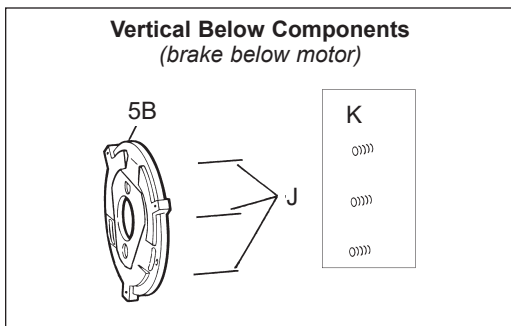
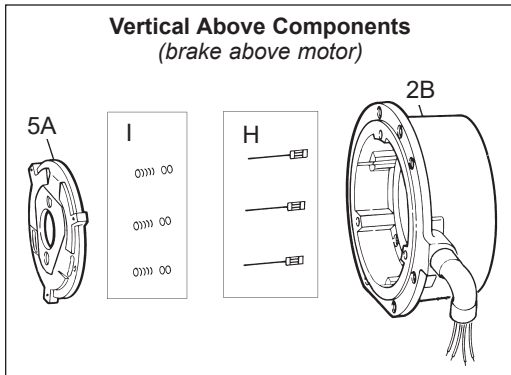

\* Indicate leadwire position B or C

## Support Plate Assembly

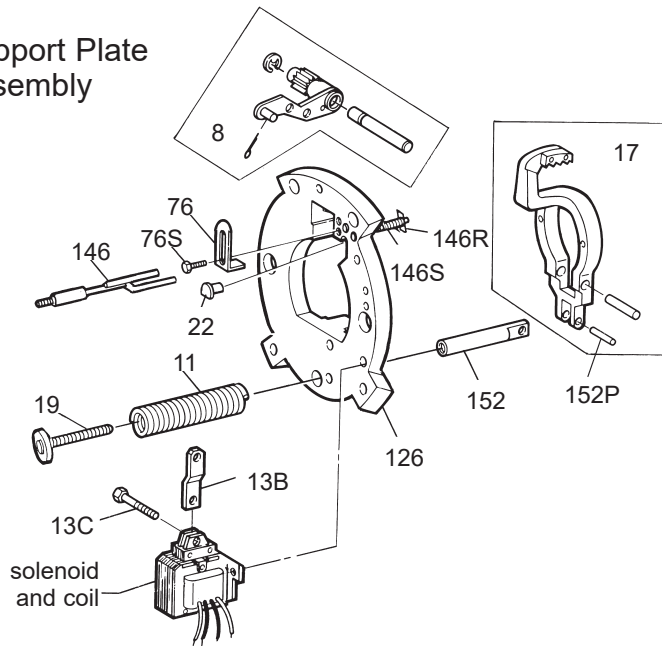

**TABLE 2 - Components of Support Plate 5-42-730X-00 Assembly**

Item	Description	Part Number	Torque (lb-ft)			
			10	15	25 & 50	35, 75 & 105
126	Support plate and bearing assembly Support plate and bearing assembly	5-26-7007-00 5-26-7008-00	1	1	1	1
8	Solenoid lever and pinion kit	5-66-7371-00	1	1	1	1
17	Lever arm kit	5-66-7271-00	1	1	1	1
19	Pressure spring tube kit	5-66-7471-00	1	1	1	1
11	Pressure spring kit - black (formerly blue) Pressure spring kit - white (formerly yellow) Pressure spring kit - orange (formerly red) Pressure spring kit - purple (formerly green)	5-66-3072-00 5-66-3074-00 5-66-3076-00 5-66-3078-00	1	1	1	1
U	No. 5 AC solenoid kit No. 6 AC solenoid kit No. 8 AC solenoid kit	5-66-5051-00 5-66-5061-00 5-66-5081-00	1	1	1	1
13B	Solenoid link Solenoid link	8-013-703-00 8-013-704-00	1	1	1	1
13C	Solenoid link cap screw Solenoid link cap screw Solenoid link cap screw	8-157-701-00 8-157-702-00 8-157-703-00	1	1	1	1
22	Solenoid lever stop	8-022-203-00	1	1	1	1
76	Wrap spring stop	8-076-703-00	1	1	1	1
76S	Screw - stop	9-25-7331-00	2	2	2	2
146	Release rod	5-28-7015-00	1	1	1	1
146R	Spring retainer	8-076-706-00	1	1	1	1
146S	Release spring	9-70-1525-00	1	1	1	1

**TABLE 3 - Coil Assembly**

Item	Description	Part Number	Torque (lb-ft)				
			10	15	25 & 50	35, 75 & 105	
V	No. 5 Coil Kit 60 Hz	230/460 Vac	5-96-6509-05	1			
		115 Vac	5-96-6501-05	1			
		230 Vac	5-96-6502-05	1			
		460 Vac	5-96-6504-05	1			
		575 Vac	5-96-6505-05	1			
	No. 6 Coil Kit 60 Hz	230/460 Vac	5-96-6609-05		1	1	
		115 Vac	5-96-6601-05		1	1	
		230 Vac	5-96-6602-05		1	1	
		460 Vac	5-96-6604-05		1	1	
		575 Vac	5-96-6605-05		1	1	
	No. 8 Coil Kit 60 Hz	230/460 Vac	5-96-6809-05				1
		115 Vac	5-96-6801-05				1
		230 Vac	5-96-6802-05				1
		460 Vac	5-96-6804-05				1
		575 Vac	5-96-6805-05				1

## Solenoid & Coil Assemblies

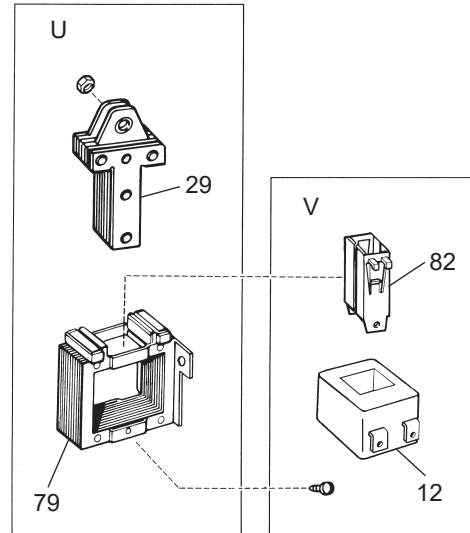

**TABLE 4 - Contents of Kits & Assemblies (contents may vary)**

Item Designation	Kit Description
3	Stationary disc kit (5-66-8372-00) 1 - Stationary disc (horizontal or vertical)
4	Friction disc kit (5-66-8488-00) 1 - Friction disc
I	Vertical above spring and spacer kit (5-66-3171-00) 9 - Vertical above mounting springs 9 - Vertical above spring spacers
K	Vertical below spring kit - green (5-66-3172-00) 3 - Vertical below springs - green  Vertical below spring kit - red (5-66-3173-00) 3 - Vertical below springs - red
8	Solenoid lever and pinion kit (5-66-7371-00) 1 - Solenoid lever and pinion assembly 1 - Cotter pin 1 - Solenoid lever pivot pin 1 - Pivot pin retaining ring
17	Lever arm kit (5-66-7271-00) 1 - Lever arm assembly 1 - Lever arm pivot pin 1 - Spring tube pivot pin
19	Pressure spring tube kit (5-66-7471-00) 1 - Pressure spring tube 1 - Pressure spring screw 1 - Spring tube pivot pin
11	Pressure spring kit (5-66-307X-00) 1 - Pressure spring
U	AC solenoid kit (5-66-50X1-00) 1 - Plunger 1 - Frame 3 - Solenoid mounting screws 3 - Solenoid mounting conical spring washers 1 - Solenoid link nut
V	Coil assembly (5-96-6XXX-05) AC 1 - Coil 2 - Plunger guides 2 - Plunger guide screws