

Parts List for 87,700-B Series Washdown Brakes

Information required when ordering replacement parts:

- Give part number of parts or kits needed, brake model number, and brake serial number. The brake model and serial number may identify special brakes not covered by this parts list.
- When ordering hubs, specify shaft diameter (hub bore) and keyway.
- Consult factory if white epoxy paint finish required on housing or endplate.
- SA-839 washdown brake gasket and plug installation sheet included with each brake.

For installation and service instructions, see Sheet 8-078-927-07. *Detailed service instruction sheet is included with each kit.*

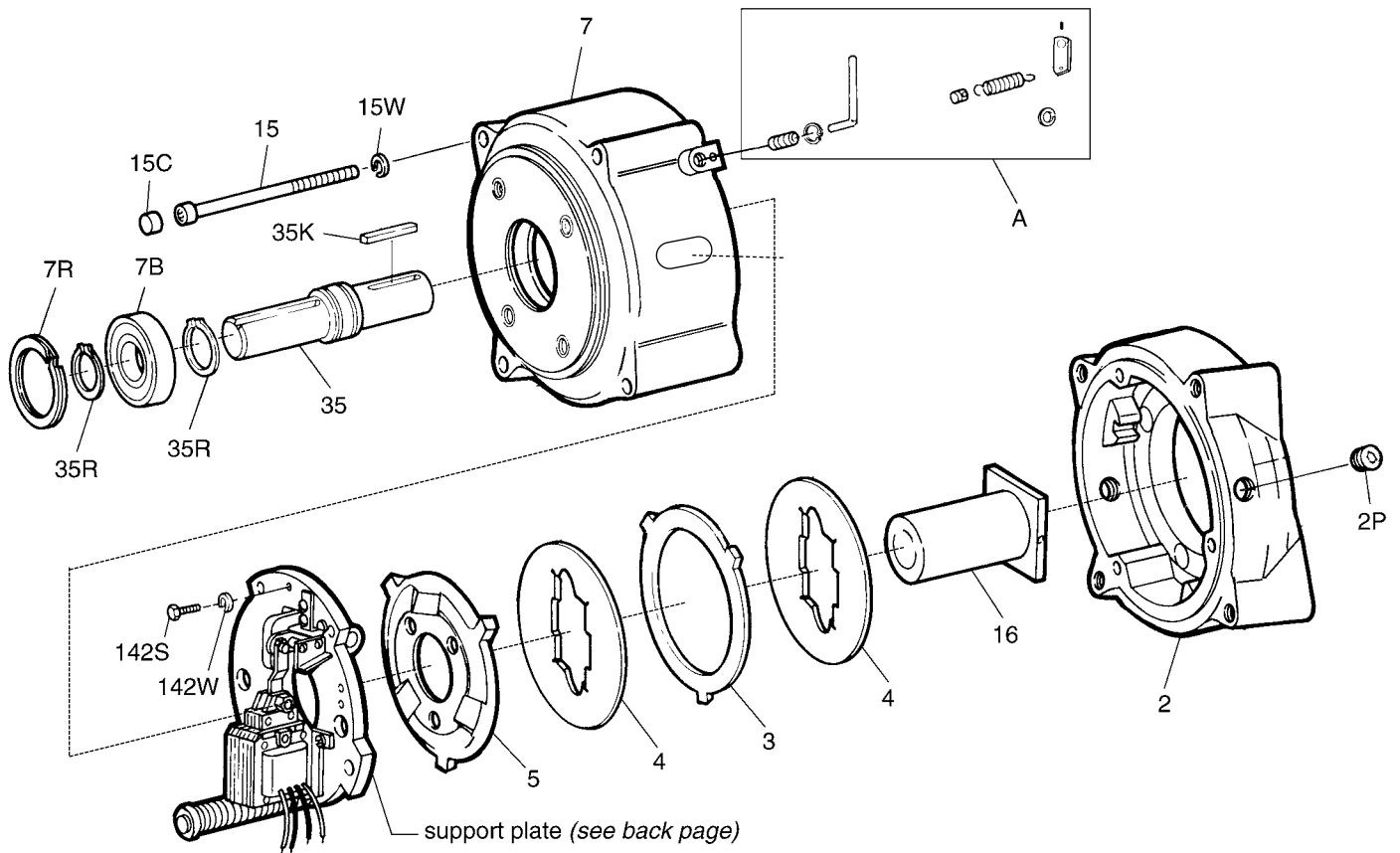

Vertical Above Components (brake above motor)

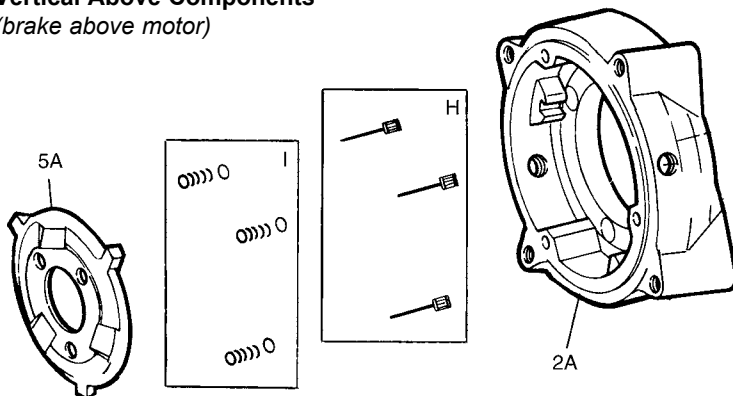

Vertical Below Components (brake below motor)

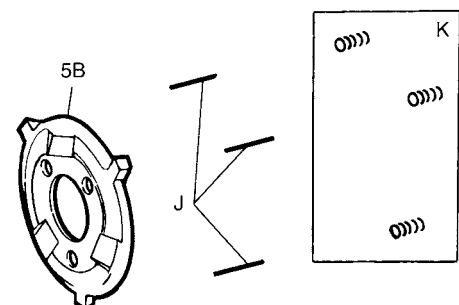

TABLE 1
Components of AC Brake

Item	Description	Part Number	Brake Model Number			1-087-7XX-B1* 1-1/8" Shaft			1-087-7XX-B3* 1-3/8" Shaft			1-087-7XX-B5* 1-5/8" Shaft		
			Torque (lb-ft)	10 thru 35	50 and 75	105	10 thru 35	50 and 75	105	10 thru 35	50 and 75	105		
7R	Retaining ring (housing)	9-03-0076-00	1	1	1									
	Retaining ring (housing)	9-03-0126-00				1	1	1	1	1	1			
35R	Retaining ring (shaft)	9-03-0132-00	2	2	2									
	Retaining ring (shaft)	9-03-0133-00				2	2	2	2	2	2			
7B	Ball bearing	9-01-0506-00	1	1	1									
	Ball bearing	9-01-0509-00				1	1	1	1	1	1			
35	Brake shaft	8-035-709-00	1	1	1									
	Brake shaft	8-035-710-00				1	1	1						
	Brake shaft	8-035-711-00							1	1	1			
35K	Key	9-50-1030-00	1	1	1									
	Key	9-50-1230-00				1	1	1						
	Key	9-50-1430-00							1	1	1			
7	Housing & manual release assembly 1 1/8" shaft	10, 15, 25 & 50 lb-ft 35, 75 & 105 lb-ft	5-07-7033-03	1	1									
			5-07-7033-00	1	1	1								
	Housing & manual release assembly 1 3/8" & 1 5/8" shaft	10, 15, 25 & 50 lb-ft 35, 75 & 105 lb-ft	5-07-7034-03				1	1		1	1			
			5-07-7034-00				1	1	1	1	1	1	1	
A	Manual release kit (part of Item 8)		5-55-7002-00	1	1	1	1	1	1	1	1	1	1	
15	Housing cap screw		9-16-3486-00	4	4	4	4	4	4	4	4	4	4	
15W	Lock washer spring medium 1/2		9-45-0334-00	4	4	4	4	4	4	4	4	4	4	
15C	Cap		9-67-0002-00	4	4	4	4	4	4	4	4	4	4	
not shown	Pipe plug (drain) 1/8"		9-33-0325-01	1	1	1	1	1	1	1	1	1	1	
5	Pressure plate		8-005-708-01	1	1	1	1	1	1	1	1	1	1	
4	Friction disc kit - standard		5-66-8472-00	1	2	3	1	2	3	1	2	3		
3	Stationary disc kit		5-66-8372-00	0	1	2	0	1	2	0	1	2		
16	Hub and set screw assembly		5-16-7110-00	1			1			1				
	Hub and set screw assembly		5-16-7111-00		1			1			1			
	Hub and set screw assembly		5-16-7112-00			1			1			1		
2	Endplate		8-002-788-03	1			1			1				
	Endplate		8-002-789-03		1			1			1			
	Endplate		8-002-790-03			1			1			1		
142S	Machine screw 1/4 - 20 x 7/8" filister head		9-12-3014-00	3	3	3	3	3	3	3	3	3	3	
142W	Lock washer 1/4" high collar - spring		9-45-1330-00	3	3	3	3	3	3	3	3	3	3	
not shown	"O" ring gasket (housing-to-endplate)		8-073-002-04	1	1	1	1	1	1	1	1	1	1	
	"O" ring gasket (each end of brake)		8-073-002-03	2	2	2	2	2	2	2	2	2	2	
not shown	Pipe plug (external lead holes) 1/2"		9-33-0624-00	1	1	1	1	1	1	1	1	1	1	
Vertical Above Modification - for stationary disc(s) see Item E														
5A	Pressure plate		8-005-708-02	1	1	1	1	1	1	1	1	1	1	
2A	Endplate (with pins Item H)		5-20-7074-00	1			1			1				
	Endplate (with pins Item H)		5-20-7075-00		1			1			1			
	Endplate (with pins Item H)		5-20-7076-00			1			1			1		
H	Vertical above mounting pin kit (1-disc brake)		5-66-3371-00	1			1			1				
	Vertical above mounting pin kit (2-disc brake)		5-66-3372-00		1			1			1			
	Vertical above mounting pin kit (3-disc brake)		5-66-3373-00			1			1			1		
I	Vertical above spring and spacer kit		5-66-3171-00	1	1	1	1	1	1	1	1	1	1	
Vertical Below Modification - for stationary disc(s) see Item E														
5B	Pressure plate (less pins Item J)		8-005-708-03		1	1		1	1		1	1		
J	Vertical mounting pin		8-061-715-00		3			3			3			
	Vertical mounting pin		8-061-716-00			3			3			3		
K	Vertical below spring kit - green		5-66-3172-00		1	1		1	1		1	1		
	Vertical below spring kit - red		5-66-3173-00			1			1			1		

* "X" in brake model number denotes variables in torque rating, enclosure and current. i.e. 1-087-7XX-B1

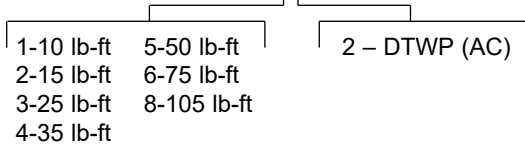

TABLE 2: Components of Support Plate (also see Table 4)*						
Item	Description	Part Number	Torque (lb-ft)			
			10	15	25 50	35 75 105
126	Support plate and bearing assembly	5-26-7006-00	1	1	1	1
22	Solenoid lever stop	8-022-203-00	1	1	1	1
76	Wrap spring stop	8-076-703-00	1	1	1	1
76S	Screw (wrap spring stop) 10-24 x 1/2	9-25-7331-00	2	2	2	2
79P	Spacer (solenoid)	8-179-701-00	1	1	1	0
8	Solenoid lever and pinion kit	5-96-7371-00	1	1	1	1
170	Release plate	8-170-706-00	1	1	1	1
170N	Nut (release plate) 1/4 x 20	9-40-3730-00	2	2	2	2
170S	Cap screw (release plate)	9-15-1031-00	2	2	2	2
171	Spacer (release plate)	8-141-707-00	2	2	2	2
17	Lever arm assembly	5-17-7005-00	1	1	1	1
130	Pivot pin (lever arm)	9-32-3111-00	1	1	1	1
152P	Pivot pin (spring tube)	9-32-4059-00	1	1	1	1
130B	Bearing (washer type)	8-138-701-00	2	2	2	2
152	Pressure spring tube kit	5-66-7471-00	1	1	1	1
11	Pressure spring kit—black (formerly blue)	5-66-3072-00	1	1	1	1
	Pressure spring kit—white (formerly yellow)	5-66-3074-00				
	Pressure spring kit—orange (formerly red)	5-66-3076-00				
	Pressure spring kit—purple (formerly green)	5-66-3078-00				
AC Brakes						
U	No. 5 AC solenoid kit	5-66-5051-00	1	1	1	1
	No. 6 AC solenoid kit	5-66-5061-00				
	No. 8 AC solenoid kit	5-66-5082-00				
13B	Solenoid link	8-013-708-00	1	1	1	1
	Solenoid link	8-013-709-00				
13C	Solenoid link cap screw	8-157-701-00	1	1	1	1
	Solenoid link cap screw	8-157-702-00				
	Solenoid link cap screw	8-157-703-00				
V	Size 5 Strength 3 Coil kit 60 Hz	115/230 Vac	5-96-6509-25	1		
		230/460 Vac	5-96-6509-27	1		
		115 Vac	5-96-6509-20	1		
		230 Vac	5-96-6509-24	1		
	Size 6 Strength 3 Coil kit 60 Hz	460 Vac	5-96-6509-26	1		
		575 Vac	5-96-6509-29	1		
		115/230 Vac	5-96-6609-38		1	1
		230/460 Vac	5-96-6609-49		1	1
	Size 8 Strength 3 Coil kit 60 Hz	115 Vac	5-96-6609-30		1	1
		230 Vac	5-96-6609-37		1	1
		460 Vac	5-96-6609-47		1	1
		575 Vac	5-96-6609-51		1	1
Size 8 Strength 3 Coil kit 60 Hz	115/230 Vac	5-96-6809-59			1	
	230/460 Vac	5-96-6809-69			1	
	115 Vac	5-96-6809-52			1	
	230 Vac	5-96-6809-58			1	
XX**	Brake release interlock switch	5-57-5504-00	1	1	1	1
	Brake release interlock switch	5-57-5506-00				

* AC brakes with the brake release interlock (N.O.) switch Item XX use Item W solenoid assembly for switch mounting in place of Item U.

TABLE 3: Content of Kits and Assemblies (contents may vary)	
Letter	Kit Description
4	Friction disc kit – standard (5-66-8472-00) 1 – Friction disc
3	Stationary disc kit (5-66-8372-00) 1 – Stationary disc
H	Vertical above mounting pin kit (5-66-337X-00) 3 – Vertical above mounting pins
I	Vert. above spring & spacer kit (5-66-3171-00) 9 – Vertical above mounting springs 9 – Vertical above spring spacers
K	Vert. below spring kit – green (5-66-3172-00) 3 – Vertical below springs – green
	Vertical below spring kit – red (5-66-3173-00) 3 – Vertical below springs – red
8	Solenoid lever and pinion kit (5-96-7371-00) 1 – Solenoid lever and pinion assembly 1 – Cotter pin 1 – Solenoid lever pivot pin 1 – Pivot pin retaining ring
19 & 152	Pressure spring tube kit (5-66-7471-00) 1 – Pressure spring tube 1 – Pressure spring screw 1 – Spring tube pivot pin
11	Pressure spring kit (5-66-307X-00) 1 – Pressure spring
U	AC solenoid kit (5-66-50XX-00) 1 – Plunger 1 – Frame 3 – Solenoid mounting screws 3 – Solenoid mounting conical spring washers 1 – Solenoid link nut 1 – Drive loc pin (for #8 sol. only) (not shown) 1 – Washer (for #8 solenoid only) (not shown)
V	Coil kits (5-66-6X09-XX) AC coils 1 – Coil 2 – Plunger guides 2 – Plunger guide screws
XX	AC switch assy. (5-57-5504-00 or 5-57-5506-00) (brake release interlock switch – N.O.) 1 – AC switch 2 – Mounting screws 2 – Lock washers
Y	Arc suppression module (5-57-5711-00) 1 – Arc suppression module 1 – Cable strap
A	Manual release kit (5-55-7002-00) Spring anchor; Roll pin; Retaining ring Release spring; Bearing; Release lever Release arm; “O” ring

TABLE 4: Complete support plate assembly*	
	AC
6 lb-ft	5-42-7119-31-05
10 lb-ft	5-42-7121-31-05
15 lb-ft	5-42-7123-31-06
25/50 lb-ft	5-42-7125-31-06
35/75/105 lb-ft	5-42-7127-31-08

Support Plate Assembly

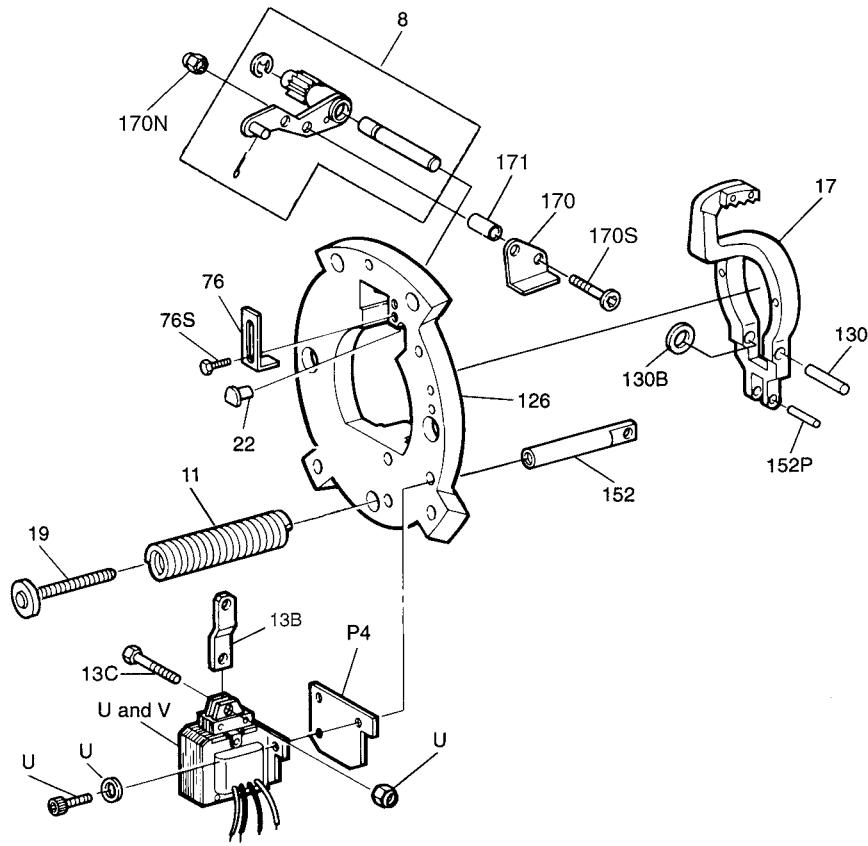

Solenoid and Coil

