

Parts List for 87,300-00 Series Brakes (UL Type 4)

Information required when ordering replacement parts:

- Give part number of parts or kits needed, brake model number, and brake serial number. The brake model and serial number may identify special brakes not covered by this parts list.
- When ordering hubs, specify shaft diameter (hub bore) and keyway. Standard hub shape changed from square to splined. Reference P/N 8-178-000-38 for hub and disc cross reference.

For installation and service instructions, see P/N 8-078-927-03.
Detailed service instruction sheet is included with each kit.

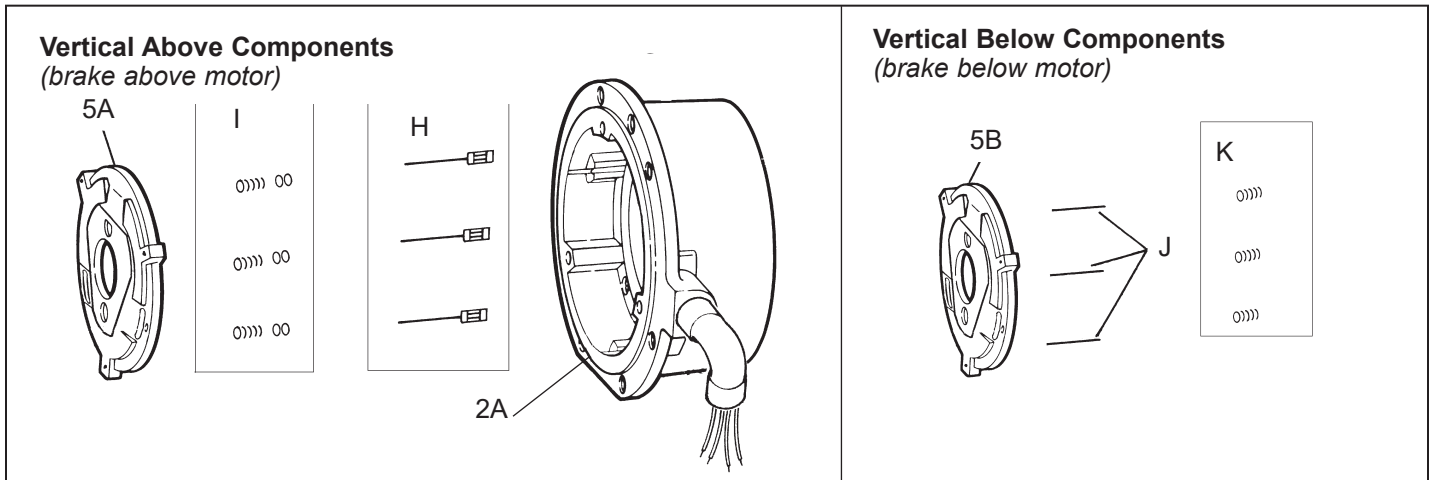
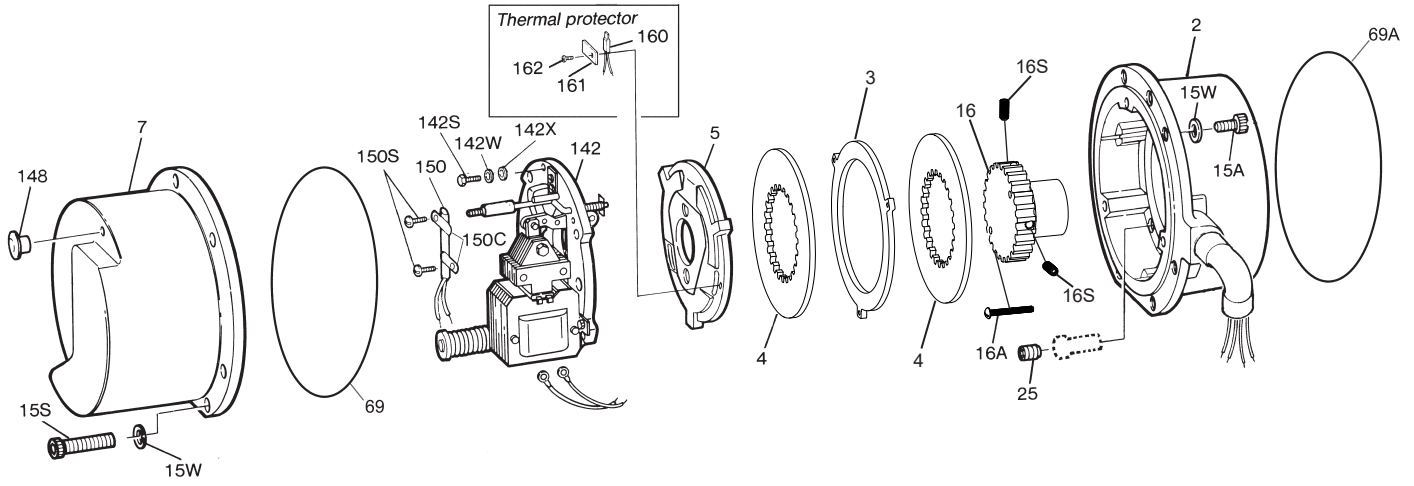

Item	Description	Part Number ↓	Style		Motor Mounted					
			Torque (lb-ft)	10	15	25	35	50	75	105
			Brake Model Number →	1-087-314-00	1-087-324-00	1-087-334-00	1-087-344-00	1-087-354-00	1-087-364-00	1-087-384-00
2 <i>consult factory</i>	Endplate assembly (includes union and lead wires with fiberglass tubing)	5-50-7031-00 5-50-7032-00 5-50-7033-00	1	1	1	1		1	1	
3	Stationary disc kit (horiz. or vert.)	5-66-8372-00					1	1	2	
4	Friction disc	5-66-8488-00	1	1	1	1	2	2	3	
5	Pressure plate	8-005-702-06	1	1	1	1	1	1	1	
7	Housing & seal assembly	5-07-7053-00	1	1	1	1	1	1	1	
15A	Cap screw – housing removal	9-17-3210-00	1	1	1	1	1	1	1	
15S	Cap screw – housing	9-17-3224-00	7	7	7	7	7	7	7	
15W	Lock washer	9-45-1332-00	8	8	8	8	8	8	8	
16	Hub and set screw assembly	5-16-7130-00	1	1	1	1	1	1		
	Hub and set screw assembly	5-16-7131-00							1	
16A	Screw-hub positioning	9-10-3032-00	1	1	1	1	1	1	1	
25	Pipe plug	9-33-0184-00	4	4	4	4	4	4	4	
69	O-ring (housing)	8-073-002-08	1	1	1	1	1	1	1	
69A	O-ring (endplate)	8-073-002-03	1	1	1	1	1	1	1	
150	Space heater 115v (optional)	9-62-2057-00	1	1	1	1	1	1	1	
	Space heater 230v (optional)	9-62-2060-00	1	1	1	1	1	1	1	
150C	Heater clamp	9-61-0077-00	2	2	2	2	2	2	2	
150S	Heater mounting screw	9-25-7322-00	2	2	2	2	2	2	2	

Item	Description	Part Number ↓	Torque (lb-ft)	10	15	25	35	50	75	105
			Brake Model Number →	1-087-314-00	1-087-324-00	1-087-334-00	1-087-344-00	1-087-354-00	1-087-364-00	1-087-384-00
			142*	Support plate assembly Support plate assembly Support plate assembly Support plate assembly	5-42-7301-00 5-42-7303-00 5-42-7305-00 5-42-7307-00		1		1	
142S	Screw - support plate	9-16-3014-00	3	3	3	3	3	3	3	3
142W	Conical spring washer	9-46-0006-00	3	3	3	3	3	3	3	3
142X	Flat washer, 1/4 I.D. x 9/16 O.D.	9-46-0005-00	3	3	3	3	3	3	3	3
148	Release knob	8-148-703-00	1	1	1	1	1	1	1	1
160	Thermal protector (TSW2)	9-62-8017-00	1	1	1	1	1	1	1	1
161	Lock plate	8-076-713-00	1	1	1	1	1	1	1	1
162	Screw - lock plate	9-14-2704-00	1	1	1	1	1	1	1	1
Vertical Above Modification**										
2A <i>consult factory</i>	Endplate assembly (includes union, lead wires with fiberglass tubing and vertical above pins)	5-50-7034-00 5-50-7035-00 5-50-7036-00		1	1	1	1		1	1
I	Vertical above spring and spacer kit	5-66-3171-00	1	1	1	1	1	1	1	1
5A	Pressure plate	8-005-702-07	1	1	1	1	1	1	1	1
H	Vertical above pin	8-061-711-00	3	3	3	3	3			
	Vertical above pin	8-061-712-00						3	3	
	Vertical above pin	8-061-712-00								3
Vertical Below Modification**										
5B	Pressure plate - less pins (Item J)	8-005-702-08						1	1	1
J	Vertical mounting pin	8-061-715-00						3	3	
	Vertical mounting pin	8-061-716-00								3
K	Vertical below spring kit - green	5-66-3172-00								
	Vertical below spring kit - red	5-66-3173-00						1	1	1

*Coil (kit V) is separate. **Must also order Item 3 (Table 1) for stationary disc, horizontal or vertical, kit.

Support Plate Assembly

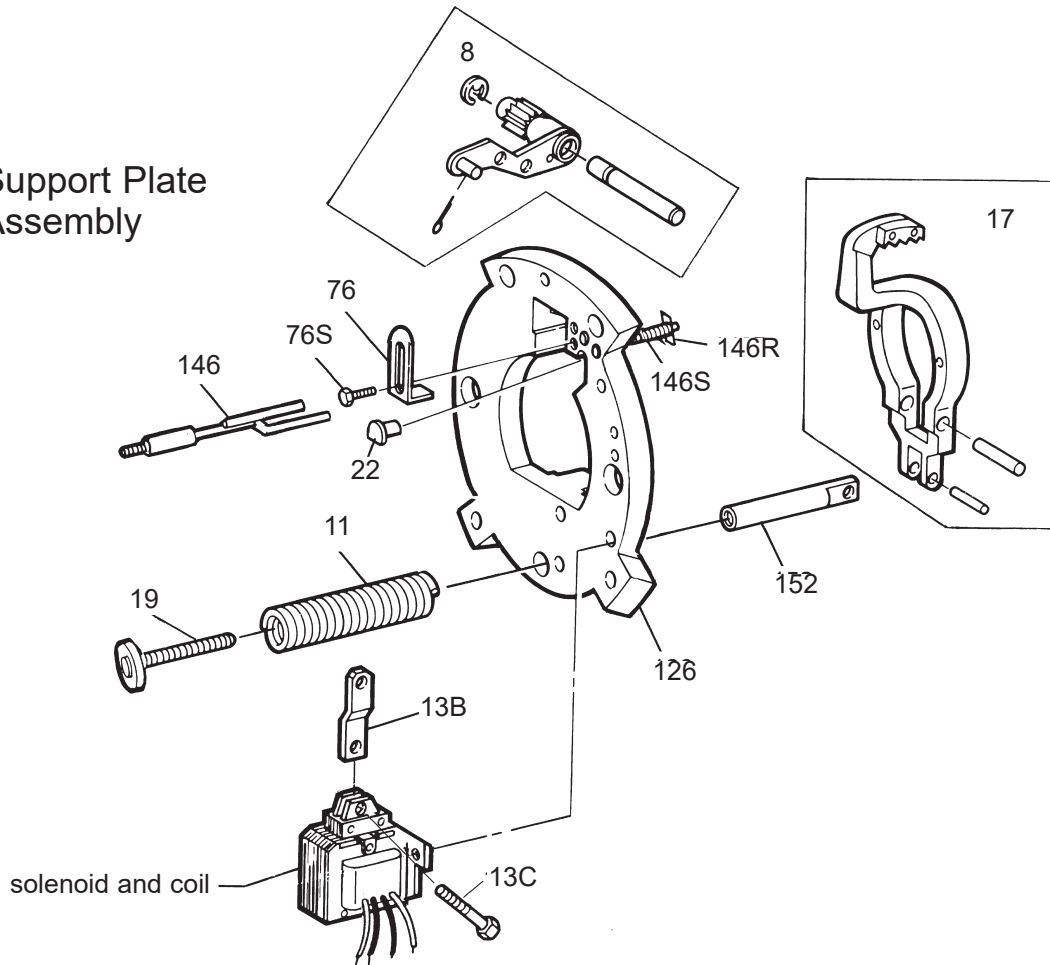

TABLE 3 - Components of Support Plate-5-42-730X-00

Item	Description	Part Number	Torque (lb-ft)			
			10	15	25 & 50	35, 75 & 105
126	Support plate and bearing assembly	5-26-7007-00	1	1	1	
	Support plate and bearing assembly	5-26-7008-00				1
8	Solenoid lever and pinion kit	5-66-7371-00	1	1	1	1
17	Lever arm kit	5-66-7271-00	1	1	1	1
19 & 152	Pressure spring tube kit	5-66-7471-00	1	1	1	1
11	Pressure spring kit-black (formerly blue)	5-66-3072-00	1			
	Pressure spring kit-white(formerly yellow)	5-66-3074-00		1		
	Pressure spring kit-orange (formerly red)	5-66-3076-00			1	
	Pressure spring kit-purple (formerly green)	5-66-3078-00				1
U	No. 5 AC solenoid kit	5-66-5051-00	1			
	No. 6 AC solenoid kit	5-66-5061-00		1	1	
	No. 8 AC solenoid kit	5-66-5081-00				1
13	Solenoid link	8-013-703-00	1	1	1	
	Solenoid link	8-013-704-00				1
13C	Solenoid link cap screw	8-157-701-00	1			
	Solenoid link cap screw	8-157-702-00		1	1	
	Solenoid link cap screw	8-157-703-00				1
22	Solenoid lever stop	8-022-203-00	1	1	1	1
76	Wrap spring stop	8-076-703-00	1	1	1	1
76S	Screw-stop	9-25-7331-00	2	2	2	2
146	Release rod	5-28-7015-00	1	1	1	1
146R	Spring retainer	8-076-706-00	1	1	1	1
146S	Release spring	9-70-1525-00	1	1	1	1

Solenoid & Coil Assembly

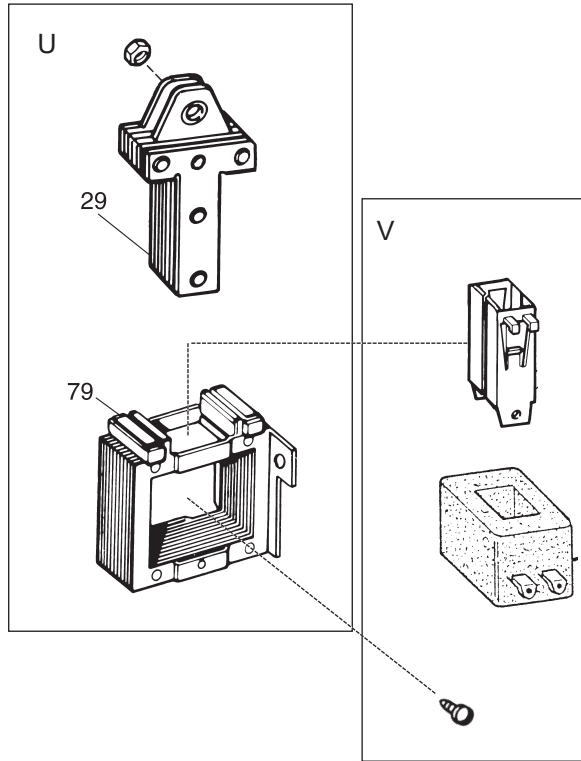

TABLE 4 - Coil Assembly

Item	Description	Part Number	Torque (lb-ft)			
			10	15	25 & 50	35, 75 & 105
V	230/460 Vac	5-96-6509-05	1			
	No.5 115 Vac	5-96-6501-05	1			
	Coil Kit 230 Vac	5-96-6502-05	1			
	60 Hz 460 Vac	5-96-6504-05	1			
	575 Vac	5-96-6505-05	1			
	230/460 Vac	5-96-6609-05		1	1	
	No.6 115 Vac	5-96-6601-05		1	1	
	Coil Kit 230 Vac	5-96-6602-05		1	1	
	60 Hz 460 Vac	5-96-6604-05		1	1	
	575 Vac	5-96-6605-05		1	1	
	230/460 Vac	5-96-6809-05				1
	No.8 115 Vac	5-96-6801-05				1
	Coil Kit 230 Vac	5-96-6802-05				1
	60 Hz 460 Vac	5-96-6804-05				1
	575 Vac	5-96-6805-05				1

TABLE 5 - Contents of Kits & Assemblies (contents may vary)

Item Designation	Kit Description	Item Designation	Kit Description
3	Stationary disc kit (5-66-8372-00) 1 – Stationary disc (horizontal or vertical)	17	Lever arm kit (5-66-7271-00) 1 – Lever arm assembly 1 – Lever arm pivot pin 1 – Spring tube pivot pin
4	Friction disc kit (5-66-8488-00) 1 – Friction disc	19 and 152	Pressure spring tube kit (5-66-7471-00) 1 – Pressure spring tube 1 – Pressure spring screw 1 – Spring tube pivot pin
I	Vertical above spring and spacer kit (5-66-3171-00) 9 – Vertical above mounting springs 9 – Vertical above spring spacers	11	Pressure spring kit (5-66-307X-00) 1-Pressure spring
K	Vertical below spring kit-green (5-66-3172-00) 3 – Vertical below springs-green	U	AC solenoid kit (5-66-50X1-00) 1 – Plunger 1 – Frame 3 – Solenoid mounting screws 3 – Solenoid mtg. conical spring washers 1 – Solenoid link nut
8	Vertical below spring kit-red (5-66-3173-00) 3 – Vertical below springs-red	V	Coil assembly (5-96-6XXX-05) AC 1 – Coil 2 – Plunger guides 2 – Plunger guide screws
	Solenoid lever and pinion kit (5-66-7371-00) 1 – Solenoid lever and pinion assembly 1 – Cotter pin 1 – Solenoid lever pivot pin 1 – Pivot pin retaining ring		