

Parts List for 87,700 Series Brakes (rev. D)

Information required when ordering replacement parts:

- Give part number of parts or kits needed, brake model number, and brake serial number. The brake model and serial number may identify special brakes not covered by this parts list.
 - Description items in **CAPITALIZED BOLD ITALICS** are recommended spare parts. One set per 5 brakes in service is recommended.
 - Enclosures are designated as follows:
O = Standard **E** = Dust-tight, waterproof (DTWP)
 - Housing and manual release assembly (Item B) includes manual release kit (Item BA).
- For installation and service instructions, see Sheet 8-078-927-07. Detailed service instruction sheet is included with each kit.

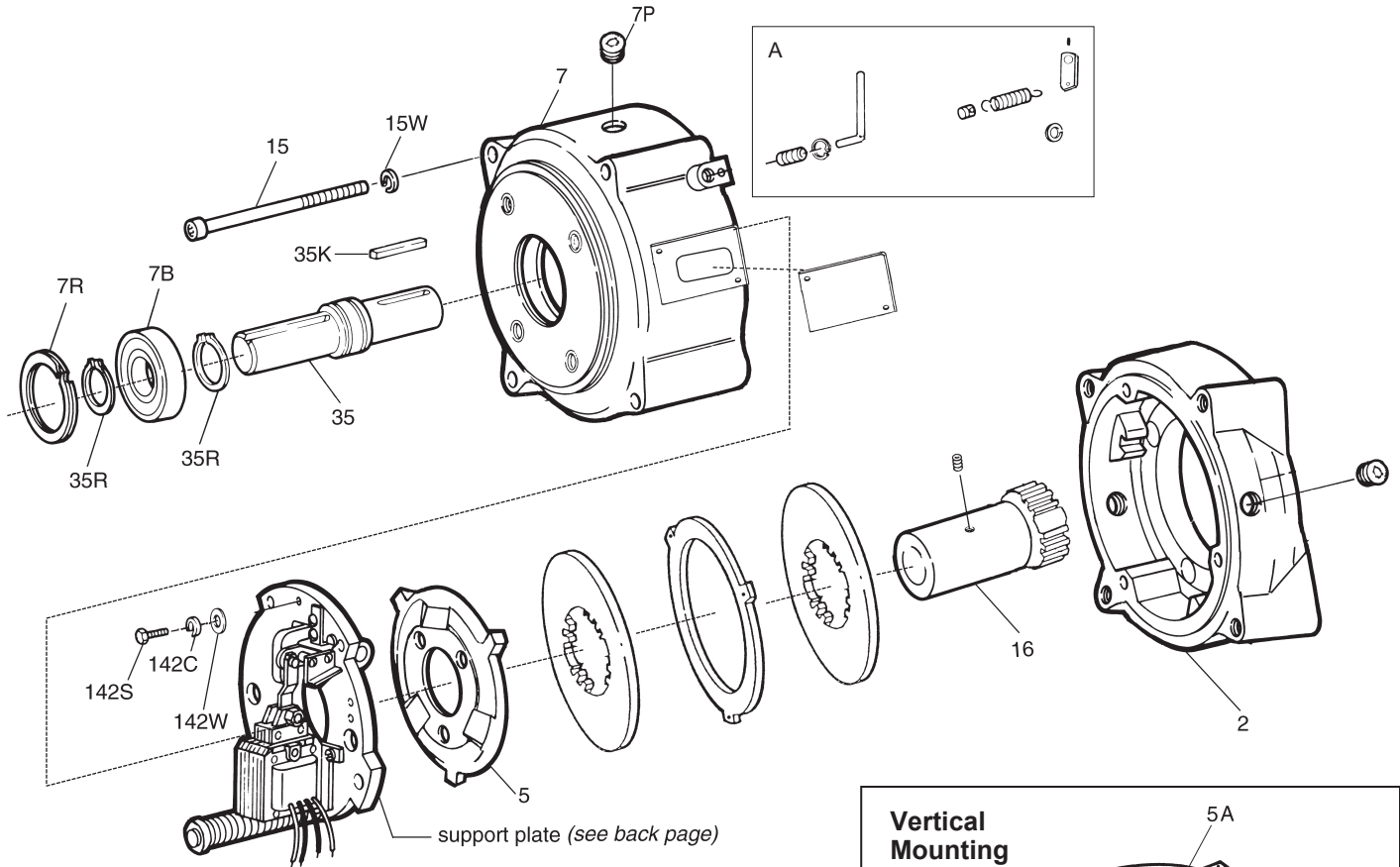

Stearns®

SEE INSTALLATION AND SERVICE SHEET OR INSTALLATION LABEL INSIDE OF HOUSING BEFORE INSTALLING, OPERATING OR SERVICING BRAKE.

Model number: 108775203QB
 Torque lb-ft: _____
 Volts: _____

Rev. D
 Serial number: _____
 Mounting: _____
 Hertz: _____

Amps inrush: _____
 Amps holding: _____

Reynold Industries, LLC, Stearns Division
 Cudahy, WI 53110, (414) 272-1100

LR 6254

Note:
MODEL NUMBER
 will appear on brake
 nameplate.

REVISION CONTROL
 (if applicable) and
 brake serial number

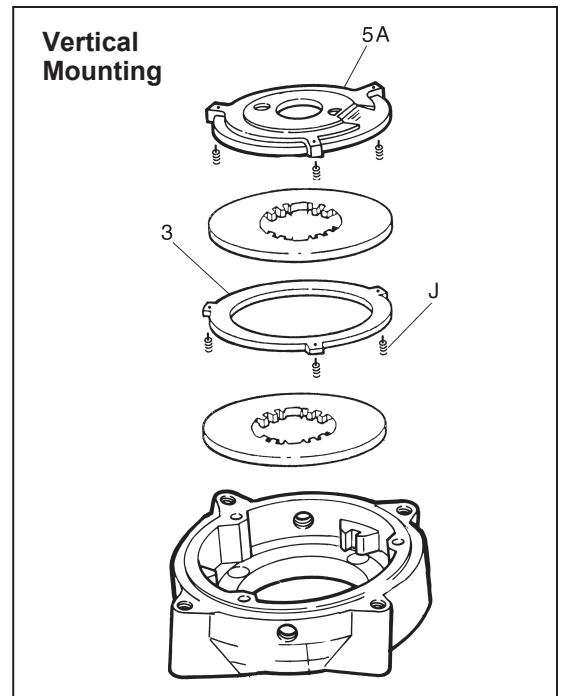

TABLE 1 Components of AC and DC Brake			Brake Model Number→		1-087-7XX-01* 1-1/8" Shaft						1-087-7XX-03* 1-3/8" Shaft						1-087-7XX-05* 1-5/8" Shaft					
			Torque (lb-ft)→		6 thru 35		50 and 75		105		6 thru 35		50 and 75		105		6 thru 35		50 and 75		105	
			Enclosure→		O	E	O	E	O	E	O	E	O	E	O	E	O	E	O	E	O	E
Item	Description		Part Number ↓																			
7R	Retaining ring (housing)		9-03-0126-00		1	1	1	1	1	1	1	1	1	1	1	1	1	1	1	1		
35R	Retaining ring (shaft)		9-03-0133-00		2	2	2	2	2	2	2	2	2	2	2	2	2	2	2	2		
7B	Ball bearing		9-01-0509-00		1	1	1	1	1	1	1	1	1	1	1	1	1	1	1	1		
35	Brake shaft Brake shaft Brake shaft		8-035-800-00 8-035-710-00 8-035-711-00		1	1	1	1	1	1	1	1	1	1	1	1	1	1	1	1		
35K	Key Key Key		9-50-1030-00 9-50-1230-00 9-50-1428-00		1	1	1	1	1	1	1	1	1	1	1	1	1	1	1	1		
7	Housing and manual release assembly	Including item 7P	5-07-7034-00		1	1	1	1	1	1	1	1	1	1	1	1	1	1	1	1		
7P	Access plug		9-33-0114-00		1	1	1	1	1	1	1	1	1	1	1	1	1	1	1	1		
A	Manual release kit		5-55-7002-00		1	1	1	1	1	1	1	1	1	1	1	1	1	1	1	1		
15	Housing cap screw		9-16-3486-00		4	4	4	4	4	4	4	4	4	4	4	4	4	4	4	4		
15W	Lock washer spring medium 1/2		9-45-0334-00		4	4	4	4	4	4	4	4	4	4	4	4	4	4	4	4		
not shown	Pipe plug (drain)		9-33-0325-00			1		1		1		1		1		1		1		1		
5	PRESSURE PLATE		8-005-708-01		1	1	1	1	1	1	1	1	1	1	1	1	1	1	1	1		
4	FRICTION DISC KIT - SPLINED		5-66-8483-00		1	0	2	2	3	3	1	1	2	2	3	3	1	1	2	2	3	3
3	STATIONARY DISC KIT		5-66-8372-00		0	0	1	1	2	2	0	0	1	1	2	2	0	0	1	1	2	2
16	Hub and set screw assembly Hub and set screw assembly Hub and set screw assembly Hub and set screw assembly Hub and set screw assembly Hub and set screw assembly Hub and set screw assembly Hub and set screw assembly Hub and set screw assembly		5-16-7210-00-01E 5-16-7210-00-01G 5-16-7210-00-01H 5-16-7211-00-01E 5-16-7211-00-01G 5-16-7211-00-01H 5-16-7212-00-01E 5-16-7212-00-01G 5-16-7212-00-01H		1	1					1	1					1	1			1	1
2	Endplate Endplate Endplate		8-002-788-22 8-002-789-22 8-002-790-22		1	1	1	1	1	1	1	1	1	1	1	1	1	1	1	1	1	
142S	Machine screw 1/4 - 20 x 7/8" hex head		9-16-3014-01		3	3	3	3	3	3	3	3	3	3	3	3	3	3	3	3		
142C	Conical spring washer, 1/4		9-46-0006-00		3	3	3	3	3	3	3	3	3	3	3	3	3	3	3	3		
142W	Flat washer 1/4 I.D. x 9/16 O.D.		9-46-0005-00		3	3	3	3	3	3	3	3	3	3	3	3	3	3	3	3		
not shown	"O" ring gasket (housing-to-endplate)		8-073-002-04			1		1		1		1		1		1		1		1		
not shown	"O" ring gasket (each end of brake)		8-073-002-03			2		2		2		2		2		2		2		2		
2P	Pipe plug (external lead holes)		9-33-0914-00		1	1	1	1	1	1	1	1	1	1	1	1	1	1	1	1		
Vertical Modification - for stationary disc(s) see Item 3 Table 1																						
5A	PRESSURE PLATE		8-005-708-12		1	1	1	1	1	1	1	1	1	1	1	1	1	1	1	1		
J	VERTICAL SPRING KIT (STANDARD)		5-66-3176-00		1	1	1	1	1	1	1	1	1	1	1	1	1	1	1	1		
	VERTICAL SPRING KIT (BRASS)		5-66-3177-00		1	1	1	1	1	1	1	1	1	1	1	1	1	1	1	1		

* "X" in brake model number denotes variables in torque rating, enclosure and current. i.e. 1-087-7XX-01

0-6 lb-ft	4-35 lb-ft	1 - standard (AC)
1-10 lb-ft	5-50 lb-ft	2 - DTWP (AC)
2-15 lb-ft	6-75 lb-ft	5 - standard (DC)
3-25 lb-ft	8-105 lb-ft	6 - DTWP (DC)

TABLE 2
Components of Support Plate and Coil Assembly

Item	Description	Part Number	Torque (lb-ft)				
			6 10	15	25 50	35 75 105	
126	Support plate and bearing assembly	5-26-7006-00	1	1	1	1	
22	Solenoid lever stop	8-022-203-00	1	1	1	1	
76	Wrap spring stop	8-076-703-00	1	1	1	1	
76S	Screw (wrap spring stop) 10-24 x 1/2	9-25-7331-00	2	2	2	2	
79P	Spacer (solenoid)	8-179-705-00	1	1	1	0	
8	SOLENOID LEVER AND PINION KIT	5-66-7371-00	1	1	1	1	
170	Release plate	8-170-706-00	1	1	1	1	
170N	Nut (release plate) 1/4 x 20	9-40-3730-00	2	2	2	2	
170S	Cap screw (release plate)	9-15-1031-00	2	2	2	2	
171	Spacer (release plate)	8-141-707-00	2	2	2	2	
17	Lever arm assembly	5-17-7005-00	1	1	1	1	
130	Pivot pin (lever arm)	9-32-3111-00	1	1	1	1	
152P	Pivot pin (spring tube)	9-32-4059-00	1	1	1	1	
130B	Bearing (washer type)	8-138-701-00	2	2	2	2	
19 & 152	Pressure spring tube kit	5-66-7471-00	1	1	1	1	
11	Pressure spring kit – black	5-66-3072-00	1				
	Pressure spring kit – white	5-66-3074-00		1			
	Pressure spring kit – orange	5-66-3076-00			1		
	Pressure spring kit – purple	5-66-3078-00				1	
AC Brakes							
U	NO. 5 AC SOLENOID KIT	5-66-5052-00	1				
	NO. 6 AC SOLENOID KIT	5-66-5062-00		1	1		
	NO. 8 AC SOLENOID KIT	5-66-5081-00				1	
13B	Solenoid link	8-013-708-00	1	1	1		
	Solenoid link	8-013-709-00				1	
V	NO. 5 COIL KIT 60 HZ	115/230 Vac	5-66-6507-33	1			
		230/460 Vac	5-66-6509-33	1			
		115 Vac	5-66-6501-33	1			
		230 Vac	5-66-6502-33	1			
		460 Vac	5-66-6504-33	1			
		575 Vac	5-66-6505-33	1			
	NO. 6 COIL KIT 60 HZ	115/230 Vac	5-66-6607-33		1	1	
		230/460 Vac	5-66-6609-33		1	1	
		115 Vac	5-66-6601-33		1	1	
		230 Vac	5-66-6602-33		1	1	
		460 Vac	5-66-6604-33		1	1	
		575 Vac	5-66-6605-33		1	1	
NO. 8 COIL KIT 60 HZ	115/230 Vac	5-66-6807-33				1	
	230/460 Vac	5-66-6809-33				1	
	115 Vac	5-66-6801-33				1	
	230 Vac	5-66-6802-33				1	
	460 Vac	5-66-6804-33				1	
	575 Vac	5-66-6805-33				1	
XX**	Brake release interlock switch	5-57-5517-00	1	1	1	1	
DC Brakes							
W	No. 5 DC solenoid assembly	5-12-5558-00	1				
	No. 6 DC solenoid assembly	5-12-5568-00		1	1		
	No. 8 DC solenoid assembly	5-12-5589-00				1	
VV	No. 5 Coil Assembly	115 Vdc	5-96-6516-00	1			
		230 Vdc	5-96-6517-33	1			
	No. 6 Coil Assembly	115 Vdc	5-96-6616-33		1	1	
230 Vdc		5-96-6617-33		1	1		
No. 8 Coil Assembly	115 Vdc	5-96-6816-33				1	
	230 Vdc	5-96-6817-33				1	
X	DC switch assembly	5-57-5501-00	1	1	1		
Y	DC switch assembly	5-57-5503-00				1	
	Arc suppression module	5-57-5711-00	1	1	1	1	

**AC brakes with the brake release interlock (N.O.) switch Item XX use Item W solenoid assembly for switch mounting in place of Item U.

TABLE 3
Contents of Kits and Assemblies (contents may vary)

Letter Designation	Kit Description		
4	Friction disc kit – splined (5-66-8483-00) 1 – Friction disc		
3	Stationary disc kit (5-66-8372-00) 1 – Stationary disc		
J	Vertical above spring and spacer kit (5-66-3171-00) 9 – Vertical above mounting springs 9 – Vertical above spring spacers		
8	Solenoid lever and pinion kit (5-66-7371-00) 1 – Solenoid lever and pinion assembly 1 – Cotter pin 1 – Solenoid lever pivot pin 1 – Pivot pin retaining ring		
19 & 152	Pressure spring tube kit (5-66-7471-00) 1 – Pressure spring tube 1 – Pressure spring screw 1 – Spring tube pivot pin		
11	Pressure spring kit (5-66-307X-00) 1 – Pressure spring		
U	AC solenoid kit (5-66-50XX-00) 1 – Plunger 1 – Frame 3 – Solenoid mounting screws 3 – Solenoid mounting conical spring washers 1 – Solenoid link nut 1 – Drive lock pin (for #8 solenoid only) (<i>not shown</i>) 1 – Washer (for #8 solenoid only) (<i>not shown</i>)		
V	Coil kits (5-66-6XXX-33) AC coils 1 – Coil 2 – Plunger guides 2 – Plunger guide screws		
VV	Coil assembly (5-96-6XXX-33) DC coils 1 – Coil 2 – Plunger guides 2 – Plunger guide screws		
W	DC solenoid assembly (5-12-55XX-00) 1 – Plunger 1 – Frame 3 – Solenoid mounting screws 3 – Conical spring washers 1 – Solenoid link nut 1 – Cable clamp and screw		
X	DC switch assembly (5-57-5501-00 or 5-57-5503-00) 1 – DC switch 2 – Mounting screws 2 – Lock washers		
XX	AC switch assembly (5-57-5504-00 or 5-57-5506-00) (brake release interlock switch – N.O.) 1 – AC switch 2 – Mounting screws 2 – Lock washers		
Y	Arc suppression module (5-57-5711-00) 1 – Arc suppression module 1 – Cable strap		
A	Manual release kit (5-55-7002-00)	Roll pin	Retaining ring
	Spring anchor	Bearing	Release lever
	Release spring	"O" ring	
	Release arm		

TABLE 4
Complete support plate assembly*

	AC	DC
6 lb-ft	5-42-7119-00-05	5-42-7120-00-05
10 lb-ft	5-42-7121-00-05	5-42-7122-00-05
15 lb-ft	5-42-7123-00-06	5-42-7124-00-06
25/50 lb-ft	5-42-7125-00-06	5-42-7126-00-06
35/75/105 lb-ft	5-42-7127-00-08	5-42-7128-00-08

*All items shown in Table 2 except for coil kit.

Support Plate Assembly

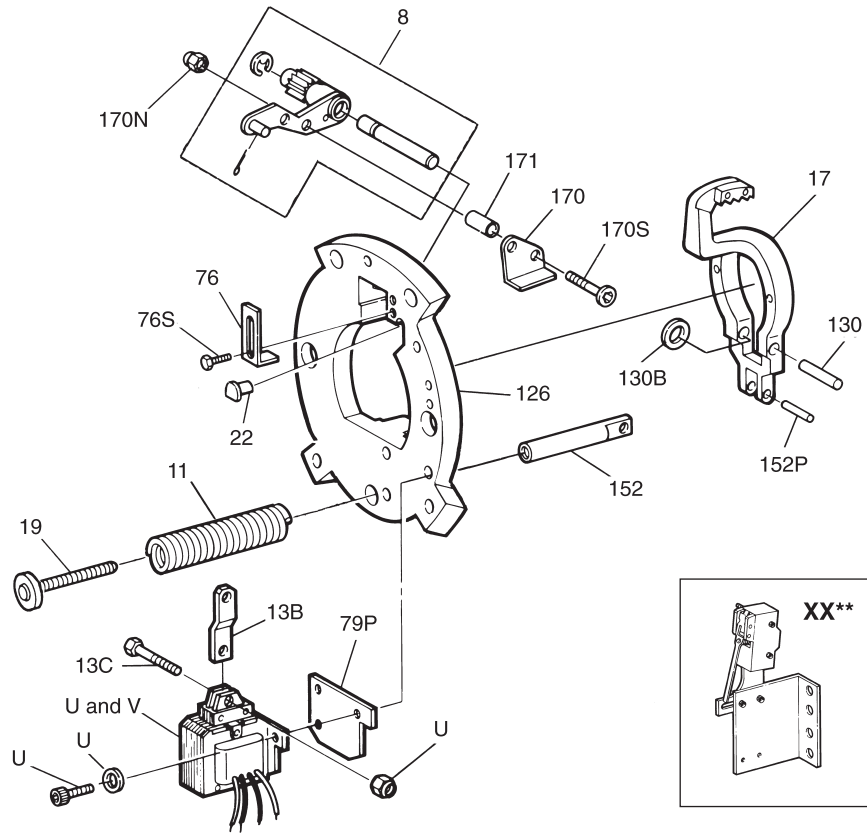

Solenoid and Coil

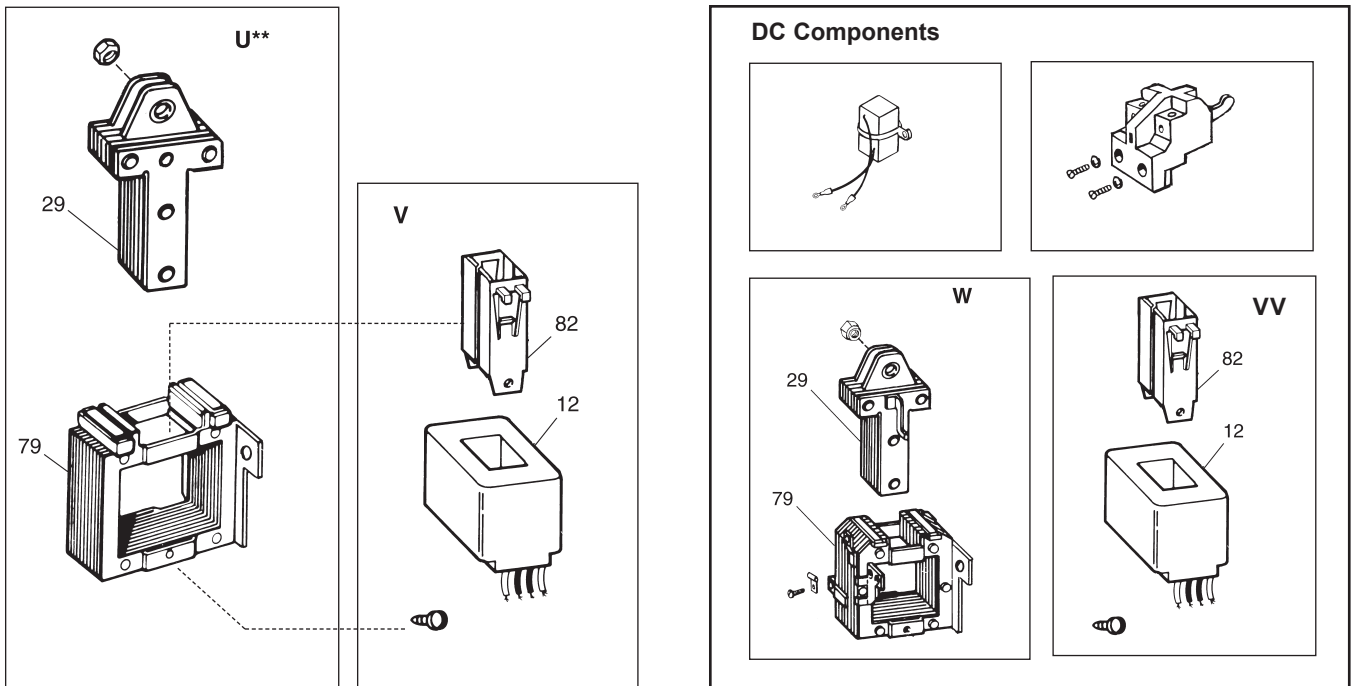

Rexnord Industries, LLC
 Stearns Division
 5150 International Dr.
 Cudahy, Wisconsin 53110
 (414) 272-1100 Fax: (414) 277-4364 www.stearnsbrakes.com