

Installation and Service Instructions for 48,100 Series Brakes (rev. A) (Models 1-048-151, 1-048-161 and 1-048-171)

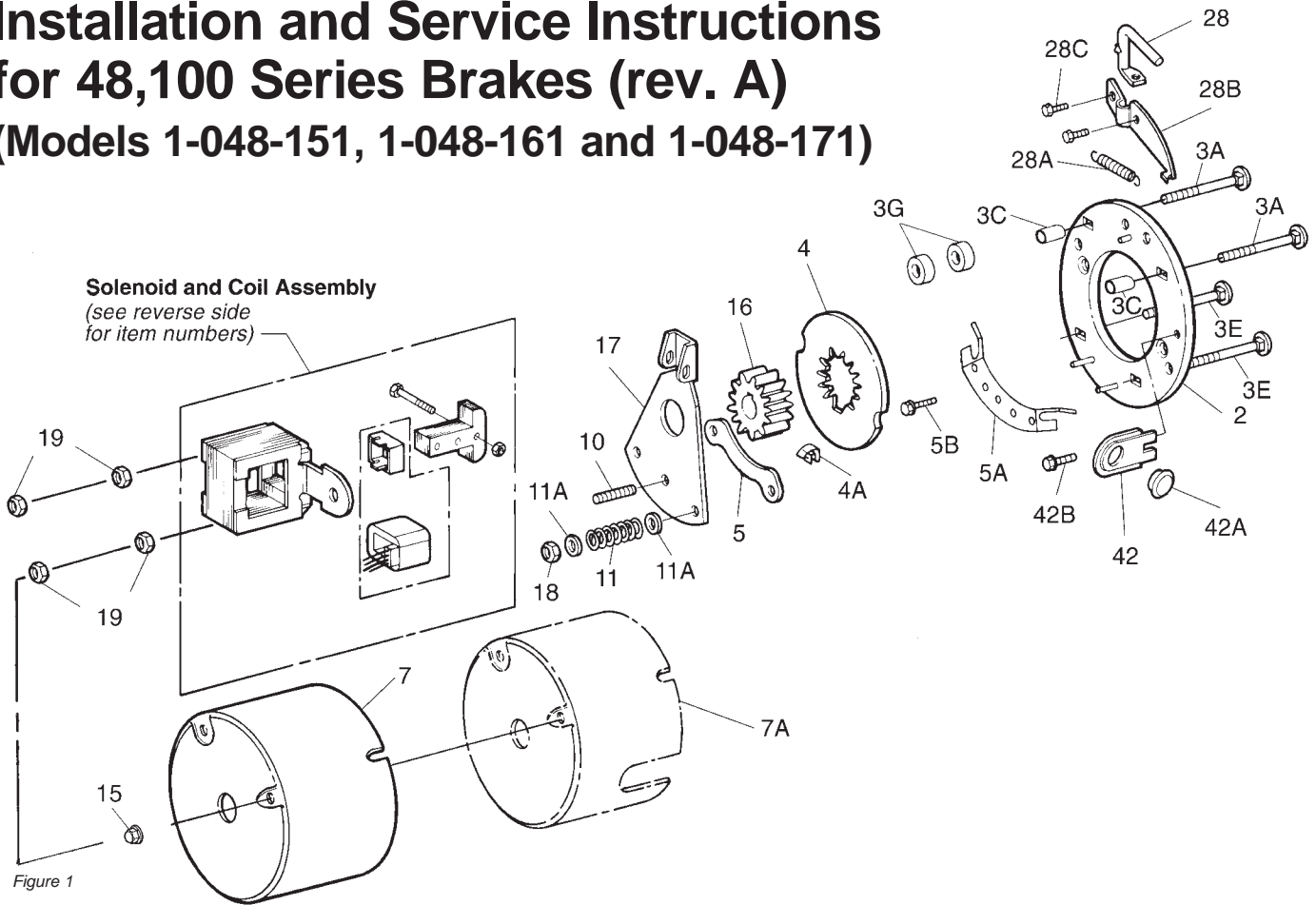

Important

Please read these instructions carefully before installing, operating, or servicing your Stearns brake. Failure to comply with these instructions could cause injury to personnel and/or damage to property if the brake is installed or operated incorrectly. For definition of limited warranty/liability, contact Rexnord Industries, LLC, Stearns Division, 5150 S International Drive, Cudahy, WI 53110, (414) 272-1100.

Caution

1. Installation and servicing must be made in compliance with all local safety codes including Occupational Safety and Health Act (OSHA). All wiring and electrical connections must comply with the National Electric Code (NEC) and local electric codes in effect.
2. Do not install the brake in atmospheres containing explosive gases or dusts, corrosive substances, water, oil or dust.
3. To prevent an electrical hazard, disconnect power source before working on the brake. If power disconnect point is out of sight, lock disconnect in the *off* position and tag

to prevent accidental application of power.

4. Be careful when touching the exterior of an operating brake. Allow sufficient time for brake to cool before disassembly. Surfaces may be hot enough to be painful or cause injury.
5. Do not operate brake with housing removed. All moving parts should be guarded.
6. After usage, the brake interior will contain burnt and degraded friction material dust. This dust must be removed before servicing or adjusting the brake.

DO NOT BLOW OFF DUST using an air hose. It is important to avoid dispersing dust into the air or inhaling it, as this may be dangerous to your health.

- a) Wear a filtered mask or a respirator while removing dust from the inside of a brake.
- b) Use a vacuum cleaner or a soft brush to remove dust from the brake. When brushing, avoid causing the dust to become airborne. Collect the dust in a container, such as a bag, which can be sealed off.

7. Installation and servicing should be performed only by qualified personnel familiar with the construction and operation of the brake.
8. For proper performance and operation, only genuine Stearns parts should be used for repairs and replacements.

General Description

The 48,100 series is a spring-set, electrically released disc brake for controlled stopping and holding of a load. It has a single-phase solenoid coil for operation on alternating current only. The nominal static torque is factory set.

Construction

The 48,100 series brake utilizes one composition friction disc driven by a metal hub that is fastened to the motor shaft. Manual release with automatic electrical reset is provided. Splined hub and friction disc is standard. Only open enclosure is available.

Operation

When brake is properly wired, starting the motor will energize the solenoid and compress the pressure spring. This action removes the force against the stationary plate and friction disc and allows the disc to rotate freely. Stopping the motor will de-energize the solenoid and restores

pressure spring force against the stationary plate and friction disc, stopping and holding the load.

Warning! Any mechanism or load held in position by the brake should be secured to prevent possible injury to personnel or damage to equipment before any disassembly of the brake is attempted or the manual release lever is operated on the brake.

When the motor is off and the load is to be moved without energizing the motor, the manual release lever can be rotated 90° away from the mounting face. This removes the retarding torque from the motor shaft, allowing the load to be moved. The brake will remain in the manual release position until the release lever is returned manually to its *set* position, or until the brake is re-energized electrically and the release lever returns to its *set* position automatically.

Note: The motor should not be run with the brake in the manual release position to avoid overheating of friction disc.

I. General Installation Notes

Brake mounting can be in any position. Brake is mounted with two 1/4" flat head socket cap screws mounted 180° apart.

II. Installation Procedure

1. Remove housing nuts (15) and housing (7) or (7A).
2. Remove hub (16) from brake and slide onto motor shaft and key (not furnished) to within 3/16" of motor mounting surface. Torque both set screws to 33 lb-in of torque.
- Note:** Check motor mounting face to be sure NEMA dimensions of 0.004" T.I.R. on concentricity and face run out are met. Shaft run out is to be within 0.002" T.I.R. Maximum shaft end float is 0.020".
3. Attach brake to mounting surface by sliding the brake friction surface (4) onto hub (16), engaging without force. Brake endplate (2) is to be tight against mounting face.
4. Mounting the brake to the mounting surface with two 1/4" flat head socket cap screws (not furnished). Notches are provided in the friction disc for accessibility to the mounting holes. Torque to screw manufacturer's recommendation based on materials being used. Screw heads may not protrude above wear surface. Brake mounting can be in any position.
5. Verify solenoid air gap is 1/8". Push in plunger and allow it to snap out. Check air gap. For vertical above motor mounting, see Note in *Wear Adjustment* Section. If adjustment is required, see *Wear Adjustment*.
6. See *Electrical Connection* for coil connection.

7. Replace housing.

III. Torque Adjustment

The brake is factory set for nominal rated torque. No further adjustment to increase torque may be made. The approximate compressed torque spring length to produce nominal rated torque is given in Table A.

Table A

Brake Torque (lb-ft)	Length "L" (in.)
1.5	1
3	15/16
6	1-1/8

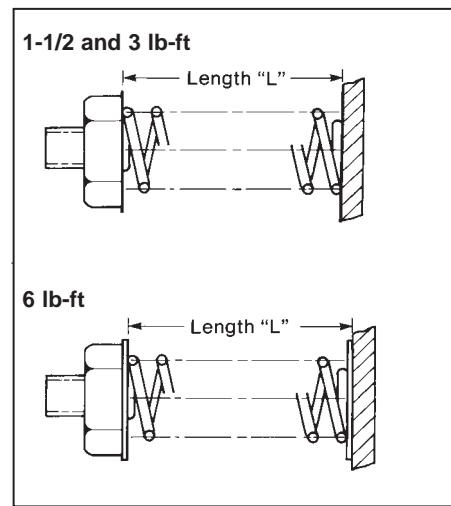

Figure 2

Note: 6 lb-ft measure 1.125" from base of lever (17) to top end of spring

To increase stopping time on 3 and 6 lb-ft brake, turn torque adjusting nuts (18) counterclockwise equal amounts to increase spring length. Spring studs equipped with flats on the end are for a wrench if the studs loosen during torque adjustment. For the 3 and 6 lb-ft brakes, one full turn on the nut will reduce the nominal torque approximately 15%. Do not reduce torque to less than 50% of nominal rated. Torque for the 1.5 lb-ft brake may not be reduced.

IV. Electrical Connection

CAUTION 1: Inverter Motor and Special Control Systems. This brake contains either a single phase AC coil or DC coil that requires instantaneous power within ± 10% of rating at the coil. A separate power source is required when this brake is used in conjunction with a motor or control system that limits voltage or current input (i.e. inverter motors) or causes a ramping of the power supply.

CAUTION 2: Class H coils with terminals. Do not bend lead wire crimp connection as this causes a fatigue in the metal which may break under vibration.

Note 1: Brake coil connections described here cover common motor connections. For nonstandard motor or control

connections contact respective supplier or Stearns Division.

Note 2: Be sure lead wires to coil are not tight or pinched, and that leads will not be rubbed by friction disc, trapped between solenoid plunger and frame, caught between lever arm and endplate, or by linkage.

General

All coils are single-phase alternating current (AC).

Single voltage coil connection

Connect coil (12C) to any two wires of a single-phase or three-phase power source of appropriate voltage. For operation with a motor control, connect to any two motor leads with correct voltage.

Dual voltage coil connection

Preconnect coil for appropriate high or low voltage as shown in Figure 3. On these coils observe the lead numbering sequence for proper connections as follows:

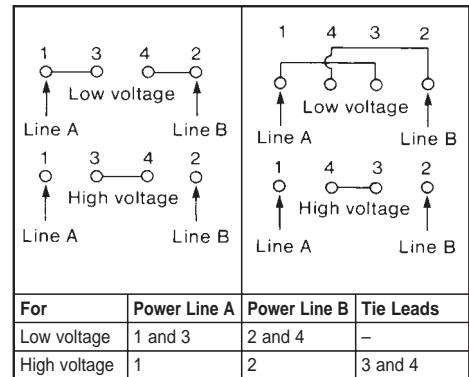

Figure 3

Connecting AC solenoid coils on dual voltage 230/460 three-phase motors

To use a 230 volt coil (or a 230/460 dual voltage coil connected for 230 volts) with a 230/460 dual voltage three-phase motor, the brake leads are connected across two motor terminals as shown, or other equivalent combinations. If a 230 volt brake coil is connected as shown in Figures 4 or 5, the motor can be operated on either 230 volts or 460 volts with no effect on brake operation.

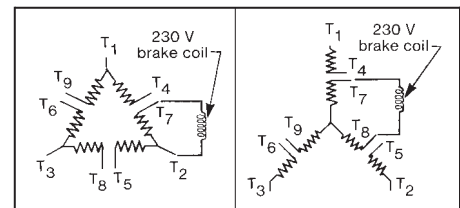

Figure 4

Figure 5

V. General Maintenance

1. **Warning!** Any mechanism or load held in position by the brake should be secured to prevent possible injury to personnel or damage to equipment

before any disassembly of the brake is attempted or before the manual release lever is operated on the brake.

2. Observe all cautions listed at the beginning of this manual before attempting to service brake.
3. Remove housing screws (15) and housing (7) or (7A).

Wear adjustment

1. Normal friction disc wear will cause solenoid air gap to become larger from the original set 1/8" ~ 5/32" air gap. An increase in stopping time and a slight reduction in torque will consequently occur. See Figure 6.
2. When the solenoid air gap increases to 1/4", the brake must be adjusted. The gap is measured between the mating ground surfaces of the solenoid frame and solenoid plunger.

Note: To measure air gap on brakes mounted vertical above motor, push plunger into frame until spring pressure is felt. Holding firmly in this position, measure air gap between mating (ground) surfaces on solenoid frame and solenoid plunger. If adjustment is made, check air gap by again holding plunger as directed.

3. To decrease air gap, turn the wear adjusting screw (10) clockwise until an air gap of 1/8" minimum is attained. To increase gap, turn screw counterclockwise.
4. After adjustment, push in plunger and allow it to snap out. Recheck air gap, see Note.
5. Replace friction disc when wear area is one half original disc thickness of 3/16".

Friction disc replacement

1. Disconnect power source to brake.
2. Align friction disc (4) notches with the two 1/4" flat head cap screws. Remove

the screws and slide entire brake off motor and hub.

3. Remove housing support nut (19) and solenoid mounting nut (19) from one side of the solenoid mount. Slide carriage bolt (3A) out the backside of the endplate (2). Remove solenoid spacer (3C) and shock pad (3G).
4. Slide old friction disc out the side of the brake assembly.
5. Insert new friction disc between endplate (2) and stationary plate (5). Reassemble brake in reverse order of Steps 2 & 3. Tighten the solenoid mounting nut (19) to 15 lb-in to compress the shock pad (3G).

Note: If solenoid buzz is noted, readjust solenoid mounting nut (19) to "tune out" the buzz.

6. See *Wear adjustment*. It may be necessary to turn wear adjust screw (10) CCW for clearance.
7. Reposition the housing support nut (19) .165" from the top of the housing bolt.
8. Replace housing.
9. Restore power to brake.

Coil or solenoid assembly replacement

1. Disconnect coil (12C) from circuit.
2. Cut the plastic wire tie holding the coil leads onto the housing stud (18).
3. Remove housing and solenoid mounting nuts (19) and lift solenoid / coil assembly off the mounting bolts.
4. Remove plunger guide (82A) by lifting out of top of solenoid frame. Coil (12C) has a lock tab, located at top of coil opposite lead wire side, which is pressed against coil and coil is slid sideways from solenoid frame.
5. For coil replacement, inspect and clean solenoid assembly. Install the new coil in original solenoid frame or original coil in new solenoid frame with

the lead wires positioned as before. Install plunger guide(s) in reverse order of (4).

- 5A. For solenoid assembly replacement, remove plunger screw (9) and plunger nut (9B). Install new plunger (29A) with new plunger screw and nut.

6. Reassemble brake in reverse order of Steps 1, 2 and 3. Tighten solenoid mounting nuts (19) to 15 lb-in of torque to compress the shock pad (3G).

Note: If solenoid buzz is noted, readjust solenoid mounting nut (19) to "tune out" the buzz.

7. Reposition the housing support hot (19) .165" from the top of the housing bolt.
8. Replace housing.
9. Restore power to brake.

VI. Troubleshooting

A. If brake does not stop shaft properly or overheats, check the following:

1. Is brake manually released rather than electrically released while motor is running?
2. Is friction disc excessively worn, charred, or broken?
3. Has hub become loose and shifted on shaft?
4. Is hub clean, and does friction disc slide freely?
5. Does stationary plate slide freely on guide pins?
6. Are pressure springs improperly assembled, or broken?
7. Is solenoid air gap adjusted correctly? See *Wear Adjustment*.
8. Does solenoid linkage move freely?
9. Is voltage supply at coil correct?

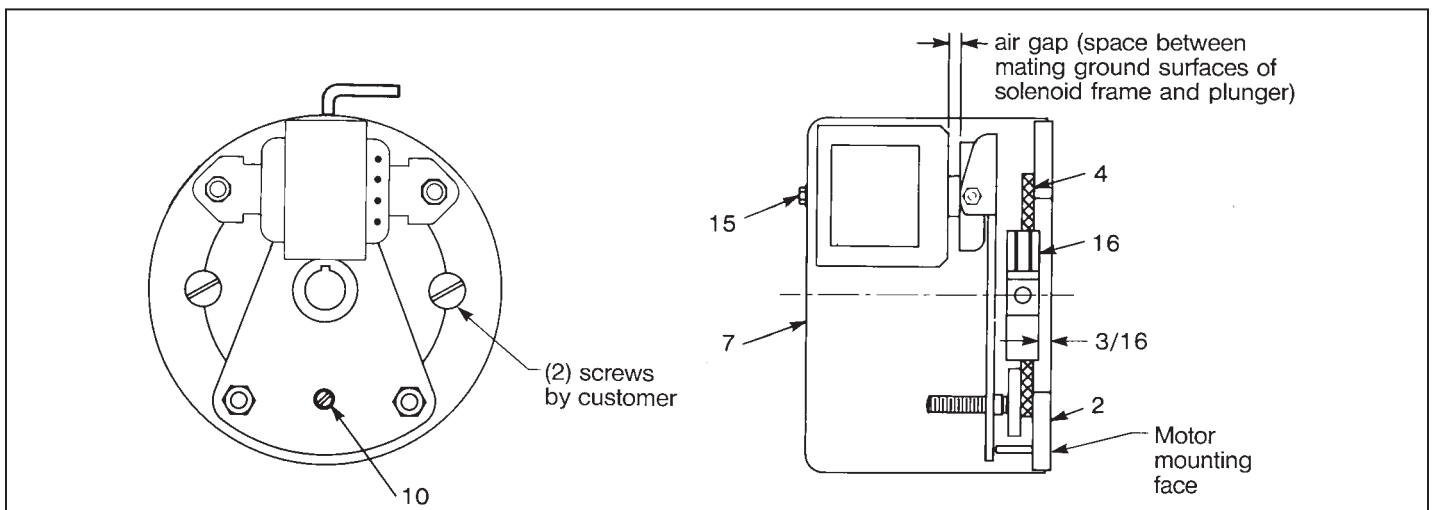

Figure 6

10. Are controls which govern start or stop of braking cycle operating properly?
11. Is brake coil energized at same time or prior to energization of motor, and de-energized at same time or after de-energization of motor?
12. Is stopping time more than one second (rule of thumb) and/or is application more than five stops per minute? If so, consult factory. Check thermal requirements of load versus thermal rating of brake.
13. Replace friction disc when worn area is one half of original thickness of 3/16".
7. Housing studs may have become loose causing frame to shift and plunger to seat improperly.
8. Does solenoid linkage move freely?
9. Check for excessive voltage drop in motor line when motor is started. Check wire gauge of supply line against motor starting current and solenoid inrush current. Measure voltage drop at solenoid coil leads during maximum inrush current condition. To accomplish this, connect voltmeter at brake coil. Insert a block of wood, or other non-magnetic material, between solenoid plunger and frame. Block thickness should approximately equal solenoid air gap. Energize motor and brake simultaneously, take reading and immediately shut down. (This is to prevent motor, brake, or solenoid burn up, since brake will be set during procedure.)

B. If brake hums, solenoid pulls in slowly, or coil burns out, check the following:

1. Voltage supply at coil versus coil rating and connection.
2. Is solenoid air gap excessive?
3. Shading coils may be broken.
4. Plunger guides may be excessively worn. Does solenoid plunger rub on solenoid frame laminations?
5. Solenoid frame and plunger may be excessively worn.
6. Is solenoid dirty?

C. If disc noise occurs, check:

1. If friction disc (4) becomes noisy, check stabilizing spring (4A) to be sure it is installed.
2. Check that the leaf spring (5A) is supporting stationary plate (5). If distorted, replace.