

Installation and Service Instructions for 65,300 and 65,000 Series Brakes

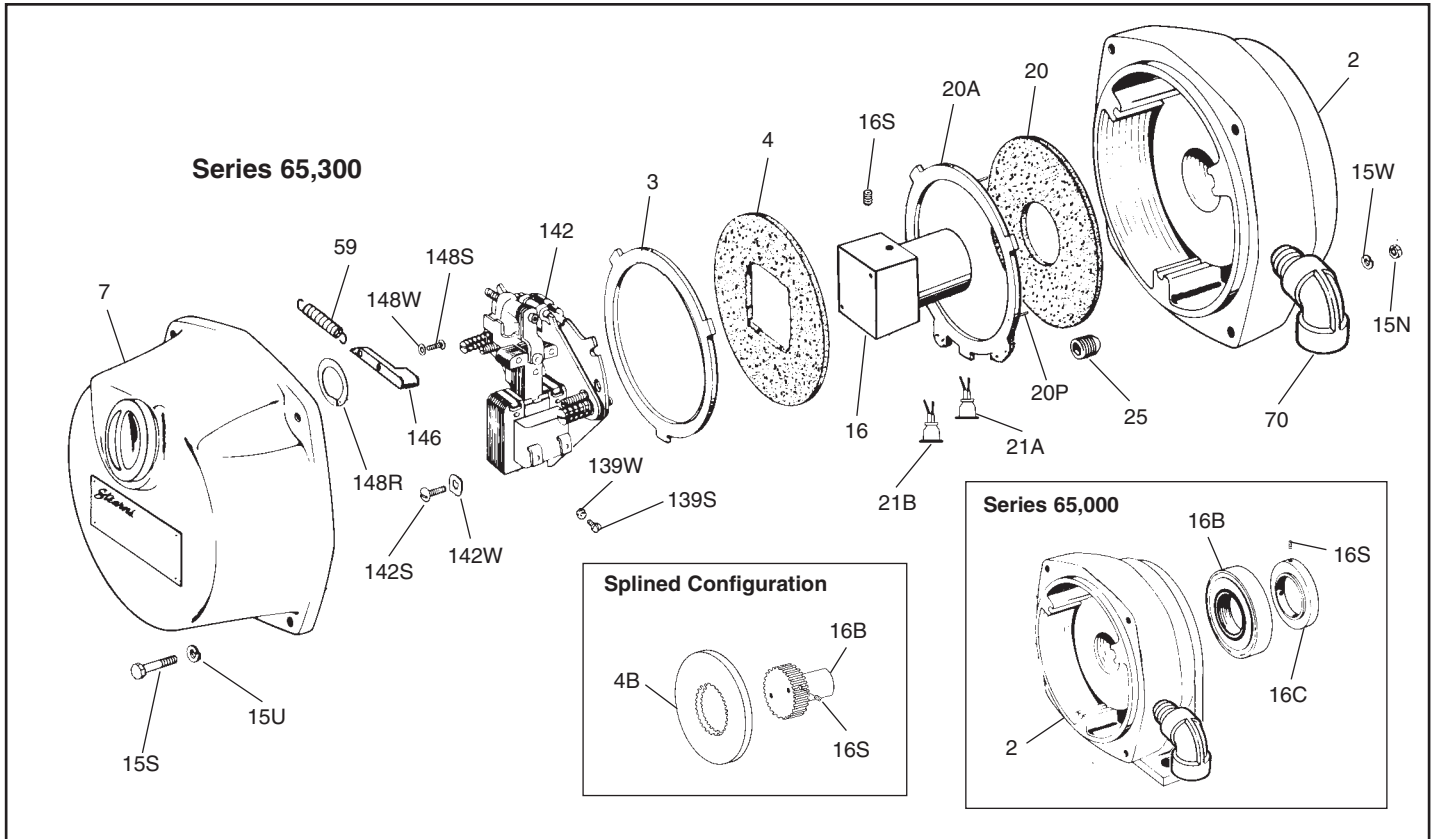

Figure 1

Important

Please read these instructions carefully before installing, operating, or servicing your Stearns Brake. Failure to comply with these instructions could cause injury to personnel and/or damage to property if the brake is installed or operated incorrectly. For definition of limited warranty/liability, contact Rexnord Corporation, Stearns Division, 5150 S. International Dr., Cudahy, Wisconsin 53110, (414) 272-1100.

Caution

- Installation and servicing must be made in compliance with all local safety codes including Occupational Safety and Health Act (OSHA). All wiring and electrical connections must comply with the National Electric Code (NEC) and local electric codes in effect. For additional information refer to the Underwriters Laboratory (UL) website at: <http://www.ul.com/hazloc/codes.html>
- Do not install brake in a hazardous location other than that as designated. To prevent ignition of hazardous atmospheres, disconnect the product from the supply circuit before opening. Keep assembly tightly closed when in operation. Also to prevent an electrical hazard, disconnect power source before working on the brake. If power disconnect point is out of sight, lock disconnect in the *off*

position and tag to prevent accidental application of power.

- Make certain power source conforms to the requirements specified on the brake nameplate.
- Be careful when touching the exterior of an operating brake. Allow sufficient time for brake to cool before disassembly. Surfaces may be hot enough to be painful or cause injury.
- Do not operate brake in hazardous atmosphere with housing removed and supply circuit connected.
- Installation and maintenance should be performed only by qualified personnel familiar with the construction and operation of the brake.
- For proper performance and operation only genuine Stearns parts should be used for repairs and replacements.
- After usage, the brake interior will contain burnt and degraded friction material dust. This dust must be removed before servicing or adjusting the brake.

DO NOT BLOW OFF DUST using an air hose. It is important to avoid dispersing dust into the air or inhaling it, as this may be dangerous to your health.

- Wear a filtered mask or a respirator while removing dust from the inside of a brake.

- Use a vacuum cleaner or a soft brush to remove dust from the brake. When brushing, avoid causing the dust to become airborne. Collect the dust in a container, such as a bag, which can be sealed off.

General Description

Stearns Series 65,300 and 65,000 are spring-set, electromagnetically released disc brakes. The brake is listed by Underwriters Laboratories, Inc. for hazardous locations. The Class and Group designation is shown on nameplate. The listing includes two types of brakes, one for attachment to a listed motor at that motor manufacturers factory and the foot mounted type which is complete, and can be mounted on a common base and joined to a motor. The listing marks on the brake apply only to the brake, not to the driving equipment. In the case of a motor mounted brake neither brake nor motor are listed unless both are listed. The listing marks of both the brake and the motor must be in agreement as to the Class and Group rating.

The brake is essentially designed for holding purposes but may be used for stopping light inertia loads. The brake has a single-phase Class A only solenoid coil for operating on alternating current only.

The nominal static torque is factory set.

The brake is not waterproof and protection from the weather and other conditions is required.

Operation

Each brake assembly consists of one to three molded friction discs fitted over a hub attached to or driven by a motor shaft. The friction disc(s) are located alternately between an endplate and stationary disc(s). The stationary disc(s) are restrained from rotating by slots in the endplate. A solenoid, lever system, and pressure springs are located on a support plate. A fitted housing, attached to the endplate, encloses the working parts.

The release of the brake occurs when the solenoid coil is energized causing the solenoid plunger to travel a specified distance and, through the lever system, overcome the pressure spring force. The lever system in its travel disengages from the stationary disc which permits the friction discs to rotate when the motor is energized. When the motor and solenoid coil are de-energized the pressure springs move the lever system toward the pressure plate, applying a force to stop the rotation of the friction discs. Periodic adjustment for friction disc wear is required.

The brake is equipped with a manual release knob which, when activated, sufficiently releases the brake without energizing the solenoid coil, permitting manual movement of the drive system, however drag may be noted. When the solenoid is energized the manual release knob returns to its initial position or may be manually reset and permits the brake to set when the solenoid coil is again de-energized.

Note: The motor should not be run with the brake in the manual release position to avoid overheating of friction discs.

I. Installation

(Series 65,300 - See Figures 1 and 2)

Note 1: For proper operating in the horizontal position, mount brake so that solenoid plunger (29) is above the frame (79) when installed. If motor is to be ceiling or horizontally wall mounted, brake must be oriented so the brake plunger is above frame when motor is installed. The brake may be mounted, if specifically modified, vertically above or vertically below the motor. A one disc brake vertically above or below motor is not modified.

Note 2: The motor mounted brake must be mounted on a C-face surface. The face run out should be within 0.004" F.I.M. (Full Indicator Movement). The eccentricity of the mounting rabbet should be within 0.004" F.I.M. The shaft run out should be within .002" F.I.M. Maximum permissible endfloat is 0.020".

1. Remove housing screws (15S), washers (15U), lock washers (15W) and hex nuts (15N). Then pull straight back on housing (7) to remove it.
2. Disconnect solenoid coil leads and remove support plate assembly (142) by

unscrewing and removing screws (142S) and lock washers (142W).

3. Remove stationary disc (3), friction disc(s) (4), stationary disc(s) (3), if used, and hub (16).

Note 3: Vertically mounted brake (multi disc) will have special pins which hold spacer springs. Note color coded sequence of springs. Refer to instruction sheet, P/N 8-078-935-05 for proper sequence of vertical mounting components.

4. Attach endplate (2) to motor mounting face using four 3/8-16 socket head cap screws (not supplied). See Note 1. Torque to 545 in-lb. After securing endplate install four mounting bolt set screws (25) over heads of socket head cap screws, tighten securely.
5. Position hub (16) over a full length fitted key (not supplied) on the motor shaft so that the inboard square face of the hub is 1/16" from heat barrier (20) face. Torque both set screws (16S) to 36 in-lb.

Caution: Because of the small diametral clearance between hub turn and inside diameter of endplate, check that the hub is free to rotate without binding or interference. Also check that hub does not touch or rub heat barrier (20).

6. Reassemble friction disc(s) (4), springs (if vertical mounting style), and stationary disc(s). Check that all disc pack components can slide freely.
7. Mount support plate assembly (142) with screws (142S) and lock washers (142W), drawing screws down evenly, torque to 43 lb-in.

Check that assembly is mounted with the solenoid in a vertical position, plunger (29) above frame (79), if brake-motor is to be floor-mounted in a horizontal model. See Note 1.

8. Refer to Section V, under A. *Adjustment for Friction Disc Wear*, Table 2. If gap adjustment is necessary, follow Step 2.
9. See Section III, *Electrical Connection*, for solenoid coil and thermostat wiring details.
10. Check that friction disc(s) are able to rotate freely when solenoid plunger is depressed firmly into frame. If binding or drag occurs, recheck Steps 5, 6 and 8.
11. Reinstall housing by first rotating it so that release knob is approximately 20° counterclockwise from vertical centerline, before installing it on brake. Then slide housing over register, rotate clockwise and align bolt holes.

Note 4: If brake is upside down for later ceiling mount, turn brake upright before installing housing.

Check manual release ease of operation by rotating knob 90° clockwise and return. If difficult, correct and reinstall housing.

Replace hardware removed in Step 1. Tighten bolts securely.

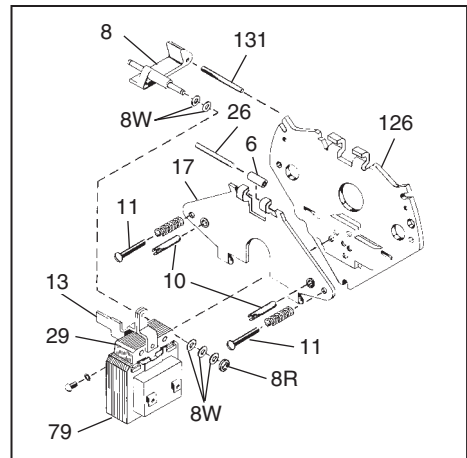

Figure 2

II. Installation

(Series 65,000 - see Figures 1 and 2)

Note 1: The 65,000 Series foot mounted brake is designed and intended for attachment to an independently supported shaft. To prevent preload and failure of internal brake hub bearing, it is important that correct alignment is achieved upon installation. Do not use brake bearing as a load support. Minimum shaft-to-hub-bore engagement should be 1.5 times the shaft diameter, E.G., a 5/8" diameter shaft should penetrate hub bore at least 15/16".

Note 2: The brake is to be installed only horizontally - either wall mounted or with feet on floor position.

Note 3: To maintain alignment and to facilitate future removal and reinstallation, the use of dowels is recommended to position floor stand and pillow blocks.

Steps 1 and 2 offer possible methods of installation.

1. On a pillow block bearing supported shaft installation, locate, align and mount brake. Then slide shaft into hub with fitted key for an appropriate distance. Obtain a free, sliding fit, by adding or removing shims on a trial-and-error basis below pillow blocks. When a satisfactory fit is obtained, tighten hub bearing lock collar set screws (16S) to 36 in-lbs torque and pillow block bearing lock collars.
2. Coupling the brake to a fixed supported shaft. See Notes 1, 2 and 3. Install a shaft and key of proper dimensions, having recommended or more required length into the brake hub. Torque the two lock collar set screws (16S) to 36 in-lbs. Align the two shafts in accordance with the coupling manufacturer's specifications.
3. Follow Steps 1, 8, 9, 10 and 11 of *Installation* (Series 65,300).

III. Electrical Connection

Caution! Do not rotate conduit box (70). Wire breakage will occur due to seal in the conduit.

Note 1: Brake coil connections described here cover common motor connections. For nonstandard motor or control connections contact respective supplier or Stearns Div.

Note 2: On brakes with space heater, connect to appropriate power source. Heater is to be energized continuously, even during storage, or rust may occur.

Note 3: Be sure lead wires to coil are not tight or pinched, and that leads will not be rubbed by friction disc, trapped between solenoid plunger and frame.

1. Single voltage coil connection

Connect coil to any two wires of a single-phase or three-phase power source of appropriate voltage. For operation with a motor control, connect to any two motor leads with correct voltage.

2. Dual voltage coil connection

Preconnect coil for appropriate high or low voltage as shown in Figure 3. On these coils observe the lead numbering sequence for proper connections as follows:

AC Voltage Coil Connection

Class H Coil (colored)

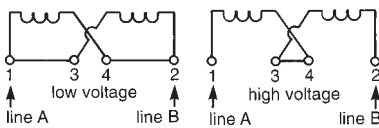

For	Power Line A
Low Voltage	1 and 3
High Voltage	1

Figure 3

3. Connecting AC solenoid coils on dual voltage three-phase motors

To connect a dual voltage coil through the windings of a dual voltage motor, configure the coil to match the low voltage rating of the motor as shown in Figure 3. (Single voltage coils should be equal to the low voltage rating of the motor). Connect the brake coil across the motor windings as shown in Figure 4. Operation of the motor at either voltage will properly operate the brake coil.

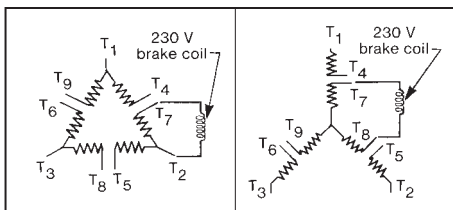

Figure 4

4. Thermostat connections

(Series 65,300 only)

The proper connection of thermostats TSW-1 (yellow leads) and TSW-2 (red leads) is shown in the wiring diagram, Figure 6.

IV. Torque Adjustment

The 65,XXX Series Brakes are factory set for nominal rated torque which is maximum torque. Torque may be decreased for increased stopping time per Table 1. The torque on the 1-1/2 lb-ft brake may not be reduced.

Note 1: Torque adjust screws on older brakes are 1/4" shorter than shown in Table 1. For replacement screws use part number 8-009-501-00 and specify 2" length needed.

WARNING: The thermal protector TSW2 (21A) mounted in this brake must be wired into control circuit to limit the brake external surface temperature.

Thermostat TSW1 (21B) indicates high friction disc temperature, duty cycle should be reduced. When friction discs become abnormally hot, switch TSW2 will open motor circuit and cause brake to engage. In extremely moist atmospheres a heater is recommended and should remain energized continually.

Rating Optional Heater	
Volts	Amps*
120	.23
230	.13

Rating TSW1 & TSW2
720VA Hi-pot test Voltage 1250 Maximum

*May vary ± 10%

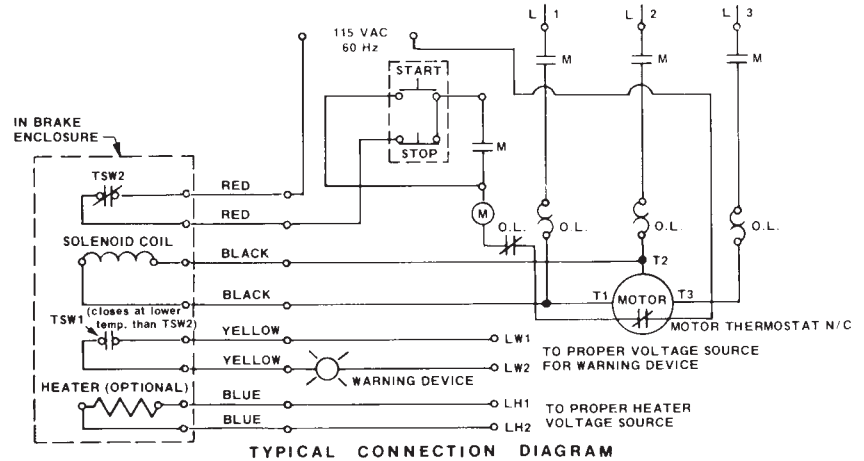

Figure 6

Table 1

Series	Nominal Standard Torque (lb-ft)	Maximum Counterclockwise Turns	% Torque Reduction per Turn	Torque Adjust Screw Length (inches)	Original Spring Height (inches)
65,000 & 65,300	3, 6 and 10	3	16	2	1
	15	2	16	2	7/8

Note 2: Both adjustment screws (11) on Figure 7 must be turned equal amounts counterclockwise to decrease torque.

V. General Maintenance

Warning! Any mechanism or load held in position by the brake should be secured to prevent possible injury to personnel or damage to equipment before any disassembly of the brake is attempted or before the manual release knob is operated on the brake.

Caution! Observe all cautions listed at the beginning of this manual before attempting to service brake.

A. Adjustment for friction disc wear

1. Remove housing bolts, associated hardware and housing.
2. Manually lift solenoid plunger to maximum travel. Depress and allow solenoid plunger to snap out several times. See Figure 7. Measure solenoid air gap between mating surfaces of solenoid frame and solenoid plunger. (On vertically mounted brakes, it will be necessary to push solenoid plunger into solenoid frame to the point where spring pressure is felt, before measuring solenoid air gap.) As friction disc wear occurs the air gap will increase, as well as stopping time. If solenoid air gap exceeds 11/16", adjustment is necessary.

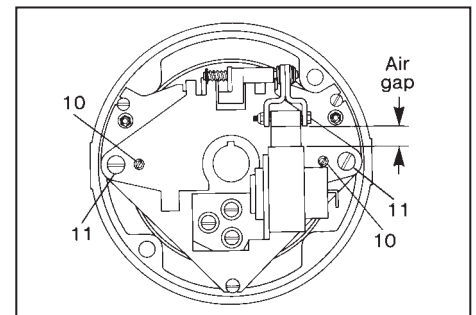

Figure 7

The solenoid air gap measurements are shown in Table 2.

Table 2: Solenoid Air Gap Measurements

Nominal Static Torque (lb-ft)	Series 65,000 and 65,300
1.5; 3	13/32
6	1/2
10	9/16
15	9/16

3. The solenoid air gap may be decreased by turning both wear adjustment screws (10) equal amounts clockwise, approximately 1/8 turn, until approximate solenoid gap is attained. Counterclockwise rotation will increase gap. See Figure 7. Repeat Step 2.
4. Follow Step 11 of *Installation Procedure*, Section I to replace housing.
5. Restore power source.

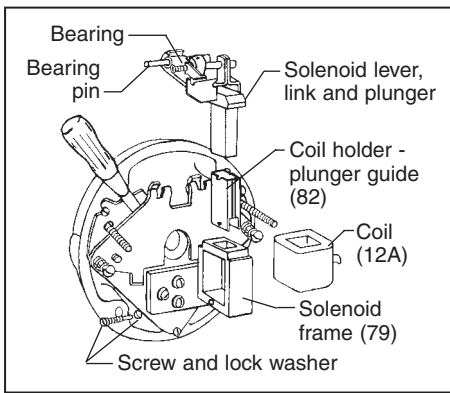

Figure 8

B. Inspection or replacement of solenoid and associated components

1. Refer to Figures 2 and 8. Insert screwdriver between support plate (126) and lever arm (17). Wedge apart and remove bearing pin (26), bearing (6), pin (131) and solenoid lever (8), connected to solenoid link (13) and plunger (29).
2. To remove coil (12A), unscrew plunger guide screw and lock washer. Remove both plunger guides by prying up on the flanges. Slide coil (12A) sideways from frame and note position of coil terminals.
3. Inspect and clean all items. If coil, plunger guides, or solenoid replacement is required, refer to Parts List P/N 8-078-913-03 for the Series 65,300, or P/N 8-078-913-04 for the Series 65,000, and select appropriate replacement kit or assembly. Most kits or assembly packets contain full retrofit instructions.
4. Reassemble brake in reverse order of Step 1 and 2.
5. Follow Step 11 of *Installation Procedure*, Section I, to replace housing.
6. Restore power source.

C. Replacement of friction discs

See *General Maintenance*, Section V. Warning and Caution. Follow Steps 1 through 3 and 6 through 11 of *Installation Procedure*, Section I, but do not remove hub in Step 3.

D. Replacement of heat barrier and insulator disc

1. Follow Steps 1 through 3 of the *Installation Procedure*, Section I.
2. Remove the thermostats (on the 65,300 Series only) by removing mounting screws.
3. Using a screwdriver, pry evenly around insulator disc (20A) until free of spring pins (20P) and lift out.
4. Remove spring pins. (Using pliers, pull and twist until pins are free, if still in endplate.)
5. Remove heat barrier (20) and clean endplate surfaces as required.
6. Position new heat barrier and insulator disc. Be sure holes for spring pin line up

with drilled holes in endplate.

7. Install spiro pins using a 1/8" drift punch to drive in pins until flush with surface of insulator disc. Reinstall the thermostats (on 65,300 Series only).
8. Follow Steps 6 through 11 of *Installation Procedure*, Section II.
9. Restore power source.

VI. Troubleshooting

A. If brake does not stop properly, coasts, or overheats:

1. Check that manual release knob is not jammed in release mode. Check release mechanism for paint, dirt, etc. and clean if required.
2. Check for excessively worn, charred or broken friction discs.
3. Check that hub has not loosened and shifted on motor shaft on Series 65,300 or hub lock collar loosened on 65,000.
4. Check that friction discs slide freely over hub. Clean hub and/or file friction discs as required, if overheated replace.
5. Check that stationary disc(s) can move freely in endplate and that they are not warped from overheating.
6. Check endplate slots for wear in the area where stationary disc(s) and/or pressure plate make contact. Grooves in slots can prevent free disc movement and result in torque loss or friction disc breakage.
7. On vertically mounted brakes, check that springs are installed correctly and that stationary disc(s) can slide freely over vertical mounting pins. Consult P/N 8-078-935-05 for further details.
8. Check length of pressure springs. For nominal torque rating compressed spring height, see Table 1.
9. Check solenoid air gap against Table 2 in Section V, under A, Step 2. Adjust if necessary.
10. Check that solenoid linkage can move freely. It requires approximately 3-1/2 lbs of pressure to seat solenoid plunger to frame on a correctly functioning brake.
11. Check that solenoid lever bearing (6) and pivot pins (26 and 131) are in place on support plate assembly (142).
12. Check voltage reading at coil terminals against coil voltage rating.
13. Check that brake coil is energized at the same time as, or prior to, motor and de-energized at the same time, or after, motor.
14. If stopping time exceeds one second, or if the application requires more than two stops per minute, check the thermal requirements to stop load against the thermal capacity of the brake.
15. If, on the Series 65,300, thermostat TS1 closes, or TS2 opens, recheck Items A-3

through A-14.

16. Replace friction discs(s) when worn area is one half of original thickness (3/16").
17. Check to be sure wear adjust screws are of equal height. Measure from inboard side of support plate with depth micrometer. Turn one screw to obtain equal height, reassemble and see *Adjustment for Friction Disc Wear*.
18. Check to be sure insulator disc (20A) has not loosened. Also check thermal switch TSW2 (red leads) is closed and is wired into the circuit.

B. If brake hums, solenoid pulls in slowly, or coil burns out:

1. Check Items A-9, A-10 and A-12.
2. Check if shading coils at top of solenoid frame (79) are broken and for worn plunger guides or if plunger rubs on solenoid frame laminations.
3. Check for worn or dirty solenoid plunger and frame, also for loose screws holding frame.
4. A voltage drop may be occurring. If excessive drop in voltage is noted, check wire size of power source. Correct as needed.

Note: A method to check voltage at coil is to insert a block of wood of the approximate thickness of the solenoid air gap between the solenoid frame and plunger. (The block will prevent brake from releasing when coil is energized.) Connect voltmeter leads at the coil terminals or lead wires. Energize coil. Voltmeter needle will not fluctuate and reading can be taken. Reading should be taken immediately and the coil de-energized to prevent overheating of the coil. Compare voltage reading with coil rating. Since brake will be energized during this procedure, be sure a nonexplosive atmosphere exists at time of test or DO NOT PERFORM!

C. If brake is noisy during stopping and/or friction discs shatter:

1. On floor-mounted Series 65,000, recheck alignment and condition of hub bearing (16B). Refer to Section II, Items 1 and 2.
2. On both series check hub position on shaft. The inboard square face of hub should be 1/16" from face of heat bearing (20).
3. On Series 65,300 remove hub (16) and check turned shoulder O.D. for evidence of rubbing endplate (2) clearance hole. If rub marks are found, check concentricity of motor C-face register. See *Installation*, Note 2.