

## Installation and Service Instructions for 81,000 Series Brakes

Spring arrangement for vertical mounting for standard friction discs with cast iron pressure plate and stationary disc(s). For other combinations of material consult factory.

### Spring arrangement for vertical mounting above motor.

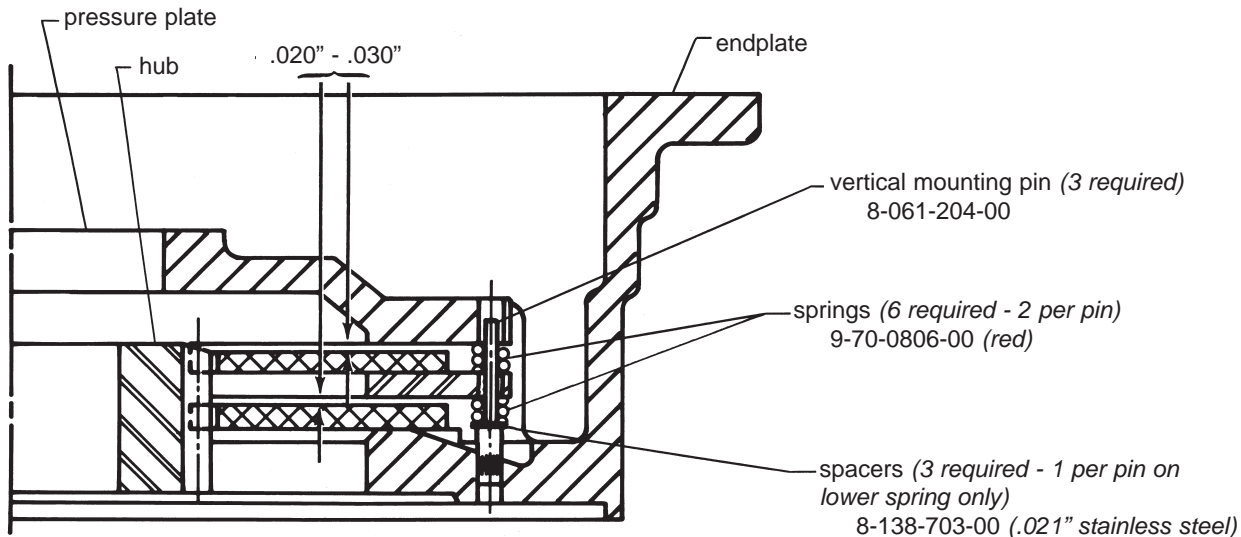

2 friction discs

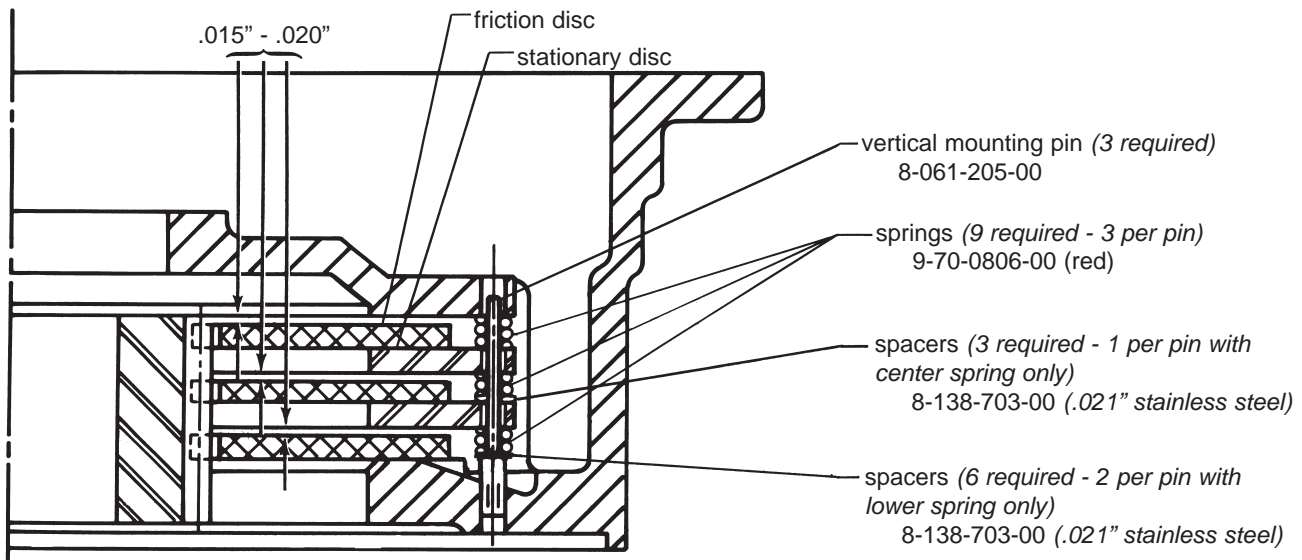

3 friction discs

#### Notes:

1. Follow Installation and Service Instruction Sheet No. 8-078-921-00 for assembly of brake to motor.
2. Dimensions shown above are assembled clearance dimensions. Disc pack can be set up on a flat surface to obtain or check them. They may be somewhat greater in a free position, but must be equal.
3. Check to make sure that shoulder of vertical mounting pins and endplate friction surface are flush. Friction discs must be free to rotate. Check by rotating hub,

if possible, and compress disc pack to make sure that components slide freely over pins. If springs do not return components, pins may be bent, and will have to be straightened.

4. For part numbers of endplate, stationary disc, and pressure plate, refer to Parts List No. 8-078-921-00, under vertical mounting above motor.

**Caution!** Conversion from horizontal to vertical mounting should not be attempted in the field without consulting factory.

## Spring arrangement for vertical mounting below motor

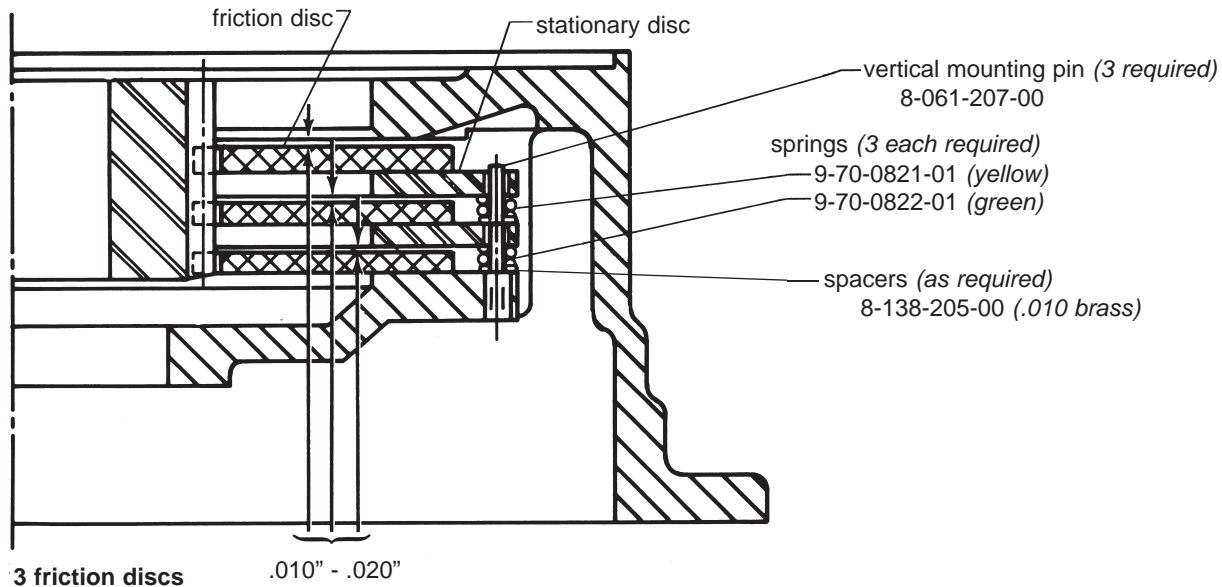
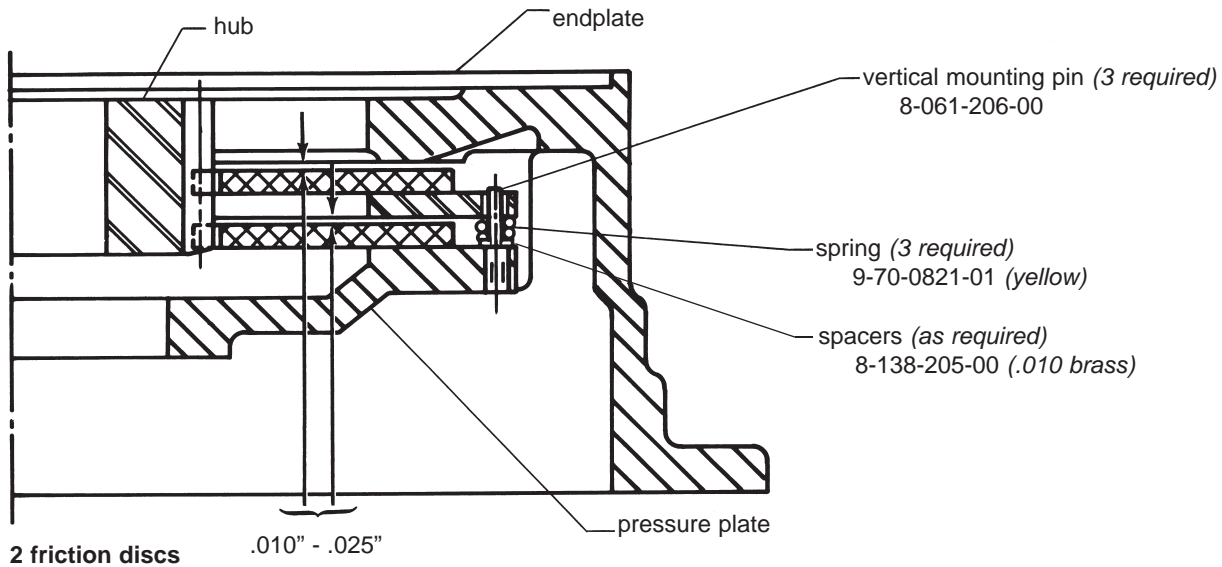

### Notes:

1. Follow Installation and Service Instruction Sheet No. 8-078-921-00 for assembly of brake to motor.
2. Assemble disc pack on bench using spacers as required to obtain clearance dimensions shown above. Compress disc pack to make sure that components slide freely over pins. If springs do not return components, pins may be bent and will have to be straightened. Friction discs must be free to rotate. Center and align friction discs, and assemble disc pack into endplate.

3. For part numbers of stationary disc and pressure plate, refer to Parts List No. 8-078-921-00, under vertical mounting below motor.
4. For brakes with yellow and green springs refer to service sheet 8-078-931-05.

**Caution!** Conversion from horizontal to vertical mounting should not be attempted in the field without consulting factory.

