

Service Instructions for Gasket and Seal Kit

Series 87,000 NEMA 4 Cast Iron or Aluminum Disc Brake (rev. B)

Item No.	Description of parts included in kit	Qty. per kit
2S	Endplate oil seal	1
7S	Housing seal	1
15B	Housing nut gasket	3
69	Housing to endplate gasket	1
2P	Endplate plug (aluminum only)	3
7G	Manual release gasket (aluminum only)	1

Important

Please read these instructions carefully before servicing your Stearns Brake. Failure to comply with these instructions could cause injury to personnel and/or damage to property if the brake is installed or operated incorrectly. For definition of limited warranty/liability, contact Rexnord Industries, Inc., Stearns Division, 5150 S. International Dr., Cudahy, Wisconsin 53110, (414) 272-1100.

Caution

1. Servicing shall be in compliance with applicable local safety codes including Occupational Safety and Health Act (OSHA). All wiring and electrical connections must comply with the National Electric Code (NEC) and local electric codes in effect.
2. To prevent an electrical hazard, disconnect power source before working on the brake. If power disconnect point is out of sight, lock disconnect in the *off* position and tag to prevent accidental application of power.
3. Be careful when touching the exterior of an operating brake. Allow sufficient time for the brake to cool before

disassembly. Surface may be hot enough to be painful or cause injury.

4. Do not operate brake with housing removed. All moving parts should be guarded.
5. After usage, the brake interior will contain burnt and degraded friction material dust. This dust must be removed before servicing or adjusting the brake.

DO NOT BLOW OFF DUST using an air hose. It is important to avoid dispersing dust into the air or inhaling it, as this may be dangerous to your health.

- a) Wear a filtered mask or a respirator while removing dust from the inside of a brake.
 - b) Use a vacuum cleaner or a soft brush to remove dust from the brake. When brushing, avoid causing the dust to become airborne. Collect the dust in a container, such as a bag, which can be sealed off.
6. Maintenance shall be performed only by qualified personnel familiar with the construction and operation of the brake.

7. For proper performance and operation, only genuine Stearns parts should be used for repairs and replacements.

Warning! Any mechanism or load held in position by the brake should be secured to prevent possible injury to personnel or damage to equipment before any disassembly of the brake is attempted or before the manual release knob or lever is operated on the brake.

Instructions

1. To replace the endplate oil seal (2S) and endplate plug (2P), use the following procedure.
 - a) Remove manual release knob (148), housing screws (15) and housing (7).
 - b) Depress solenoid plunger (29) and pull release rod (146) back to lock brake mechanism in manual released position or tie plunger to frame (79).
 - c) Remove entire support plate assembly (142) by *evenly* unscrewing screws (142S).

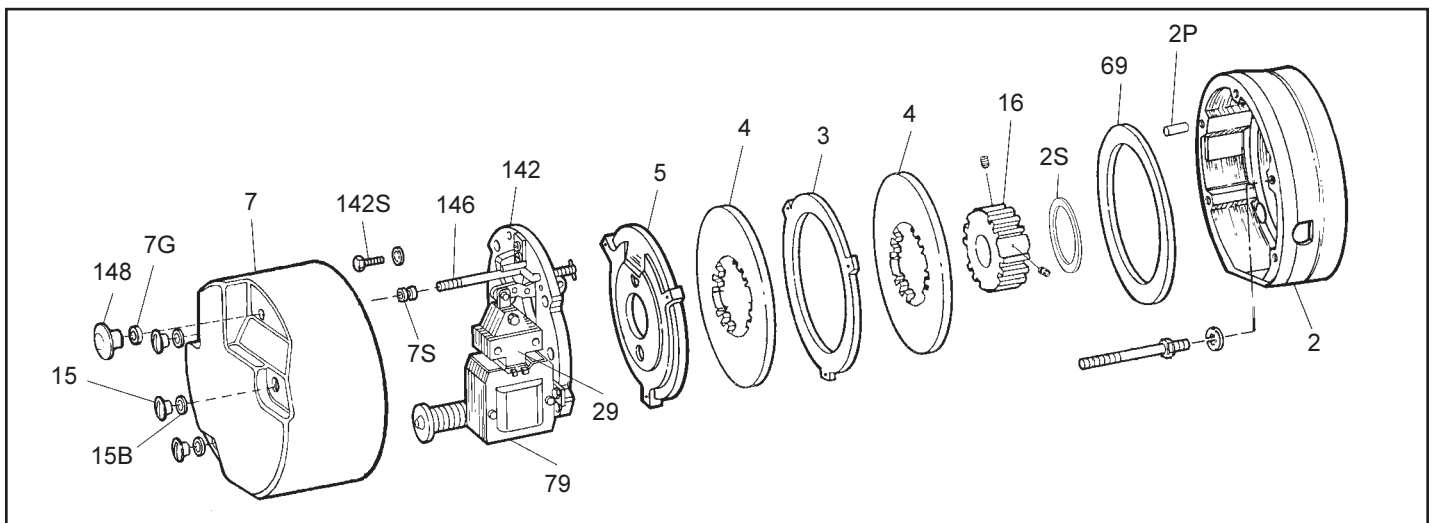

- d) Remove pressure plate (5), friction discs (4), and stationary discs (3).

Note: Brakes with a single friction disc will contain no stationary discs. Vertically mounted brakes will have special springs attached to the pressure plate/stationary disc(s). Note color coded sequence of springs, if used. Refer to Instruction Sheet P/N 8-078-937-06 for proper assembly of vertical mounting components.

- e) Remove hub (16) and endplate (2) from motor.
 - f) To replace endplate oil seal (2S), remove old seal from endplate (2) and install new seal from inboard face, be sure lip is toward inboard face and have seal face flush with face of casting.
 - g) To replace endplate plug (2P), remove plug (2P) from endplate (2), install from inboard face. The plug should be a tight press fit into the through hole.
2. The housing gasket (69) is placed over the register of endplate (2) for cast iron brake construction. For aluminum brake construction, the housing u-gasket is installed onto the sheet metal housing edge. Ends of u-gasket to meet.
 3. Gasket-housing nut (15B) is placed over the turned portion of the housing nut (15).
 4. Housing seal (7S) must be removed by pressing it out from the inboard housing face. The new seal is installed from the outboard housing face so that the lip points outward. Press the seal down into the counterbored hole until it seats on the counterbore face.

5. Reassemble the brake in the reverse order of Steps 4 through 1b and remove plunger tie-down, if used.
6. Manually lift solenoid plunger to maximum travel. Depress fully and allow solenoid plunger to snap out several times. Measure solenoid air gap between mating surfaces of solenoid frame and solenoid plunger. (On vertically mounted brakes, it will be necessary to push solenoid plunger into solenoid frame to the point where spring pressure is felt, before measuring solenoid air gap.) The solenoid air gap measurement should be as factory set between 13/16" to 15/16".
7. The solenoid air gap may be increased by raising or decreased by lowering the wrap spring stop (76). To accomplish this, loosen two stop screws (76S), move wrap spring stop slightly and retighten screws. Repeat Step 6 after each change in wrap spring stop position to obtain correct solenoid air gap measurement of 13/16" to 15/16".
8. Replace housing, screws and manual release knob.
9. **Caution!** Do not run motor with brake in manual release position. It is intended only for emergency manual movement of the driven load, not as a substitute for full electrical release.

NOTE: For complete instructions, with troubleshooting, request sheet applicable to the series of brake that you have.

