

Service Instructions for No. 8 Coil Kit Single and Dual Voltage Coils

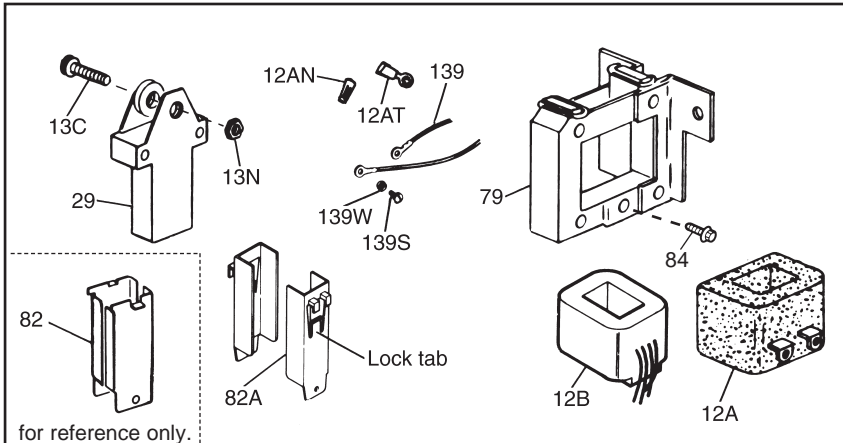

Item No.	Description of Parts Included in Kit	Qty. Per Kit
<i>Included in Class H coil kits only:</i>		
12A	Coil	1
12AN*	Wire nut	1
12AT*	Crimp terminal	2
139	Lead wire & terminal assembly	2
139S	Terminal screw	2
139W	Terminal lock washer	2
82A	Plunger guide	1
<i>Included in Class B coil kits only:</i>		
12B	Coil	1
82A	Plunger guide	1
84	Plunger guide screws	2
12AN*	Wire nut	2
*Dual voltage kits only.		

Important

Please read these instructions carefully before servicing your Stearns Brake. Failure to comply with these instructions could cause injury to personnel and/or damage to property if the brake is installed or operated incorrectly. For definition of limited warranty/liability, contact Rexnord Industries, LLC, Stearns Division, 5150 International Dr., Cudahy, Wisconsin 53110, (414) 272-1100.

Caution

1. Servicing shall be in compliance with applicable local safety codes including Occupational Safety and Health Act (OSHA). All wiring and electrical connections must comply with the National Electric Code (NEC) and local electric codes in effect.
2. To prevent an electrical hazard, disconnect power source before working on the brake. If power disconnect point is out of sight, lock disconnect in the off position and tag to prevent accidental application of power.
3. Be careful when touching the exterior of an operating brake. Allow sufficient time for the brake to cool before disassembly. Surface may be hot enough to be painful or cause injury.
4. Do not operate brake with housing removed. All moving parts should be guarded.
5. After usage, the brake interior will contain burnt and degraded friction material dust. This dust must be removed before servicing or adjusting the brake.

DO NOT BLOW OFF DUST using an air hose. It is important to avoid dispersing dust into the air or inhaling it, as this may be dangerous to your health.

- a) Wear a filtered mask or a respirator while removing dust from the inside of a brake.
 - b) Use a vacuum cleaner or a soft brush to remove dust from the brake. When brushing, avoid causing the dust to become airborne. Collect the dust in a container, such as a bag, which can be sealed off.
6. Maintenance shall be performed only by qualified personnel familiar with the construction and operation of the brake.
 7. For proper performance and operation, only genuine Stearns parts should be used for repairs and replacements.

Warning! Any mechanism or load held in position by the brake should be secured to prevent possible injury to personnel or damage to equipment before any disassembly of the brake is attempted or before the manual release knob or lever is operated on the brake.

Instructions

1. To remove housing, follow instructions listed under each individual brake series shown in illustration, then continue with the following steps.
2. To replace coil (12A) or (12B), disconnect lead wire terminal screws (139S), lock washers (139W) and lead wire and terminal assembly (139). It is *not* necessary to remove the support plate assembly (142).
3. To remove coil (12A) or (12B), it is necessary to detach the solenoid frame (79) from the support plate assembly. To do this, remove three mounting screws (132) and conical spring washers (132W). A hex key with shortened leg is helpful.

Note: On 87,700 series brakes, insert a screwdriver under solenoid frame and pry up to free it from a driv-lok pin.

87,000; 87,100; 87,400 and 87,600 series

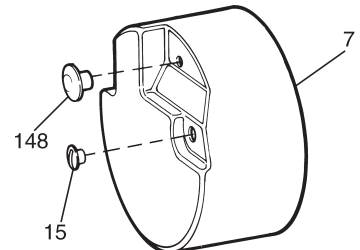

Remove manual release knob (148), two housing nuts (15), and housing (7) by pulling back.

87,200 series

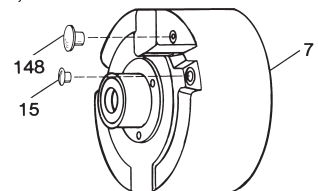

- a) Remove any accessories, sprockets, sheaves, etc. and bearing lock collar on standard enclosure brake from brake shaft on housing side.
- b) Remove manual release knob (148), two housing nuts (15), and housing (7) by pulling back

87,700 series

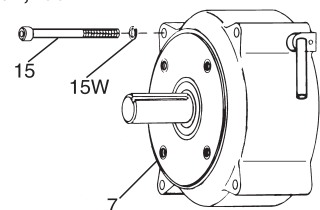

- a) Remove the brake and motor as a unit from the gear reducer.
- b) Remove four housing cap screws (15), lock washers (15W), housing (7) and shaft assembly.

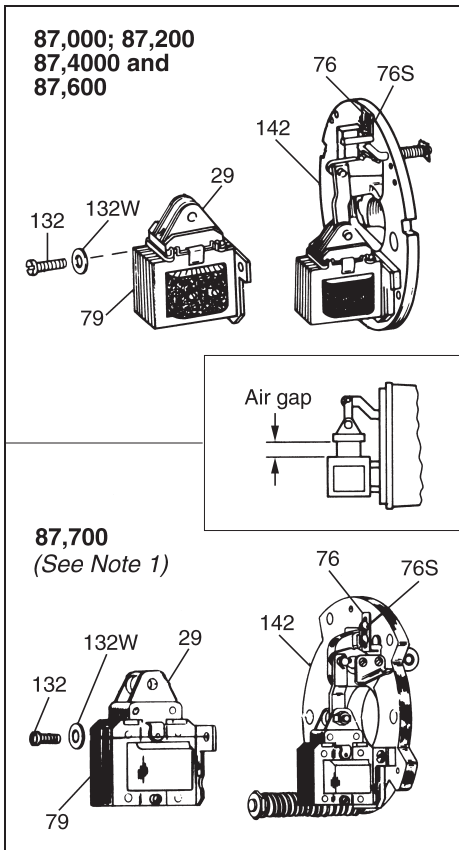

4. For metallic plunger guides (82) remove plunger guide screw(s) (84) and lock washer(s) (84W) if used. Insert shim stock or other thin gauge material at top center of coil between coil and solenoid frame. Push to release lock tab while lifting up on plunger guide. Repeat for other plunger guide.

a) To remove non-metallic plunger guides (82A) remove screw(s) (84) and lock washer(s) (84W) if used. Insert shim stock or other thin gauge material at top center of coil between coil and solenoid frame. Push to release lock tab while lifting up on plunger guide. Repeat for other plunger guide.

Note: Metallic plunger guides have been replaced by non-metallic guides in the class "H" applications.

5. Slide coil (12A) or (12B) out from solenoid frame (79) in the direction of the coil leads or terminals. If necessary tap coil lightly with a soft hammer. If solenoid coil had burned out, be sure to remove all foreign material from the solenoid plunger (29) and solenoid frame.

6. Install new coil (12A) or (12B) into solenoid frame with same relative position as old coil. Assemble new non-

metallic plunger guides (82A), (Guide screws are no longer required with plastic guides).

Note 1: 87,700 no. 8 coil lead wires must be to the inside of the brake.

a) Assemble new non-metallic plunger guides (82A) by inserting into position and pushing down until lock tab snaps under top bar of solenoid frame.

Note 2: For coils with terminals, check that lock tab face is flush with inside surface of guide. If not, file chamfer (about 1/16" by 45°) on coil at lock tab areas.

Install self-tapping plunger guide locking screws (84) through the bottom hole of each guide.

7. Slide solenoid frame with the installed coil over solenoid plunger (29) and attach to support plate assembly (142) with three mounting screws (132) and conical spring washers (132W). Before tightening mounting screws, align solenoid plunger and solenoid frame so that mating surfaces are parallel. This can be accomplished by manually pulling the plunger down into its sealed position.

Note 3: On 87,700 series brakes (prev only), align hole for driv-lok pin engagement with the hole. If pin does not engage, it will be necessary to remove the support plate and force pin into the hole, then reinstall.

8. Torque the three mounting screws (132) with conical spring washers (132W) to 75-78 in-lbs.

9. Dual voltage class H (encapsulated) coils have two terminals and two black wires. Dual voltage class B (molded) coils have two red and two black wires. follow proper leadwire sequence.

10. Be sure lead wires to coil are not tight or pinched; leads must not be rubbed by friction disc; leads must not be trapped between solenoid plunger and frame.

11. Manually lift solenoid plunger to maximum travel. Depress fully and allow solenoid plunger to snap out several times. Measure solenoid air gap between mating surfaces of solenoid frame and solenoid plunger. (On vertically mounted brakes, it will be necessary to push solenoid plunger into solenoid frame to the point where spring pressure is felt, before measuring solenoid air gap.) The solenoid air gap measurement

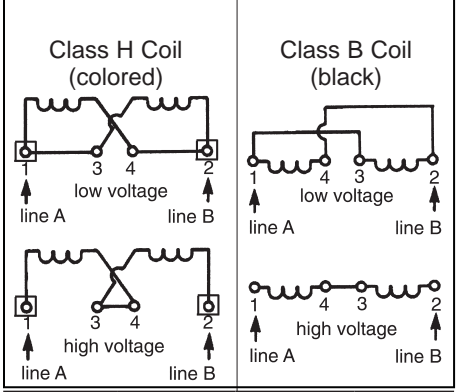
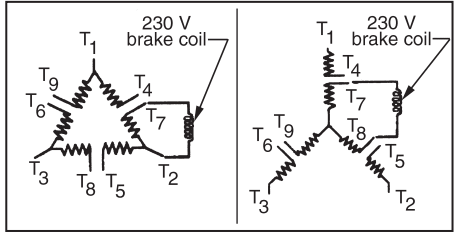

For	Power Line A	Power Line B	Tie Leads
Low voltage	1 and 3	2 and 4	---
High voltage	1	2	3 and 4

12. The solenoid air gap may be increased by raising or decreased by lowering the wrap spring stop (76). To accomplish this, loosen two stop screws (76S), move wrap spring stop slightly and retighten screws. Repeat Step 11 after each change in wrap spring stop position to obtain correct solenoid air gap measurement of 13/16" to 15/16".

13. Reconnect coil leads.

14. Replace housing, screws and manual release knob in the reverse order of the appropriate point in Step 1.

15. **Caution 1!** Do not run motor with brake in manual release position. It is intended only for emergency manual movement of the driven load, not as a substitute for full electrical release.

Caution 2! Class H coils with terminals. Do not bend lead wire crimp connection as this causes fatigue in the metal which may break under vibration.

NOTE: For complete instructions, with troubleshooting, request sheet applicable to the series of brake that you have.