

Service Instructions for No. 5, 6 & 8 AC Solenoid Assembly Series 57,000; 67,000 and 77,000 Disc Brakes

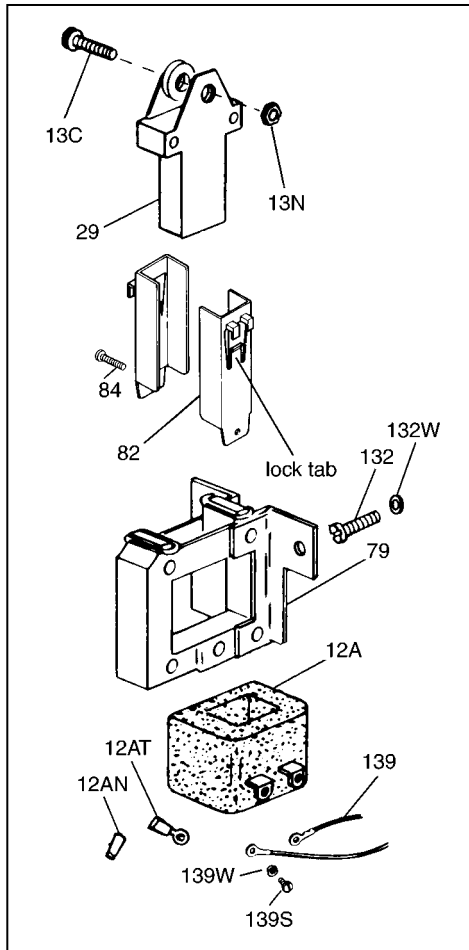

Item No.	Item Description	Qty.
29	Solenoid plunger	1
79	Solenoid frame	1
132W	Solenoid mounting lock washer	3
132*	Solenoid mounting screw	1
132	Solenoid mounting screw	3

*For 57,000 Series only 3/8" long.

Important

Please read these instructions carefully before servicing your Stearns brake. Failure to comply with these instructions could cause injury to personnel and/or damage to property if the brake is serviced or operated incorrectly. For definition of limited warranty/liability, contact Rexnord Industries, Inc., Stearns Division, 5150 S. International Dr., Cudahy, Wisconsin 53110, (414) 272-1100.

Caution

1. Servicing shall be in compliance with applicable local safety codes including Occupational Safety and Health Act

(OSHA). All wiring and electrical connections must comply with the National Electric Code (NEC) and local electric codes in effect.

2. To prevent an electrical hazard, disconnect power source before working on the brake. If power disconnect point is out of sight, lock disconnect in the *off* position and tag to prevent accidental application of power.
3. Be careful when touching the exterior of an operating brake. Allow sufficient time for the brake to cool before disassembly. Surface may be hot enough to be painful or cause injury.
4. Do not operate brake with housing removed. All moving parts should be guarded.
5. After usage, the brake interior will contain burnt and degraded friction material dust. This dust must be removed before servicing or adjusting the brake.

DO NOT BLOW OFF DUST using an air hose. It is important to avoid dispersing dust into the air or inhaling it, as this may be dangerous to your health.

- a) Wear a filtered mask or a respirator while removing dust from the inside of a brake.
 - b) Use a vacuum cleaner or a soft brush to remove dust from the brake. When brushing, avoid causing the dust to become airborne. Collect the dust in a container, such as a bag, which can be sealed off.
6. Maintenance should be performed only by qualified personnel familiar with the construction and operation of the brake.
 7. For proper performance and operation, only genuine Stearns parts should be used for repairs and replacements.

Warning! Any mechanism or load held in position by the brake should be secured to prevent possible injury to personnel or damage to equipment before any disassembly of the brake is attempted or before the manual release knob or lever is operated on the brake.

Instructions

1. To remove housing, follow instructions listed under each individual brake series in Figure 2, then continue with the following steps.
2. Solenoid replacement can be accomplished without removing the support plate from brake.

3. Disconnect coil lead wires. Remove three solenoid mounting screws (132) and lock washers (132W) to free solenoid frame (79).
4. Disconnect solenoid plunger (29) and solenoid link (13) as follows:
 - a) On the 57,000 Series of 67,000 and 77,000 Series with No. 5 or No. 6 solenoids, remove cap screw (13C) and nut (13N). Save for reuse later.
 - b) On the 67,000 and 77,000 Series with No. 8 solenoid, remove one of two cotter pins (13CP) and straight pin (13P). Save pin (13P) for reuse later.

57,000 Series

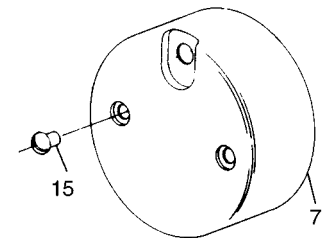

Remove two housing nuts (15) and housing (7) by pulling back.

67,000 Series

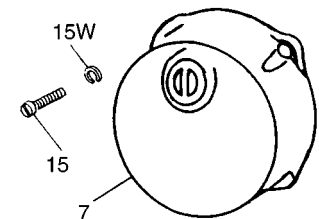

Remove four housing cap screws (15), lock washers (15W) and housing (7) by pulling back.

77,000 Series

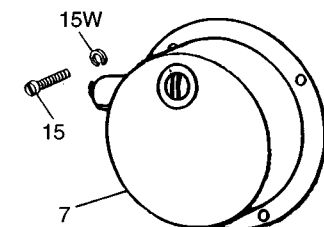

Remove four housing cap screws (15), lock washers (15W) and housing (7) by pulling back.

Figure 2

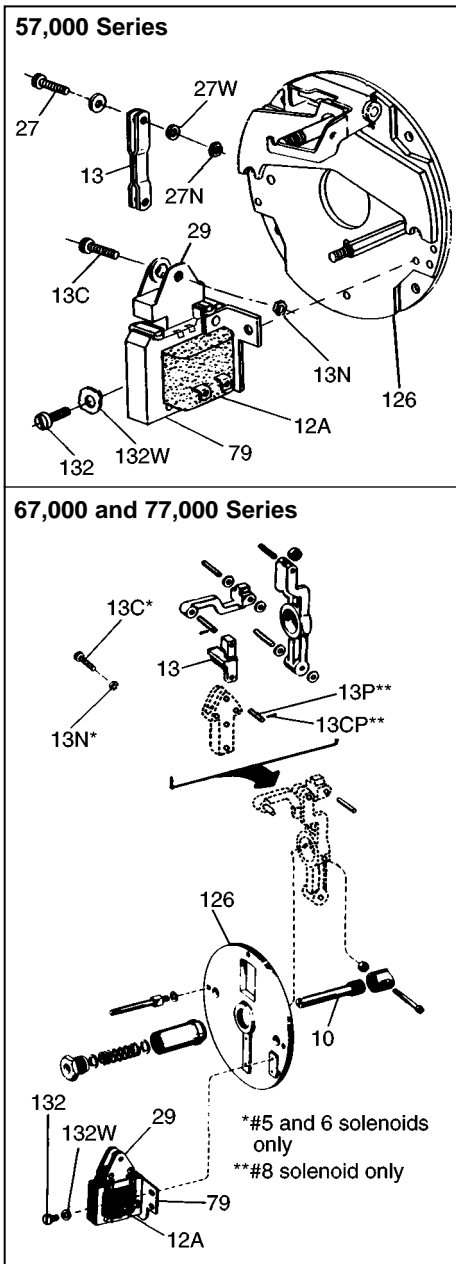

Figure 3

5. For metallic plunger guides (82) remove plunger guide screw (84). Remove both plunger guides (82) by prying up on the flanges.
To remove non-metallic plunger guides (82), remove screw (84) and lock washer (84W). Insert shim stock or other thin gauge material at top center of coil between coil and solenoid frame. Push to release lock tab while lifting up on plunger guide. Repeat for other guide.
6. Slide coil (12A) out from solenoid frame (79) in the direction of the coil terminals. If necessary, tap coil lightly with a soft hammer. If solenoid coil had burned out, be sure to remove all foreign material from the plunger guides.

7. Install new coil (12A) into solenoid frame with same relative position as old coil.

Assemble new non-metallic plunger guides (82) by inserting into position and pushing down until lock tab snaps under top bar of solenoid frame. Install plunger guide screw and lock washer. With encapsulated coils (with terminals) check that lock tabs allow free movement of plunger. If movement is restricted, file chamfer on coil at lock tab areas.

8. a) On the 57,000 Series, or 67,000 and 77,000 Series with No. 5 and No. 6 solenoids, install new plunger (29) to link (13) in reverse order of Step 4, Item a.
b) On the 67,000 and 77,000 Series with No. 8 solenoid, install new plunger (29) to link (13) in reverse order of Step 4, Item b. Use new cotter pin (not supplied).
9. Slide solenoid frame (79) over new plunger (29). Attach to support plate (126) with three new mounting screws (132) and lock washers (132W). Note that on the 57,000 brake there is a 10-24 x 3/8" long fillister head screw required to mount the upper left hand flange of solenoid. This screw is provided in the assembly packet.

Before tightening mounting screws, align the plunger and frame so that mating surfaces are parallel. Manually pulling the plunger (29) down into the sealed position will help with alignment. (If later there is a solenoid buzz upon energization, then a slight realignment may be necessary).

10. Manually lift solenoid plunger to maximum travel. Depress and allow solenoid plunger to snap out several times. Measure solenoid air gap between mating surfaces of solenoid and solenoid plunger. (On vertically mounted brakes, it will be necessary to push solenoid plunger into solenoid frame to the point where spring pressure is felt, before measuring solenoid air gap). The correct solenoid air gap measurements are shown in Table.
11. Solenoid gap adjustment:
 - a) **57,000 Series**
When gap reaches 3/4" to 7/8" brake must be adjusted. Turn both wear adjustment nuts (10) equal amounts in clockwise direction (one half turn at a time) until gap is 1/2" to 5/8". The screwdriver slots in both adjustment nuts must always be on the horizontal centerline (Figure 4) to permit full bearing of pressure contact points.

Table: Solenoid Air Gap Measurement (in.)

Nominal Static Torque (lb-ft)	57,000 Series	67,000 Series	77,000 Series
6	1/2-5/8	—	—
10	1/2-5/8	7/16	7/16
15	1/2-5/8	7/16	7/16
25	—	7/16	7/16
35	—	9/16	9/16
50	—	9/16	9/16
75	—	5/8	5/8
105	—	5/8	5/8

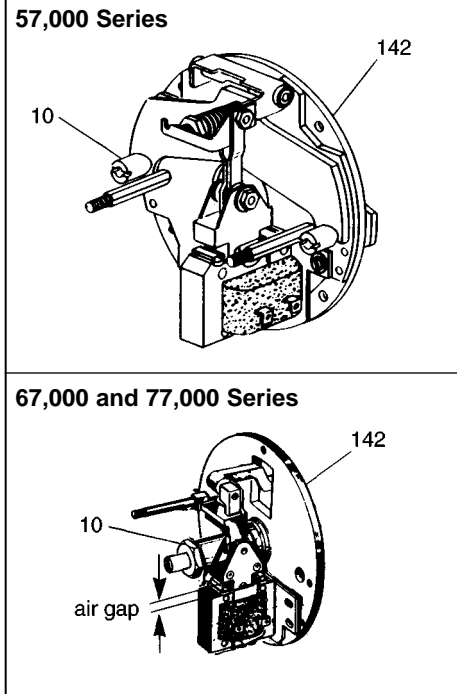

- b) **67,000 and 77,000 Series**
Insert screwdriver and turn adjusting stud (10) counterclockwise until proper solenoid gap is attained. (See Table and Step 10).
12. Reconnect coil leads.
13. Replace housing and housing nuts or bolts in reverse order of the appropriate point in Step 1.
14. **Caution!** Do not run motor with brake in manual release position. It is intended only for emergency manual movement of the driven load, not as a substitute for full electrical release.

NOTE: For complete instructions, with troubleshooting, request sheet applicable to the series of brake that you have.