

Performance Parameters & Limited Warranty

“Seller” and/or “Stearns” refers to Rexnord Industries, LLC (which sells products and services under the Stearns brand) for the entirety of this catalog, warranty, products, and services.

The performance of Stearns brakes, clutches, clutch-brake combinations, solenoids, and controls depends upon the proper application of the product, adequate run in, installation and maintenance procedures, and reasonable care in operation.

All torque values listed in our bulletins are nominal and are subject to the variations normally associated with friction devices. The purchaser should take into consideration all variables shown in the applicable specification sheets. Although our application engineers are available for consultation, final selection and performance assurance on the purchaser’s machine is the responsibility of the purchaser. Careful purchaser selection, adequate testing at time of installation, operation and maintenance of all products of the seller are required to obtain effective performance.

Stearns warrants to its purchasers that all its products will be free from defects in material and workmanship at the time of shipment to the purchaser for a period of one (1) year from the date of shipment. All warranty claims must be submitted in writing to Stearns within the warranty period, or shall be deemed waived. As to products or parts thereof which Stearns finds to have been defective at the time of shipment, its sole responsibility hereunder shall be to repair, correct or replace (whichever Stearns deems advisable) such defective products or parts without charge, FOB Stearns factory. In the alternative, Stearns may, at its option, either before or after attempting a different remedy, refund the purchase price upon return of the product or parts.

This warranty shall not apply to any product which has been subjected to misuse: misapplication: neglect (including but not limited to improper maintenance and storage); accident: improper installation; modification (including but not limited to use of other than genuine Stearns replacement parts or attachments); adjustment; or repair.

THE FOREGOING IS IN LIEU OF ALL OTHER WARRANTIES, WHETHER EXPRESSED, IMPLIED, OR STATUTORY, INCLUDING THAT OF MERCHANTABILITY AND OF FITNESS FOR A PARTICULAR PURPOSE, AND OF ANY OTHER OBLIGATION OR LIABILITY ON OUR PART OF ANY KIND OR NATURE WHATSOEVER.

No Stearns representative has any authority to waive, alter, vary or add to the terms hereof without prior approval in writing, to our purchaser, signed by an officer of the seller.

Stearns liability for its products, whether for breach of contract, negligence, strict liability in tort, or otherwise, shall be limited to the repair, correction, or replacement of the products or parts thereof, or to the refund of the purchase price of such products or parts. Stearns will not be liable for any other injury, loss, damage or expense, whether direct or consequential, including but not limited to loss of use, income, profit or production, or increased cost of operation, or spoilage of or damage to material, arising in connection with the sale, installation, use of, inability to use, or the repair or replacement of, or late delivery of, Stearns products.

Any cause of action for breach of the foregoing warranty must be brought within one (1) year from the date the alleged breach occurs.

Note on Special Applications:

Stearns products are designed for standard industrial and commercial applications. Operating requirements, environments and required tolerances such as in nuclear and aircraft applications may be beyond the commercial standards of the Stearns Divisions products. Stearns will assume absolutely no responsibility for the use of and/or resale of Stearns products for such applications unless approved in writing in advance by Stearns.

View the most up-to-date terms and conditions at www.regalrexnord.com/terms-and-conditions-of-sale.

Introduction to Solenoid Actuated Brakes (SAB)

Stearns solenoid actuated brakes (SAB) are a electromechanical braking system that functions via a spring-setting action that defaults to an engaged “safe” state. Stearns offers the most comprehensive line of SABs on the market today. We earned our reputation as the industry’s quality leader by working closely with you, our customers, understanding your needs and developing products with features to handle your most challenging applications. We have installed millions of Stearns brakes worldwide since 1935.

The compact design delivers high torque in a small size with fast, positive response and no residual drag when released. Our brakes can be mounted directly onto any NEMA C-face surface without special alignment procedures and feature unitized construction which makes servicing friction discs easy using only a screwdriver and wrench. Stearns SABs ensure automatic stopping and holding any time power to the brake is interrupted.

IP Ratings

Stearns brakes have various IP ratings when properly installed. Brake modifications and customer-installed accessories may change rating.

IP 20: Protected against a solid object greater than 12.5mm, such as a finger.

IP 21: Previous IP coverage plus protection against vertically falling drops of water. Limited ingress permitted.

IP 23: Previous IP coverage plus protection against sprays of water up to 60 degrees from the vertical. Limited ingress permitted for three minutes.

IP 40: Protection against a solid object greater than 1mm, such as a wire.

IP 54: Previous IP coverage plus dust protection. Limited ingress of dust permitted. Will not interfere with operation of the equipment for two to eight hours. Protected against water splashed from all directions. Limited ingress permitted.

IP 55: Previous IP coverage plus protection against jets of water. Limited ingress permitted.

IP 56: Previous IP coverage plus protection against water from heavy seas or water projected in powerful jets. Water shall not enter the enclosure in harmful quantities.

IP 57: Previous IP coverage plus protection against the effects of immersion in water between 15cm and 1m for 30 minutes.

Enclosure Types

Stearns SABs are certified to meet or exceed UL standards and can have various NEMA ratings.

UL Type 1: Indoor use to provide a degree of protection to personnel against access to hazardous parts and the ingress of solid foreign objects (falling dirt).

UL Type 4: Indoor or outdoor use to provide a degree of protection against ingress of solid foreign objects (falling dirt, windblown dust) and water (rain, sleet, snow, splashing water, hose-directed water); will be undamaged by the external formation of ice on the enclosure.

UL Type 4X: Indoor or outdoor use to provide a degree of protection against ingress of solid foreign objects (falling dirt, windblown dust) and water (rain, sleet, snow, splashing water, hose-directed water); will be undamaged by the external formation of ice on the enclosure; increased protection against corrosion.

NEMA 7: Designed to contain an internal explosion without causing an external hazard.

NEMA 9: Designed to prevent the ignition of combustible dust.

Self-Adjusting Disc Brakes

Inaccessible locations or high cycling applications require a specially designed, low-maintenance brake that will operate at peak efficiency and provide uniform braking for long periods of time. Stearns exclusive self-adjusting feature eliminates the major cause of brake maintenance: friction lining wear. Self-adjusting brakes are also well suited for applications where rapid cycling requires frequent resetting of solenoid air gap. Automatic adjustment also eliminates errors that can occur with hand adjustment.



Manually Adjusted Disc Brakes with Auto Reset

Standard features include a unique spring design which allows for universal mounting; an air gap adjustment gauge for visual recognition that the brake needs adjustment; a patented hub design; and genuine Stearns friction discs which are trademarked and patented. Different housing, endplate and release configurations, with a wide variety of pre-engineered modifications, allow for virtually unlimited possible combinations.



Introduction to Stearns Solenoid Actuated Brakes (SAB)

Brakes for Hazardous Locations

Stearns manufactures a complete line of brakes designed for hazardous locations. Each brake is labeled to show the Class, Group, and maximum operating temperature of the brake enclosure. We offer both motor-mounted and foot-mounted designs, and all Stearns hazardous location brakes are UL Listed (cULus).

Double C-Face Disc Brake Couplers

Stearns disc brake couplers provide maximum versatility, allowing you to add a brake to a C-face motor with a single shaft extension. Using these reliable products, you can couple a C-face motor to a C-face gear reducer.



Trademarked & Patented Friction Discs

Now you can rely on identifying genuine Stearns friction discs which assure continuous, reliable performance backed by the Stearns name. A molded ring in the Stearns friction discs makes it easy to visually identify a Stearns disc. The splined discs are trademarked and patented by Stearns.

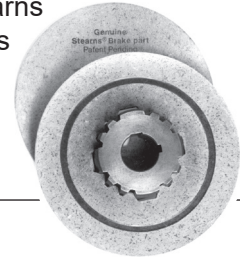

Marine Applications

Brakes used in marine applications are customized to meet specific standards. These standards are established to provide various levels of corrosion resistance and performance standards under specific conditions.

Maritime & Naval Brakes

Designed for U.S. Navy and Coast Guard military specifications. These units conform to MIL-B-16392C or 46CFR 110.10-1 and IEEE

Standard 45. Special material components help prevent corrosion due to shipboard environments. SABs used in marine environments can be custom built to meet the specifications. All Stearns SABs

can be "Type Approval Certified" by the American Bureau of Shipping.



Comparing SABs vs. IEC Models

Solenoid Actuated Brakes	IEC Models
Simple wear adjustment	Complex wear adjustment
Easy coil exchange for different voltages	Difficult to change out complete magnet assembly
Maintained manual release with automatic reset for brake release during set-up	Non-maintained release (deadman) requires constant external force to operate
Add on options easily assembled to standard unit	Options require complete brake in most units
Rapid set and release times	Response time is slower due to required magnetic field build-up in magnet-style coil
Connection can be made directly to AC power source	Direct connection to AC power source requires an optional electric control

Manually Adjusted Solenoid Actuated Brakes

Stearns manually-adjusted disc brakes are available from 1.5 to 105 lb-ft static torque. They feature spring-set, electrically released designs having simple adjustments to compensate for friction lining wear. All have 2-wire motor connection.

Series 48,100 Disc Brakes

Mount directly to NEMA 48C motor frames. Static torque ratings are 1.5, 3 and 6 lb-ft.

Quality Design Features:

- Spring-set, electrically released
- Single-disc caliper design
- Simple wear adjustment for easy maintenance
- Knock-out plug on housing for through-shaft applications
- Maintained manual release with automatic reset
- Mount in any position without modification

All Series 56,X00 Disc Brakes

Mount directly to NEMA 56C, 143TC, 145TC, 182TC and 184TC motor frames. Static torque ratings from 1.5 to 25 lb-ft.

The 56 Series family is a comprehensive line of spring-set brakes that set new standards for quality, reliability and customer convenience. Here's a sampling of the features we've built into the Stearns 56 Series brakes:

- A Stearns-exclusive spring design permits all-position mount for unlimited mounting possibilities.
- Trademarked and patented friction discs
- Patented splined hub that increases friction disc working area, runs quieter, and offers enhanced heat dissipating capability
- ABS Type Approval Certified

The 56 Series come in static torque ratings from 1.5 through 25 lb-ft with NEMA C-face mountings 56C, 143TC, 145TC, 182TFC, and 184TFC. With a wide variety of pre-engineered modifications, you can select from 120,000 possible combinations!

87,000 Series Disc Brakes

An optional manual adjust mechanism can be provided on 87,000 Series brakes (does not include 87,300 and 87,800 Series brakes). Mounted directly to NEMA 182TC through 256TC frames. Includes all the other features of the Series 87,000.

Series 56,000 Design Features

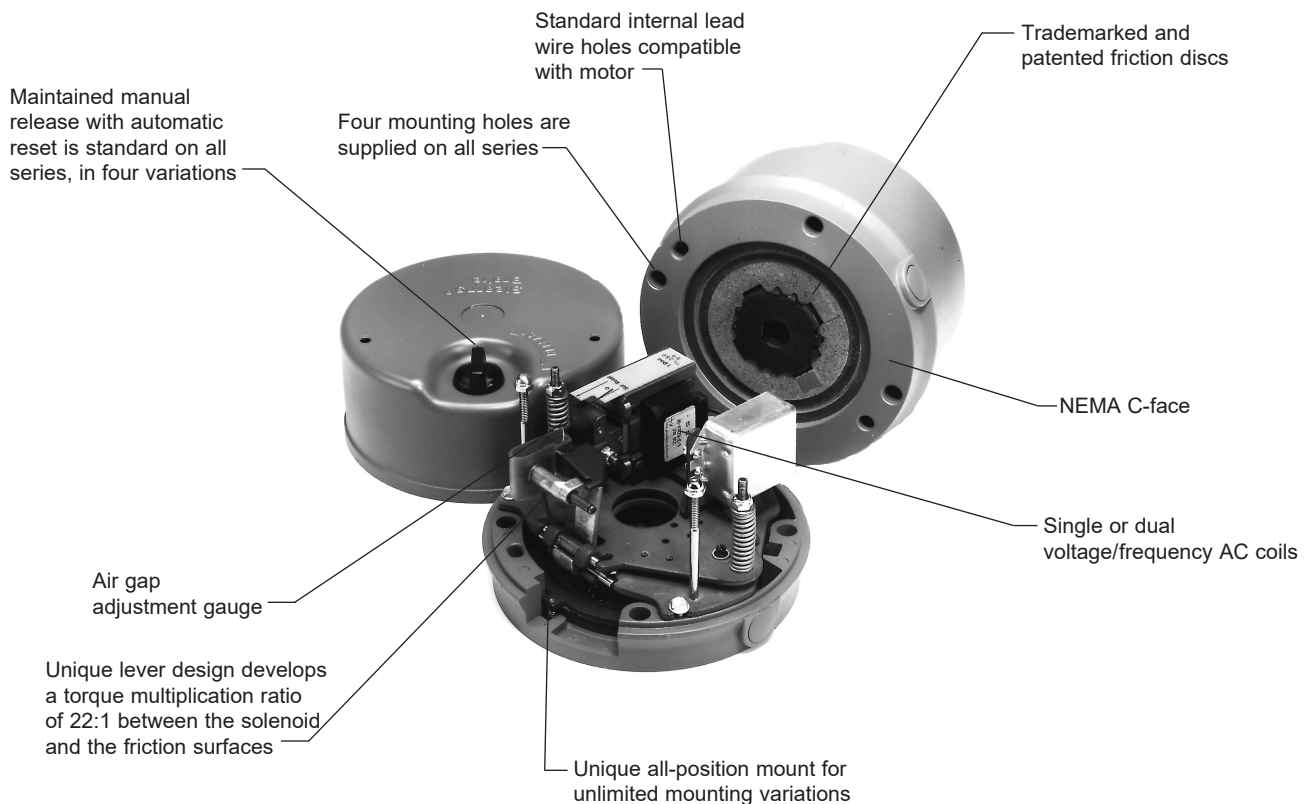

Self-Adjusting Solenoid Actuated Brakes

Stearns self-adjusting disc brakes feature an exclusive, automatic adjusting device that eliminates the major cause of brake maintenance – friction lining wear. This feature is ideal for remote or inaccessible locations or applications where rapid cycling requires frequent wear adjustment.

The self-adjust mechanism is a simple wrap-spring clutch that automatically adjusts the brake's solenoid air gap to compensate for wear of the friction discs. Automatic adjustment occurs every time the brake functions meaning every operation is at peak efficiency, providing more uniform braking, longer disc life, less maintenance time and smooth, quiet operation.

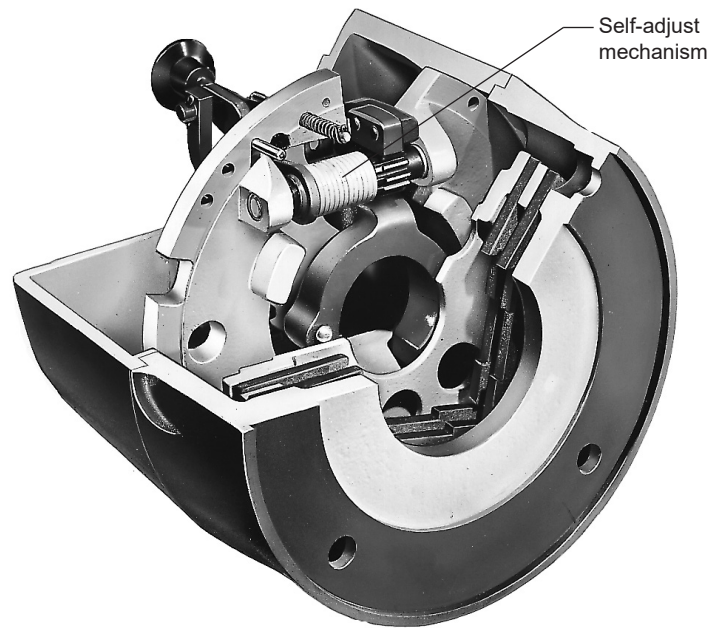

There are nine series of Stearns self-adjusting brakes to select from:

- Series 81,000 brakes for direct mounting to NEMA 324TC through 365TC motor frames. Static torque ratings from 125 to 230 lb-ft.
- Series 82,000 brakes for direct mounting to NEMA 324TC through 405TSC motor frames. Static torque ratings from 125 to 440 lb-ft.
- Series 86,X00 brakes for direct mounting to NEMA 444TSC through 505TSC motor frames. Static torque ratings from 500 to 1,000 lb-ft.
- Series 87,X00 brakes for direct mounting to NEMA 182TC through 286TC motor frames. Static torque ratings from 6 to 125 lb-ft.
- Series 87,200 for floor mounted, double shaft output with bearing support. Static torque ratings from 10 to 105 lb-ft.
- Series 87,300 hazardous location brakes for UL Listed Division I applications, which mount directly to NEMA 182TC through 256TC motor frames. Static torque ratings from 10 to 105 lb-ft.
- Series 82,300 hazardous location brakes for UL Listed Division I applications, for mounting directly to NEMA 324TC through 405TSC. Static torque ratings 125 to 330 lb-ft.
- Series 87,700 brakes for in-line applications, to couple the motor and gear box. For direct mounting to NEMA 182TC through 256TC motor frames. Torque rating of 10 to 105 lb-ft.
- Series 87,800 brakes hazardous location brake for UL Listed Division 2 applications, which mount directly to NEMA 182TC through 256TC motor frames. Static torque ratings of 6 to 105 lb-ft.

Quality Design Features

- Spring-set, electrically released
- Self-adjusting mechanism minimizes maintenance by automatically compensating for lining wear
- Unitized construction for easy friction disc replacement
- Maintained manual release with automatic reset
- Simple 2-wire motor connection
- Standard or dust-tight, waterproof enclosures available
- Many modifications for special application requirements
- Models for marine & maritime applications
- Models in accordance with Military Specification B16392-C for Navy applications
- ABS Type Approval Certified

Lever Arm & Self-Adjusting Mechanism

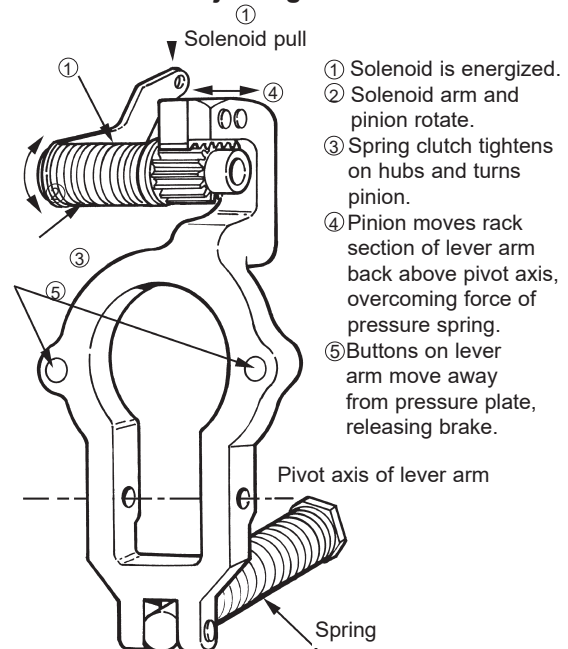

Exploded View & Part Identification

56,000 Series Manually-Adjusted Solenoid Actuated Brake

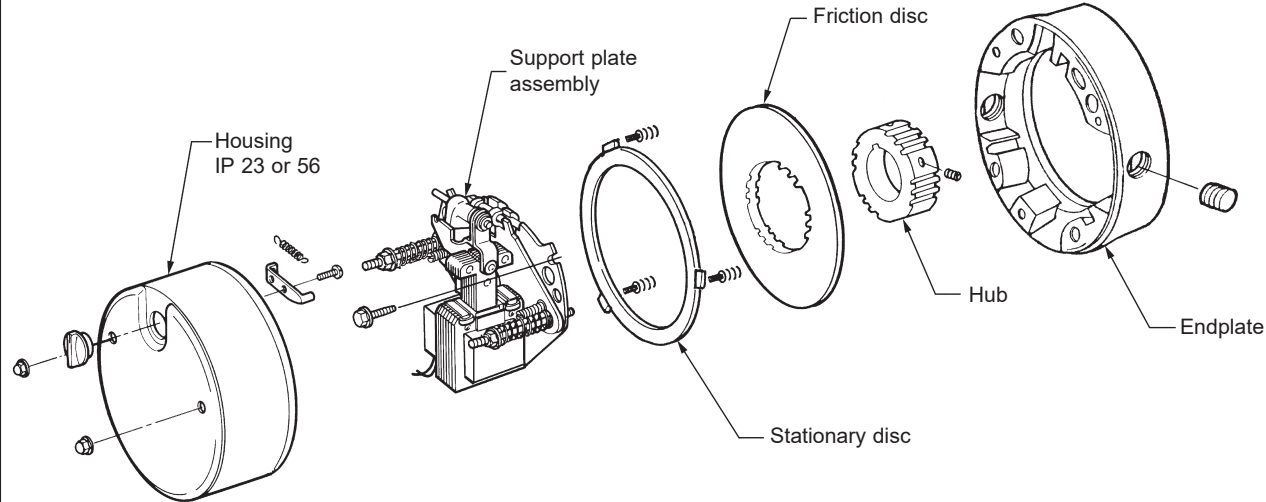

Main Components of a Self-Adjusting Disc Brake

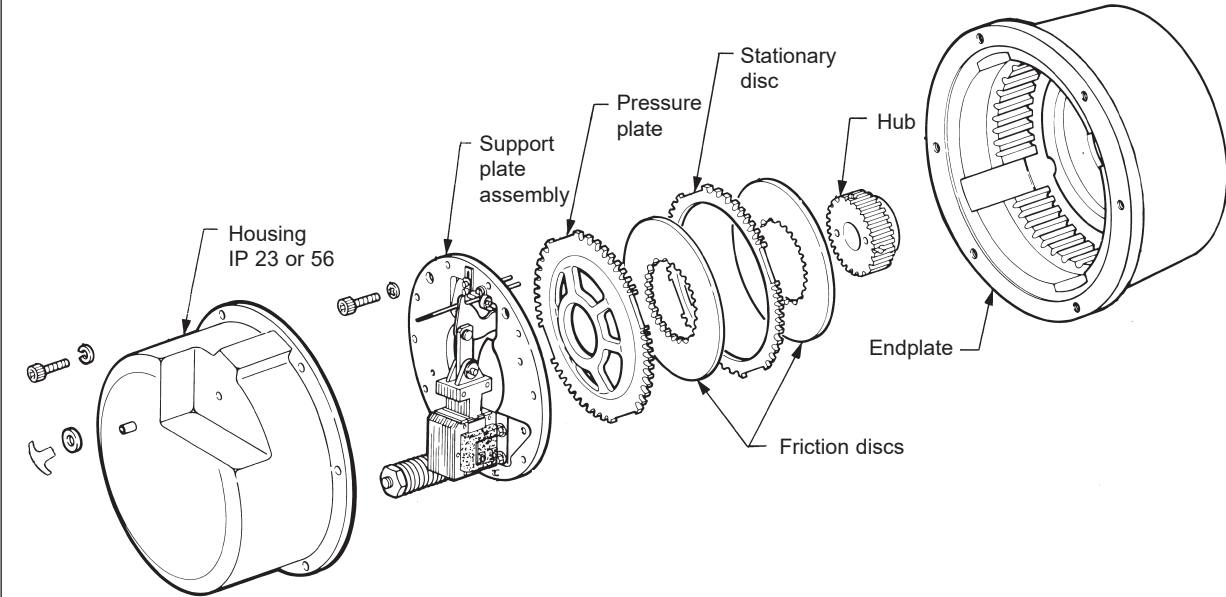

SELECTION - Solenoid Actuated Brakes

NOTE: For overhauling/high inertia loads, to stop in a specified time/distance, or for brakes combined with variable frequency drives, please refer to the application engineering section.

Stearns solenoid actuated brakes can be easily selected from Table 1 and 2.

Given motor data:

1. Horsepower (hp)
2. Speed (RPM)
3. NEMA C-face frame size

Determine:

1. Static torque rating of the brake (lb-ft)
2. Brake series

Step 1 – Given the motor horsepower and speed, select the brake torque from Table 1. Torque in table 1 is calculated using formula:

$$T_s = \frac{5,252 \times P}{N} \times SF$$

Where, T_s = Static torque, lb-ft

P = Motor horsepower, hp

N = Motor full load speed, rpm

SF = Service Factor

5,252 = constant

Example: Given a 5 hp, 1800 RPM motor, the selected brake is 20 or 25 lb-ft.

Step 2 – Given the NEMA C-face motor frame size, select the brake series from Table 2.

Example: Given the 5 hp, 1800 RPM motor in Step 1 with a NEMA 184TC frame, Series 87,000; 87,300 or 87,700 brakes can be selected to mount directly to the motor.

Table 1 – Torque Selection

In this table, brake torque ratings are no less than 140% of the motor full load torque.

Motor hp	Brakemotor Shaft Speed (RPM)						
	700	900	1200	1500	1800	3000	3600
	Static Torque Rating of Brake (lb-ft)						
1/6	3	1.5	1.5	1.5	0.75	0.5	0.5
1/4	3	3	3	1.5	1.5	0.75	0.5
1/3	6	3	3	3	1.5	1.5	0.75
1/2	6	6	3	3	3	1.5	1.5
3/4	10	6	6	6	6	3	3
1	15	10	6	6	6	3	3
1-1/2	20	15	10	10	10	6	3
2	25	20	15	10	10	6	6
3	35	25	20	15	15	10	6
5	75	50	35	25	20 or 25	15	10
7-1/2	105	75	50	50	35	25	15
10	105	105	75	50	50	25	25
15	175	125	105	75	75	50	35
20	230	175	125	105	105	50	50
25	330	230	175	125	105	75	50
30	330	330	230	175	125	75	75
40	440	330	330	230	175	105	105
50	550	440	330	330	230	*	*
60	750	500	440	330	330	*	*
75	1000	750	500	440	330	*	*
100	—	1000	1000	500	440	*	*
125	—	—	1000	750	500	*	*
150	—	—	—	750	750	*	*
200	—	—	—	1000	1000	*	*
250	—	—	—	—	1000	*	*

*See catalog pages for maximum rpm by series. Thermal capacity must be considered in load stops over 1800 rpm.

Table 2 – Brake Series Selection by NEMA Frame Size

Torque Range (lb-ft)	Brake Series	C-Face Motor Frame Size											
		48C	56C	143TC 145TC	182TC 184TC	213TC 215TC	254TC 254UC 256TC 256UC	284TC 284UC 286TC 286UC	324TC 324UC 326TC 326UC	364TC 364UC 365TC 365UC	404TC 404UC 405TC 405UC	444TC 444UC 445TC 445UC	504UC 504SC 505C 505SC
Manually-Adjusted Brakes (require periodic adjustment to compensate for friction disc wear)													
1.5-6	48,100	①											
1.5-25	56,000		①	①	②	②	②						
10-25	56,500				①	②	②						
Self-Adjusting Brakes (automatically compensate for friction disc wear)													
6-105	87,000		③	③	①	①	①	②	②	②	②		
50-105	87,100							①	②	②	②		
125-230	81,000				②	②	②	②	①	①	①	②	
125-440	82,000				②	②	②	②	①	①	①	②	
500-1000	86,000							②	②	②	②	①	
500-1000	86,100												①
Division 1 Hazardous Location Brakes (for atmospheres containing explosive gases or ignitable dusts) / Motor Mounted													
1.5-15	65,300		①	①	②	②	②						
10-105	87,300				①	①	①	②	②	②	②		
125-330	82,300				②	②	②	②	①	①	①	②	
Division 1 Hazardous Location Brakes (for atmospheres containing explosive gases or ignitable dusts) / Foot Mounted													
10-105	87,300				④	④	④						
125-330	82,300							④	④	④			
Division 2 Hazardous Location Brakes													
1.5-25	56,800		①	①	②	②	②						
6-105	87,800		③	③	①	①	①	②	②	②	②		
Double C-Face Brake Couplers (for direct coupling a C-face motor to a C-face gear reducer)													
1.5-25	56,700		①	①									
10-105	87,700				①	①	①						

① Brake mounts directly to motor C-face.

② Adapter required to mount brake to motor C-face. Refer to brake specifications for adapter information.

③ Brake endplate modified for direct mounting to motor C-face without an adapter.

④ Brake is foot mounted for coupling to a hazardous-location motor.

Series 48,100 (1-048-1XX)

Mounting Face: NEMA 48C

3.0" AK, 3.75" AJ

Static Torque: 1.5 through 6 lb-ft

IP Rating: 23

Enclosure Material: Stamped steel housing

Enclosure Type: UL Type 1

Release Type: Side lever

Modifications: See SAB modifications section.

Installation & Service Instructions:

P/N 8-078-924-06

Parts List: P/N 8-078-914-02



Features

- Spring-set electrically released
- Adjustable torque
- Manual wear adjustment
- Side manual release lever with automatic reset
- Coil insulation: Class 180(H)
- Lead wire length: 24 inches
- Maximum speed: horizontal 5000 rpm
- cURus File E71115 certified

Series 48,100

Model Number*	Nominal Static Torque lb-ft (Nm)	Weight lbs (kg)
1-048-151-00-XX	1.5 (2)	4.6 (2.1)
1-048-151-01-XX	1.5 (2)	4.6 (2.1)
1-048-161-00-XX	3 (4)	4.6 (2.1)
1-048-161-01-XX	3 (4)	4.6 (2.1)
1-048-171-00-XX	6 (8)	5 (2.3)
1-048-171-01-XX	6 (8)	5 (2.3)

*Eighth and ninth positions designate lead wire position: 00=internal and external 01=internal only.

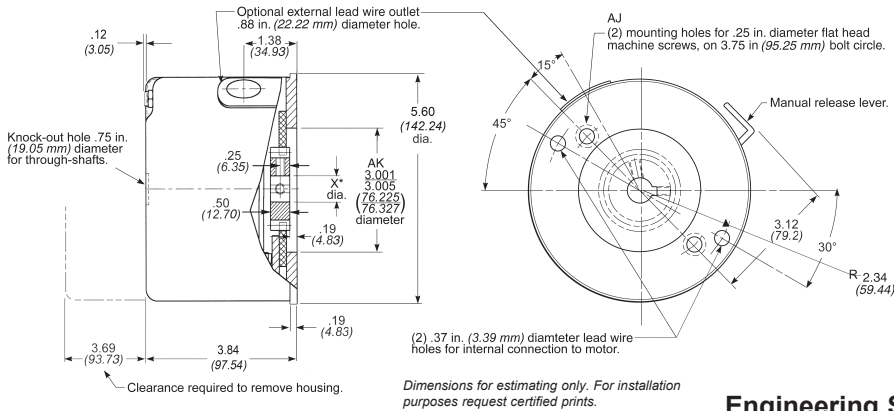

Current Rating (amperes)

Coil Size	Coil Strength	Current	Voltage: 60 Hz			
			115 Vac	230 Vac	460 Vac	575 Vac
4	3	Inrush Holding	1.9 0.5	0.9 0.2	0.5 0.1	0.4 0.1
			2.4 0.6	1.2 0.3	0.6 0.2	0.5 0.1
4	7	Inrush Holding	2.4 0.6	1.2 0.3	0.6 0.2	0.5 0.1

Engineering Specifications

Nominal Static Torque lb-ft (Nm)	Number of Friction Discs	Coil Size	Coil Strength	Maximum Solenoid Cycle Rate ^① cycles/min	Thermal Capacity ^② hp-sec/min (watts)	Inertia (WK ²) lb-ft ² (kgm ² x 10 ⁻⁴)
3 (4)	1	4	3	36	4 (50)	.003 (1.26)
6 (8)	1	4	7	36	4 (50)	.003 (1.26)

- ① Maximum solenoid cycle rate is based on ambient temperature of 72°F (22°C) with 50% duty cycle. Does not relate to brake cycle rate (see thermal capacity).
- ② Thermal capacity rating is based on ambient temperature of 72°F (22°C), stop time of one second or less, with no heat absorbed from motor. Derate thermal capacity by 25% for vertical mounting. Refer to selection procedure section.

Ordering & Identification Information

The following example and tables provide information for selecting the appropriate three-letter suffix when ordering a Stearns brake.

Example of a complete part number:

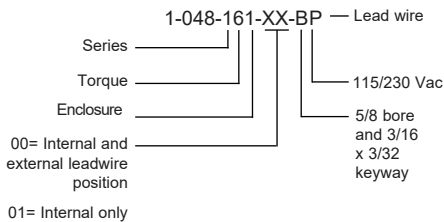

Hub Selection

Character	Bore (in.)	Keyway** (in. x in.)
A*	5/8	1/8 x 1/16
B	5/8	3/16 x 3/32
C*	3/4	3/16 x 3/32
K	1/2	1/8 x 1/16

Maximum allowable bore .750. For through-shaft applications .625 is maximum.

*These bores are non-standard.

**Keyseats made to ANSI B17.1 Standard.

SAB Voltage Chart

Voltage Character in Brake P/N	Coil Type ⁴	Nominal Voltage ^{1,2} [VAC]					
		Wiring Configuration #1		Wiring Configuration #2			
		@60Hz	@50Hz	@60Hz	@50Hz		
B	1	115	95	N/A			
D		132	110				
E		200	165				
F		230	190				
H		264	220				
L		460	380				
N	575	480	110				
O	2	264			220	132	110
P		230³			190	115	95
Q		460			380	230³	190
R		400			330	200	165

AC Single Voltage

Wiring Config #1

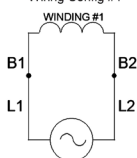

AC Dual Voltage

Wiring Config #1: High Voltage

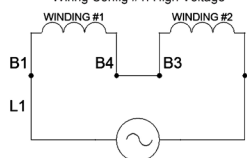

AC Dual Voltage

Wiring Config #2: Low Voltage

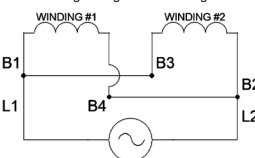

1. Bold text is the more common voltage and frequency combination.
2. Operating Voltage Range is ± 10%
3. If it's a Size 4 coil, the coil voltage is 208-230 (with a minimum operating voltage of 200VAC).
4. 1=AC single voltage; 2=AC dual voltage.

56,X00 Series

Mounting Face: NEMA 56C, 143TC & 145TC

Features

- Spring-set electrically released
- Static torque 1.5 through 25 lb-ft
- Adjustable torque, down to 50% of rated nameplate torque
- Manual wear adjustment
- Air gap adjust gage
- Splined hub
- IP rating: 21, 23, 54/56*, 56
- Enclosure: UL Type 1, UL Type 4X
- Universal mounting through 15 lb-ft. The 20 and 25 lb-ft are supplied with springs for vertical modification.
- Lead wire length: 24 inches
- Maximum speed:
Horizontal 5000 rpm
Vertical 3600 rpm
- Coil insulation: Class 180(H)
- cURus File E71115 certified
- ABS type approval certified

Product Overview

56,000 Series

Designed for industrial applications requiring high performance in a compact lightweight package.

IP Rating: 23, 54/56*, 56

Enclosure Material: Die cast aluminum endplate with stamped steel housing.

Enclosure Type: UL Type 1, UL Type 4X

Release Type: External knob manual release with or without automatic reset.

Through Shaft Capability**: Yes



56,700 Series

Units designed for industrial applications that fit between a standard C-Face motor and gear reducer. Can also be used to retrofit installed units without braking capability.

IP Rating: 23, 54/56*, 56

Enclosure Material: Die cast aluminum endplate and housing.

Enclosure Type: UL Type 1, UL Type 4X

Release Type: External knob manual release with automatic reset.

C-face brake has output shaft.

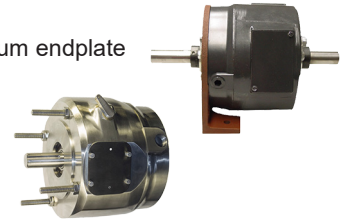

56,200 Series

Designed for industrial applications requiring the protection of a heavy duty cast iron enclosure.

IP Rating: 54/56*, 56

Enclosure Material: Cast iron endplate and housing.

Enclosure Type: UL Type 1, UL Type 4X

Release Type: External side lever release with automatic reset.

Through Shaft Capability**: Yes



Also Available . . .

56,100 Series

Full die cast aluminum endplate and housing with internal release lever.

IP Rating: 23, 54/56*, 56

Enclosure Type: UL Type 1, UL Type 4X



56,300 Series

Die cast aluminum endplate with stamped steel housing and external maintained release.

IP Rating: 21

Enclosure Type: UL Type 1



56,500 Series

Same as 56,000 Series with 182TC / 184TC mounting.

IP Rating: 23, 54/56*, 56

Enclosure Material: Cast iron endplate with stamped steel housing (direct mount to 182TC / 184TC).

Enclosure Type: UL Type 1, UL Type 4X

Release Type: External knob manual release with or without automatic reset.

Through Shaft Capability**: Yes



56,400 Series

Cast iron endplate with stamped steel housing and external knob release.

IP Rating: 23, 54/56*

Enclosure Type: UL Type 1



56,600 Series

Cast iron endplate and housing with internal release lever.

IP Rating: 23, 54/56*, 56

Enclosure Type: UL Type 1, UL Type 4X



56,900 Series

For use in severe environments found in process industries such as food, pulp and paper mills and chemical plants.

IP Rating: 56

Enclosure Material: Stainless steel

Enclosure Type: UL Type 4X

Release Type: Side lever with automatic reset.

Through Shaft Capability**: Yes



* IP 54; IP 56 with motor gasket.

**Adding through-shaft enclosure may affect IP rating. See M19 or M20 modifications for details.

Series 56,000; 56,100; 56,200; 56,300; 56,400; 56,500; 56,600; 56,700 & 56,900

Mounting Face: NEMA 56C, 143TC & 145TC

Engineering Specifications

Maximum Solenoid Cycle Rate: ① AC 36 cycles/min
 Thermal Capacity: ②
 Horizontal 9 hp-sec/min (112 watts)
 Vertical 6.5 hp-sec/min (80 watts)

- ① Maximum solenoid cycle rate is based on ambient temperature of 72°F (22°C) with 50% duty cycle. Does not relate to brake cycle rate (see thermal capacity).
- ② Thermal capacity rating is based on ambient temperature of 72°F (22°C), stop time of one second or less, with no heat absorbed from motor. Refer to selection procedure section.

Series 56,000; 56,100; 56,300; 56,500 & 56,700

Nominal Static Torque	Number of Friction Discs	Coil Size	Inertia (WK ²)
lb-ft (Nm)			lb-ft ² (kgm ² x 10 ⁻⁴)
1.5-3 (2-4)	1	4	.008 (3.36)
6 (8)	1	4	.008 (3.36)
10 (14)	2	4	.014 (5.88)
15 (20)	2	4	.014 (5.88)
20 (27)	3	4	.020 (8.40)
25 (34)	3	4	.020 (8.40)

Series 56,200; 56,400; 56,600 & 56,900

Nominal Static Torque	No. of Friction discs	Coil Size	Inertia (WK ²)
lb-ft (Nm)			lb-ft ² (kgm ² x 10 ⁻⁴)
3-6 (4-8)	2	4	.014 (5.88)
10 (14)	2	4	.014 (5.88)
15 (20)	2	4	.014 (5.88)
20 (27)	3	4	.020 (8.40)
25 (34)	3	4	.020 (8.40)

Current Ratings (amperes)

Coil Size	Current	Voltage: 60 Hz						Voltage: 50 Hz		
		115 Vac	200 Vac	230 Vac	400 Vac	460 Vac	575 Vac	110 Vac	220 Vac	380 Vac
4	Inrush Holding	4.6 .4	2.5 .2	2.3 .2	1.2 .1	1.0 .1	.9 .08	4.1 .4	2.0 .2	1.3 .1

Motor Frame Adapters: Series 56,000* through 56,600

WARNING! Before selecting an adapter to mount a brake on a larger motor frame, the torque and thermal capacity required by the application should be determined as shown in the selection procedure section. A larger motor may indicate a requirement for greater thermal capacity than the brake is designed for. The brake selection must be matched to the motor and application requirements, before use of an adapter is considered.

To Adapt to NEMA Frame Size	AK Dim.	Reg. No.	Brake Torque	Adapter Stock Number	Additional Shaft Length Required
	in. (mm)				in. (mm)
182TC 184TC 213TC 215TC 254TC 256TC	8.50 (215.90)	-9	1.5-6	5-55-5041-00	.94 (23.81)
	8.50 (215.90)	-9	10-25	5-55-5043-00	.94 (23.81)

*56,300 Series have UL Type 1 enclosure. For adapter dimensions, see technical data.

AC Single Voltage

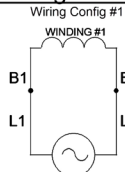

AC Dual Voltage

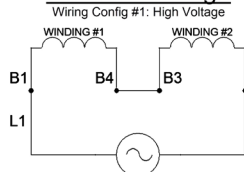

AC Dual Voltage

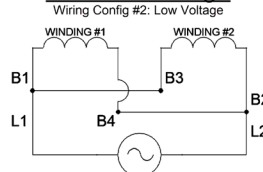

Brake set and release times in milliseconds, when brake and motor are switched separately (for T1/T2 definitions, see set and release times section):

Static Torque lb-ft	Coil Size	T1	T2
1.5 - 25	4	25	14

Ordering & Identification Information

The following example and tables provide information for selecting the appropriate three-letter suffix when ordering a Stearns brake.

Example of a complete part number:

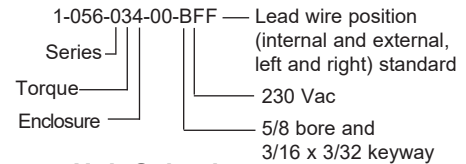

Hub Selection

Character	Bore (in.)	Keyway** (in. x in.)
A*	5/8	1/8 x 1/16
B	5/8	3/16 x 3/32
C	3/4	3/16 x 3/32
D	7/8	3/16 x 3/32
E	1-1/8	1/4 x 1/8
F*	1-1/4	1/4 x 1/8
K	1/2	1/8 x 1/16
L*	1	1/4 x 1/8
N*	9/16	1/8 x 1/16
O*	11/16	3/16 x 3/32
P*	1-1/16	1/4 x 1/8
R*	13/16	3/16 x 3/32
S*	15/16	1/4 x 1/8
Z	.460	pilot bore

Minimum bore is .500. Maximum allowable bore is 1.25 (maximum shaft length not to exceed end of hub). For through-shaft applications, .875 is maximum.

*These bores are non-standard.

**Keyseats made to ANSI B17.1 Standard.

SAB Voltage Chart

Voltage Character in Brake P/N	Coil Type ⁴	Nominal Voltage ^{1,2} [VAC]			
		Wiring Configuration #1		Wiring Configuration #2	
		@60Hz	@50Hz	@60Hz	@50Hz
B	1	115	95	N/A	
D		132	110		
E		200	165		
F		230	190		
H		264	220		
L		460	380		
M		498	415		
N		575	480		
O	2	264	220	132	110
P		230³	190	115	95
Q		460	380	230³	190
R		400	330	200	165

1. Bold text is the more common voltage and frequency combination.
 2. Operating Voltage Range is ± 10%
 3. If it's a Size 4 coil, the coil voltage is 208-230 (with a minimum operating voltage of 200VAC).
 4. 1=AC single voltage; 2=AC dual voltage.
- Modifications are available - see SAB modification section.
 Dimensional drawings are the pages following.

**Series 56,000 (1-056-0XX-00) &
Series 56,000-80 (1-056-0XX-80)**
Mounting Face: NEMA 56C,
143TC & 145TC
4.5" AK, 5.88" AJ



Static Torque: 1.5 through 25 lb-ft

IP Rating: 23, 54/56*, 56

Enclosure Material: Lightweight steel housing, aluminum endplate

Enclosure Type: UL Type 1, UL Type 4X

Release Type: Rear knob manual release

Mounting: Fanguard mounted brakes requiring IP 56 protection require additional sealing measures beyond seals provided with the brake.

Modifications: See SAB modifications section.

Installation & Service Instructions: P/N 8-078-905-60

Parts List: P/N 8-078-906-00

Series 56,000

Nominal Static Torque lb-ft (Nm)	IP Rating	Enclosure	Basic Model Number
1.5 (2)	IP 23	UL Type 1	1-056-001-00
	IP 54/56*	UL Type 1	1-056-002-00
	IP 56	UL Type 4X	1-056-004-00
3 (4)	IP 23	UL Type 1	1-056-011-00
	IP 54/56*	UL Type 1	1-056-012-00
6 (8)	IP 23	UL Type 1	1-056-021-00
	IP 54/56*	UL Type 1	1-056-022-00
10 (14)	IP 23	UL Type 1	1-056-031-00
	IP 54/56*	UL Type 1	1-056-032-00
15 (20)	IP 23	UL Type 1	1-056-041-00
	IP 54/56*	UL Type 1	1-056-042-00
20 (27)	IP 23	UL Type 1	1-056-051-00
	IP 54/56*	UL Type 1	1-056-052-00
25 (34)	IP 23	UL Type 1	1-056-061-00
	IP 54/56*	UL Type 1	1-056-062-00
	IP 56	UL Type 4X	1-056-064-00

Series 56,000-80**

Nominal Static Torque lb-ft (Nm)	IP Rating	Enclosure	Basic Model Number
1.5 (2)	IP 54/56*	UL Type 1	1-056-002-80**
3 (4)	IP 54/56*	UL Type 1	1-056-012-80**
6 (8)	IP 54/56*	UL Type 1	1-056-022-80**
10 (14)	IP 54/56*	UL Type 1	1-056-032-80**
15 (20)	IP 54/56*	UL Type 1	1-056-042-80**
20 (27)	IP 54/56*	UL Type 1	1-056-052-80**
25 (34)	IP 54/56*	UL Type 1	1-056-062-80**

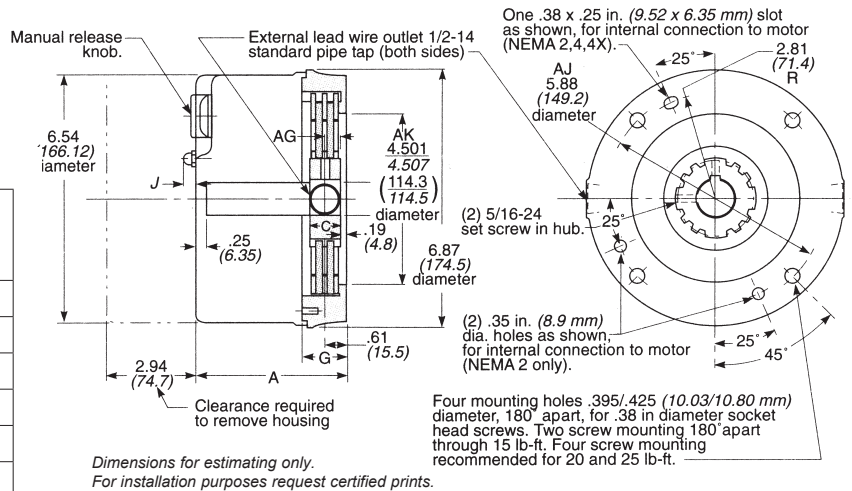

IP 23 Dimensions

Nominal Static Torque lb-ft (Nm)	Dimensions in Inches (Dimensions in Millimeters)					Wt lbs (Kg)
	A	AG	C Hub Width	G	J	
1.5 (2)						8 (3.6)
3 (4)						8 (3.6)
6 (8)	4.06 (103.1)	.52 (13.2)	.81 (20.6)	1.23 (31.2)	.31 (7.9)	8 (3.6)
10 (14)						8 (3.6)
15 (20)						8 (3.6)
20 (27)	4.50 (114.3)	.52 (13.2)	1.18 (30.0)	1.66 (42.2)	.31 (7.9)	9 (4.0)
25 (34)						9 (4.0)

IP 54/56* & 56 Dimensions

Nominal Static Torque lb-ft (Nm)	Dimensions in Inches (Dimensions in Millimeters)					Wt lbs (Kg)
	A	AG	C Hub Width	G	J	
1.5 (2)						8 (3.6)
3 (4)	4.06 (103.1)	.47 (11.9)	.81 (20.6)	1.21 (30.7)	.37 (9.4)	8 (3.6)
6 (8)						8 (3.6)
10 (14)						9 (4.0)
15 (20)	4.51 (114.6)	.59 (15.0)	1.18 (30.0)	1.66 (42.2)	.37 (9.4)	9 (4.0)
20 (27)						9 (4.0)
25 (34)						9 (4.0)

* IP 54; IP 56 with motor gasket.

** 56,000-80 Series includes a C-face gasket only, no hub seal.

Series 56,200 (1-056-2XX) Cast Iron & Series 56,900 (1-056-9XX) Stainless Steel

Mounting Face: NEMA 56C, 143TC & 145TC

4.5" AK, 5.88" AJ

Series 56,200

Static Torque: 3 through 25 lb-ft

IP Rating: 54/56*, 56

Enclosure Material: Heavy duty cast iron

Enclosure Type: UL Type 1, UL Type 4X

Release Type: External side lever release with automatic reset

Mounting: Fanguard mounted brakes requiring IP 56 protection require additional sealing measures beyond seals provided with the brake.

Modifications: See SAB modifications section.

Installation & Service Instructions:

P/N 8-078-905-60

Parts List: P/N 8-078-906-02



Series 56,200

Nominal Static Torque lb-ft (Nm)	IP Rating	Enclosure	Basic Model Number
3 (4)	IP 54/56*	UL Type 1	1-056-212-00
	IP 56	UL Type 4X	1-056-214-00
6 (8)	IP 54/56*	UL Type 1	1-056-222-00
	IP 56	UL Type 4X	1-056-224-00
10 (14)	IP 54/56*	UL Type 1	1-056-232-00
	IP 56	UL Type 4X	1-056-234-00
15 (20)	IP 54/56*	UL Type 1	1-056-242-00
	IP 56	UL Type 4X	1-056-244-00
20 (27)	IP 54/56*	UL Type 1	1-056-252-00
	IP 56	UL Type 4X	1-056-254-00
25 (34)	IP 54/56*	UL Type 1	1-056-262-00
	IP 56	UL Type 4X	1-056-264-00

* IP 54; IP 56 with motor gasket.

Series 56,200 & 56,900 Dimensions & Drawing

Nominal Static Torque lb-ft (Nm)	Dimensions in Inches (Dimensions in Millimeters)				Wt lbs (Kg) 56,200	Wt lbs (Kg) 56,900
	A	AG	C Hub Width	G		
3 (4)	4.67 (118.6)	.59 (15.0)	1.18 (30.0)	1.66 (42.2)	17 (7.7)	17 (7.7)
6 (8)					17 (7.7)	17 (7.7)
10 (14)					18 (8.0)	17 (7.7)
15 (20)					18 (8.0)	17 (7.7)
20 (27)					21 (9.5)	21 (9.5)
25 (34)					21 (9.5)	21 (9.5)

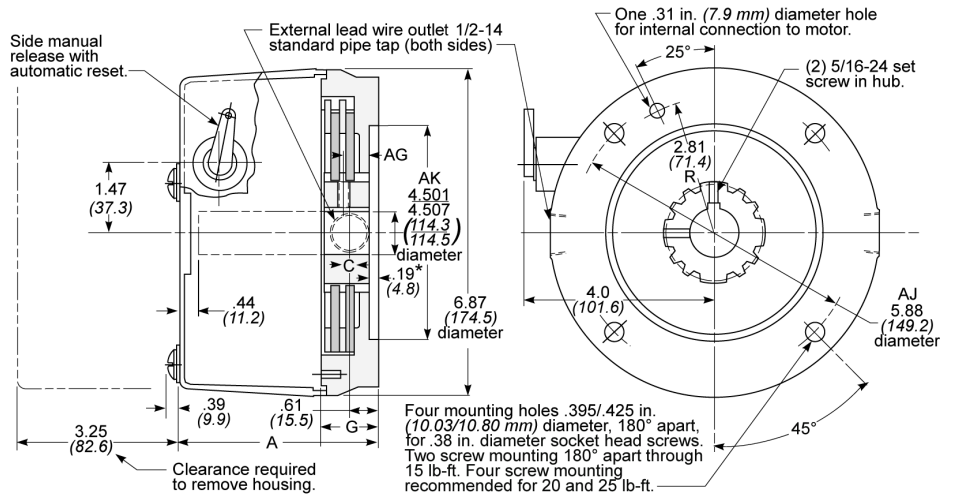

Dimensions for estimating only. For installation purposes request certified prints.

Series 56,900

Static Torque: 3 through 25 lb-ft

IP Rating: 56

Enclosure Material: Stainless steel

Enclosure Type: UL Type 4X

Release Type: Side lever with automatic reset

Mounting: Fanguard mounted brakes requiring IP 56 protection require additional sealing measures beyond seals provided with the brake.

Modifications: See SAB modifications section.

Installation & Service Instructions:

P/N 8-078-905-60

Parts List: P/N 8-078-906-09



Series 56,900

Nominal Static Torque lb-ft (Nm)	IP Rating	Basic Model Number	Enclosure
3 (4)	IP 56	1-056-914-00	UL Type 4X
6 (8)	IP 56	1-056-924-00	UL Type 4X
10 (14)	IP 56	1-056-934-00	UL Type 4X
15 (20)	IP 56	1-056-944-00	UL Type 4X
20 (27)	IP 56	1-056-954-00	UL Type 4X
25 (34)	IP 56	1-056-964-00	UL Type 4X

Series 56,300 (1-056-3XX)

Mounting Face: NEMA 56C, 143TC & 145TC , 4.5" AK, 5.88" AJ



Static Torque: 1.5 through 25 lb-ft
IP Rating: 21
Enclosure Material: Stamped steel housing, cast aluminum endplate
Enclosure Type: UL Type 1
Release Type: External lever, maintained
Modifications: See SAB modification section.
Installation & Service Instructions:
 P/N 8-078-905-60
Parts List: P/N 8-078-906-03

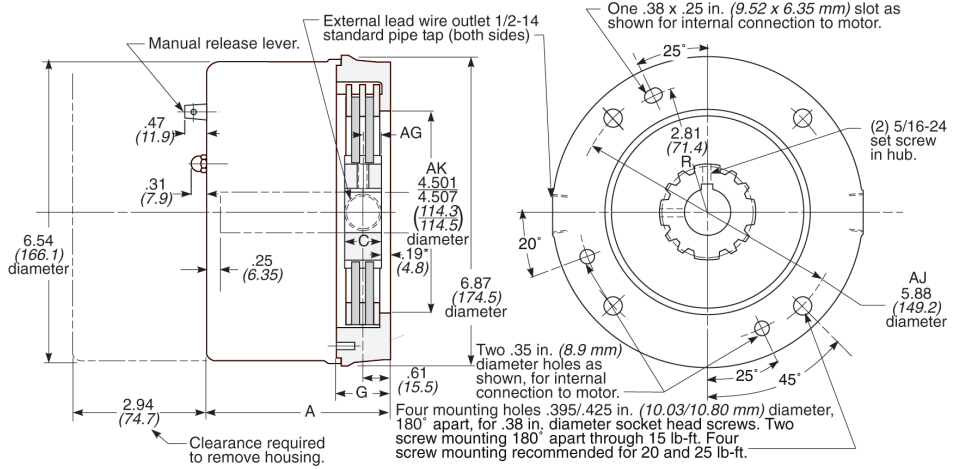

Series 56,300

IP 21 Dimensions

Nominal Static Torque lb-ft (Nm)	IP Rating**	Enclosure	Basic Model Number
1.5 (2)	IP 21	UL Type 1	1-056-301-00
3 (4)	IP 21	UL Type 1	1-056-311-00
6 (8)	IP 21	UL Type 1	1-056-321-00
10 (14)	IP 21	UL Type 1	1-056-331-00
15 (20)	IP 21	UL Type 1	1-056-341-00
20 (27)	IP 21	UL Type 1	1-056-351-00
25 (34)	IP 21	UL Type 1	1-056-361-00

Nominal Static Torque lb-ft (Nm)	Dimensions in Inches (Dimensions in Millimeters)				Wt lbs (Kg)
	A	AG	C Hub Width	G	
1.5 (2)	4.01 (101.9)	.59 (15.0)	.81 (20.6)	1.21 (30.7)	8 (3.6)
3 (4)					8 (3.6)
6 (8)					8 (3.6)
10 (14)					8 (3.6)
15 (20)					8 (3.6)
20 (27)	4.46 (113.3)	.59 (15.0)	1.18 (30.0)	1.66 (42.2)	9 (4.0)
25 (34)	4.46 (113.3)	.59 (15.0)	1.18 (30.0)	1.66 (42.2)	9 (4.0)

**All IP ratings based on horizontal configurations.

Series 56,400 (1-056-4XX)

Static Torque: 3 through 25 lb-ft
IP Rating: 23, 54/56*
Enclosure Material: Stamped steel housing, cast iron endplate
Enclosure Type: UL Type 1
Release Type: External knob, maintained
Mounting: Fanguard mounted brakes requiring IP 56 protection require additional sealing measures beyond seals provided with the brake.
Modifications: See SAB modifications section.
Installation & Service Instructions: P/N 8-078-905-60
Parts List: P/N 8-078-906-04

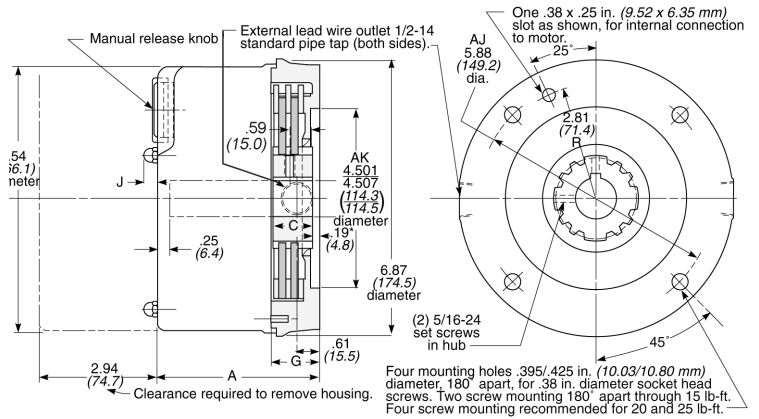

Series 56,400

IP 23 Dimensions

IP 54/56* Dimensions

Nominal Static Torque lb-ft (Nm)	IP Rating	Basic Model Number	Enclosure
3 (4)	IP 23	1-056-411-00	UL Type 1
	IP 54/56*	1-056-412-00	UL Type 1
6 (8)	IP 23	1-056-421-00	UL Type 1
	IP 54/56*	1-056-422-00	UL Type 1
10 (14)	IP 23	1-056-431-00	UL Type 1
	IP 54/56*	1-056-432-00	UL Type 1
15 (20)	IP 23	1-056-441-00	UL Type 1
	IP 54/56*	1-056-442-00	UL Type 1
20 (27)	IP 23	1-056-451-00	UL Type 1
	IP 54/56*	1-056-452-00	UL Type 1
25 (34)	IP 23	1-056-461-00	UL Type 1
	IP 54/56*	1-056-462-00	UL Type 1

Nominal Static Torque lb-ft (Nm)	Dimensions in Inches (mm)			Wt lbs (Kg)
	A	C Hub Width	G	
3 (4)	4.46 (113.3)	1.18 (30.0)	1.66 (42.2)	11 (5.0)
6 (8)				11 (5.0)
10 (14)				11 (5.0)
15 (20)				12 (5.5)
20 (27)				12 (5.5)
25 (34)	13 (6.0)			

Nominal Static Torque lb-ft (Nm)	Dimensions in Inches (mm)			Wt lbs (Kg)
	A	C Hub Width	G	
3 (4)	4.51 (114.6)	1.18 (30.0)	1.66 (42.2)	12 (5.5)
6 (8)				12 (5.5)
10 (14)				12 (5.5)
15 (20)				13 (6.0)
20 (27)				13 (6.0)
25 (34)	13 (6.0)			

* IP 54; IP 56 with motor gasket.

Series 56,100 (1-056-1XX) Die Cast Aluminum & Series 56,600 (1-056-6XX) Cast Iron

Mounting Face: NEMA 56C, 143TC & 145TC , 4.5" AK, 5.88" AJ

Static Torque: 1.5 through 25 lb-ft

IP Rating: 23, 54/56*, 56

56,100 Series Enclosure Material: Die cast aluminum

56,600 Series Enclosure Material: Cast iron

Enclosure Type: UL Type 1, UL Type 4X

Release Type: Internal lever, non-maintained

Mounting: Fanguard mounted brakes requiring IP 56 protection require additional sealing measures beyond seals provided with the brake.

Modifications: See SAB modifications section.

Installation & Service Instructions: P/N 8-078-905-60

56,100 Series Parts List: P/N 8-078-906-01

56,600 Series Parts List: P/N 8-078-906-06

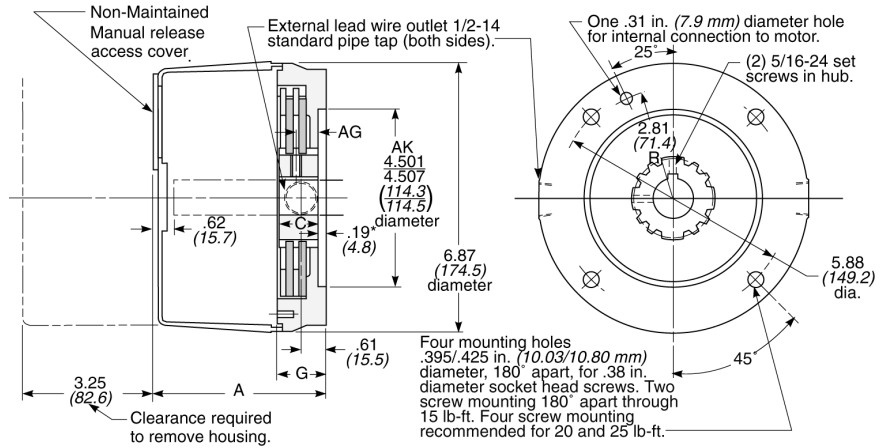

Series 56,100 Dimensions

Nominal Static Torque lb-ft (Nm)	IP Rating	Dimensions in Inches (mm)				Wt lbs (Kg)
		A	AG	C Hub Width	G	
1.5-15 (2-20)	IP 23	4.41 (112.0)	.59 (15.0)	.81 (20.6)	1.21 (30.7)	8 (3.6)
		4.86 (123.4)		1.18 (30.0)	1.66 (42.2)	10 (4.5)
1.5-6 (2-8)	IP 54/56*	4.50 (114.3)	.47 (11.9)	.81 (20.6)	1.21 (30.7)	8 (3.6)
10-25 (14-34)		4.95 (125.7)	.59 (15.0)	1.18 (30.0)	1.66 (42.2)	10 (4.5)

Series 56,600 Dimensions

Nominal Static Torque lb-ft (Nm)	IP Rating	Dimensions in Inches (mm)				Wt lbs (Kg)
		A	AG	C Hub Width	G	
3-25 (4-34)	IP 23	4.95 (125.7)	.59 (15.0)	1.18 (30.0)	1.66 (42.2)	21 (9.5)
3-25 (4-34)	IP 54/56*	5.05 (128.3)				

Series 56,100

Nominal Static Torque lb-ft (Nm)	IP Rating	Basic Model Number	Enclosure
1.5 (2)	IP 23	1-056-101-00	UL Type 1
	IP 54/56*	1-056-102-00	UL Type 1
	IP 56	1-056-104-00	UL Type 4X
3 (4)	IP 23	1-056-111-00	UL Type 1
	IP 54/56*	1-056-112-00	UL Type 1
	IP 56	1-056-114-00	UL Type 4X
6 (8)	IP 23	1-056-121-00	UL Type 1
	IP 54/56*	1-056-122-00	UL Type 1
	IP 56	1-056-124-00	UL Type 4X
10 (14)	IP 23	1-056-131-00	UL Type 1
	IP 54/56*	1-056-132-00	UL Type 1
	IP 56	1-056-134-00	UL Type 4X
15 (20)	IP 23	1-056-141-00	UL Type 1
	IP 54/56*	1-056-142-00	UL Type 1
	IP 56	1-056-144-00	UL Type 4X
20 (27)	IP 23	1-056-151-00	UL Type 1
	IP 54/56*	1-056-152-00	UL Type 1
	IP 56	1-056-154-00	UL Type 4X
25 (34)	IP 23	1-056-161-00	UL Type 1
	IP 54/56*	1-056-162-00	UL Type 1
	IP 56	1-056-164-00	UL Type 4X

Series 56,600

Nominal Static Torque lb-ft (Nm)	IP Rating	Basic Model Number	Enclosure
3 (4)	IP 23	1-056-611-00	UL Type 1
	IP 54/56*	1-056-612-00	UL Type 1
	IP 56	1-056-614-00	UL Type 4X
6 (8)	IP 23	1-056-621-00	UL Type 1
	IP 54/56*	1-056-622-00	UL Type 1
	IP 56	1-056-624-00	UL Type 4X
10 (14)	IP 23	1-056-631-00	UL Type 1
	IP 54/56*	1-056-632-00	UL Type 1
	IP 56	1-056-634-00	UL Type 4X
15 (20)	IP 23	1-056-641-00	UL Type 1
	IP 54/56*	1-056-642-00	UL Type 1
	IP 56	1-056-644-00	UL Type 4X
20 (27)	IP 23	1-056-651-00	UL Type 1
	IP 54/56*	1-056-652-00	UL Type 1
	IP 56	1-056-654-00	UL Type 4X
25 (34)	IP 23	1-056-661-00	UL Type 1
	IP 54/56*	1-056-662-00	UL Type 1
	IP 56	1-056-664-00	UL Type 4X

* IP 54; IP 56 with motor gasket.

Series 56,500 (1-056-5XX)

Mounting Face: NEMA 182TC & 184TC

8.5" AK, 7.25" AJ

Static Torque: 10 through 25 lb-ft

IP Rating: 23, 54/56*, 56

Enclosure Material: Stamped steel housing, cast iron endplate

Enclosure Type: UL Type 1, UL Type 4X

Release Type: External knob, manual release with or without automatic reset

Mounting: Fanguard mounted brakes requiring IP 56 protection require additional sealing measures beyond seals provided with the brake.

Modifications: See SAB modifications section.

Installation & Service Instructions:

P/N 8-078-905-60

Parts List: P/N 8-078-906-05

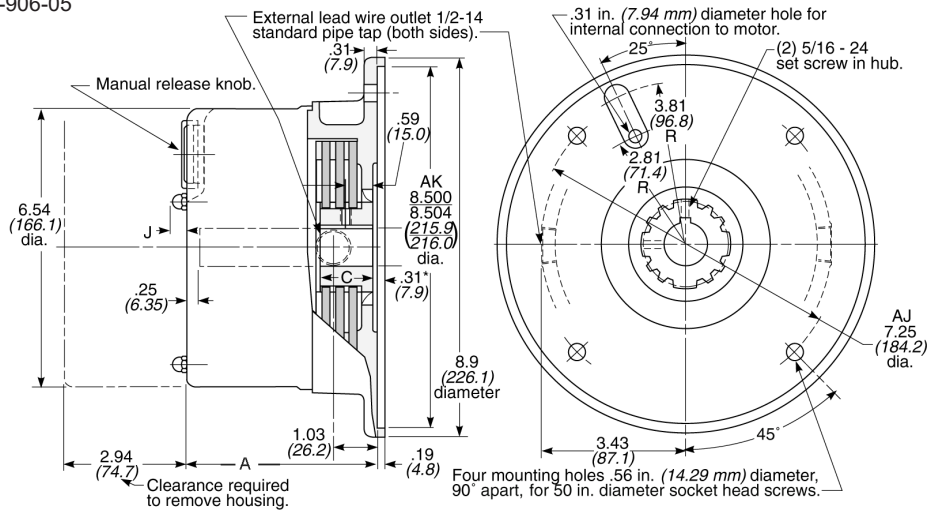

* Hub location.

Dimensions for estimating only. For installation purposes request certified prints.

IP 23 Dimensions

Nominal Static Torque lb-ft (Nm)	Dimensions in Inches (Dimensions in Millimeters)			Wt lbs (Kg)
	A	C Hub Width	J	
10 (14)	4.46 (113.3)	.81 (20.6)	.31 (7.9)	14 (6.4)
15 (20)				14 (6.4)
20 (27)				14 (6.4)
25 (34)				15 (6.8)

IP 54/56* Dimensions

Nominal Static Torque lb-ft (Nm)	Dimensions in Inches (Dimensions in Millimeters)			Wt lbs (Kg)
	A	C Hub Width	J	
10 (14)	4.51 (114.6)	1.18 (30.0)	.37 (9.4)	14 (6.4)
15 (20)				14 (6.4)
20 (27)				15 (6.8)
25 (34)				15 (6.8)

Series 56,500

Nominal Static Torque lb-ft (Nm)	IP Rating	Basic Model Number	Enclosure
10 (14)	IP 23	1-056-531-00	UL Type 1
	IP 54/56*	1-056-532-00	UL Type 1
	IP 56	1-056-534-00	UL Type 4X
15 (20)	IP 23	1-056-541-00	UL Type 1
	IP 54/56*	1-056-542-00	UL Type 1
	IP 56	1-056-544-00	UL Type 4X
20 (27)	IP 23	1-056-551-00	UL Type 1
	IP 54/56*	1-056-552-00	UL Type 1
	IP 56	1-056-554-00	UL Type 4X
25 (34)	IP 23	1-056-561-00	UL Type 1
	IP 54/56*	1-056-562-00	UL Type 1
	IP 56	1-056-564-00	UL Type 4X

* IP 54; IP 56 with motor gasket.

Series 87,000 & 87,100

Mounting Face: NEMA 182TC - 256TC/UC

87,X00* Series Features

- Self-adjusting design
- Spined hub
- Lead wire length: 24 in
- Maximum speed: horizontal 4000 rpm, vertical 3600 rpm (modification required - see SAB modification section)
- Coil insulation: Class 180(H)
- cURus File E71115 certified
- ABS type approval certified
- *Does not include 87,300 and 87,700 Series brakes

Engineering Specifications

Nominal Static Torque lb-ft (Nm)	No. of Friction Discs	Coil Size	Maximum Solenoid Cycle Rate ¹ cycles/min	Thermal Capacity ² hp-sec/min (watts)	Inertia (Wk ²) lb-ft ² (kgm ² x 10 ⁻⁴)		
					87,000	87,100	87,700
6 (8)	1	5	30	17.5 (218)	.048 (20.34)	—	—
10 (14)	1	5	30	17.5 (218)	.048 (20.34)	—	.078 (32.76)
15 (20)	1	6	25	17.5 (218)	.048 (20.34)	—	.078 (32.76)
25 (34)	1	6	25	17.5 (218)	.048 (20.34)	—	.078 (32.76)
35 (47)	1	8	20	17.5 (218)	.048 (20.34)	—	.078 (32.76)
50 (68)	2	6	25	17.5 (218)	.089 (37.40)	.089 (37.40)	.108 (45.36)
75 (102)	2	8	20	17.5 (218)	.089 (37.40)	.089 (37.40)	.108 (45.36)
105 (142)	3	8	20	17.5 (218)	.129 (54.45)	.129 (54.45)	.145 (60.90)
125 (169)	3	8	20	20.0 (248)	—	.129 (54.45)	—

- ① Maximum solenoid cycle rate is based on ambient temperature of 72°F (22°C) with 50% duty cycle. Does not relate to brake cycle rate (see thermal capacity).
- ② Thermal capacity rating is based on ambient temperature of 72°F (22°C), stop time of one second or less, with no heat absorbed from motor. Derate thermal capacity by 25% for vertical mounting. Refer to selection procedure section.
87,800 Thermal capacity is 14 hp-sec/min (174 watts).

Motor Frame Adapters/Special Endplate

To Adapt to NEMA Frame Size	in. (mm)	Reg. No.	Adapter Stock Number	Additional Shaft Length Required in. (mm)
56C, 143TC, or 145TC 182TFC, 184TFC	4.50 (114.30)	-05	Brake endplate is modified for 4.50 in AK.	— (—)
284TC 286TC	10.50 (266.70)	-11	5-55-7043-00	.56 (14.22)
D80 D90	—	-10	5-55-7055-00	.81 (20.64)
D80 D90	—	-10	Endplate modified for 130mm register (AK) and 165mm bolt circle (AJ).	—
324TC, 326TC, 364TC, 365TC, 404TC or 405TC	12.50 (317.50)	-13	5-55-7046-00	.88 (22.22)
Pre-NEMA	—	-07	Endplate modified to provide a 6.75" male register (AK) and 7.19" bolt circle (AJ).	—
182TC/184TC, 213TC, 215TC, 254TC/256TC	8.5 (215.90)	-03	Extended endplate.	.625 (15.88)

For motor frame adapters: Series 87,000 through 87,800 see technical data.

Current Ratings (amperes)

Coil Size	AC Current	Voltage: 60 Hz					Voltage: 50 Hz			
		115	200	230	400	460	575	110	220	380
5	inrush	7.5	4.3	3.7	2.2	1.9	1.5	5.4	4.0	1.9
	holding	.5	.3	.2	.1	.1	.09	.3	.3	.1
6	inrush	13.0	7.5	6.5	3.7	3.2	2.6	9.4	5.6	3.2
	holding	.6	.4	.3	.2	.2	.1	.5	.3	.2
8	inrush	17.6	10.3	8.8	5.0	4.2	3.5	15.4	7.7	4.2
	holding	1.2	.7	.6	.3	.3	.3	1.0	.5	.3

Ordering & Identification Information

The following example and tables provide information for selecting the appropriate three-letter suffix when ordering a Stearns brake.

Example of a complete part number:

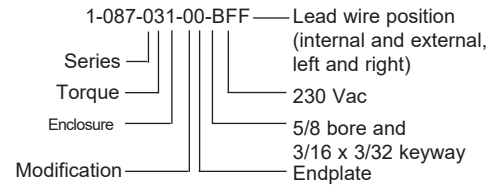

Hub Selection

Character	Bore (in.)	Keyway** (in. x in.)
A*	5/8	1/8 x 1/16
B*	5/8	3/16 x 3/32
C*	3/4	3/16 x 3/32
D	7/8	3/16 x 3/32
E	1-1/8	1/4 x 1/8
F	1-1/4	1/4 x 1/8
G	1-3/8	5/16 x 5/32
H	1-5/8	3/8 x 3/16
I*	1-3/4	3/8 x 3/16
J*	1-7/8	1/2 x 1/4
L*	1	1/4 x 1/8
M*	1-1/2	3/8 x 3/16
O*	11/16	3/16 x 3/32
P*	1-1/16	1/4 x 1/8
Q*	1-7/16	3/8 x 3/16
R*	13/16	3/16 x 3/32
S*	15/16	1/4 x 1/8
T*	1-3/16	1/4 x 1/8
U*	1-5/16	5/16 x 5/32
Z	.600	pilot bore

Maximum allowable bore 1.875 (maximum shaft length not to exceed end of hub). For thru-shaft applications 1.625 is maximum.

*These bores are non-standard.

**Keyseats made to ANSI B17.1 standard.

SAB Voltage Chart

Voltage Character in Brake P/N	Coil Type ⁴	Nominal Voltage ^{1,2} [VAC]			
		Wiring Configuration #1		Wiring Configuration #2	
		@60Hz	@50Hz	@60Hz	@50Hz
B	1	115	95	N/A	
D		132	110		
E		200	165		
F		230	190		
H		264	220		
L		460	380		
M		498	415		
N	575	480			
O	2	264	220	132	110
P		230³	190	115	95
Q		460	380	230³	190
R		400	330	200	165

1. Bold text is the more common voltage and frequency combination.
 2. Operating Voltage Range is ± 10%
 3. If it's a Size 4 coil, the coil voltage is 208-230 (with a minimum operating voltage of 200VAC).
 4. 1=AC single voltage; 2=AC dual voltage.
- Dimensional drawings are the pages following.

AC Single Voltage

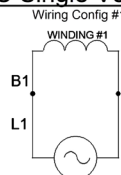

AC Dual Voltage

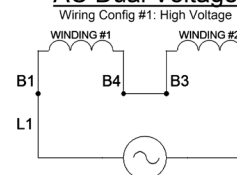

AC Dual Voltage

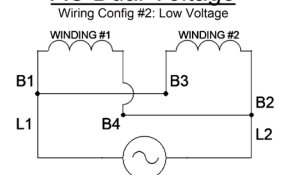

Series 87,000

Mounting Face: NEMA 182TC, 184TC, 213TC,
215TC, 254TC & 256TC

(Note: for 182TFC & 184TFC mounting,
add a -05- register)

8.5" AK, 7.25" AJ

Static Torque: 6 through 125 lb-ft

IP Rating: 23, 54/56*, 56

Enclosure Material: Sheet metal housing, aluminum endplate; cast iron housing and endplate

Enclosure Type: UL Type 1, UL Type 4X

Release Type: Pull release knob, maintained with automatic reset. Vertical above IP 56 supplied with side manual release lever; all cast iron IP 56 brakes supplied with side manual release lever.

Mounting: Horizontal, unless modified for vertical. Vertical mounting is defined as 15° or more from horizontal. Vertical above requires modification. Vertical below requires modification on 50-105 lb-ft brakes. Vertical above IP 56 includes side manual release.

Fanguard mounted brakes requiring IP 56 protection require additional sealing measures beyond seals provided with the brake.

Specifications (Bore Sizes & Voltages): See previous page.

Modifications: See SAB modifications section.

Installation, Service & Parts List: P/N 8-078-928-01 Rev. B brakes



Brake set and release times in milliseconds, when brake and motor are switched separately (for T1/T2 definitions, see set and release times section):

Static Torque	Coil Size	T1	T2
10, 15, 25, 50	5 & 6	42	20
35, 75, 105	8	48	20

Outline Drawing for 1-087-0X2 Cast Iron Housing & Endplate IP 54/56* & 56

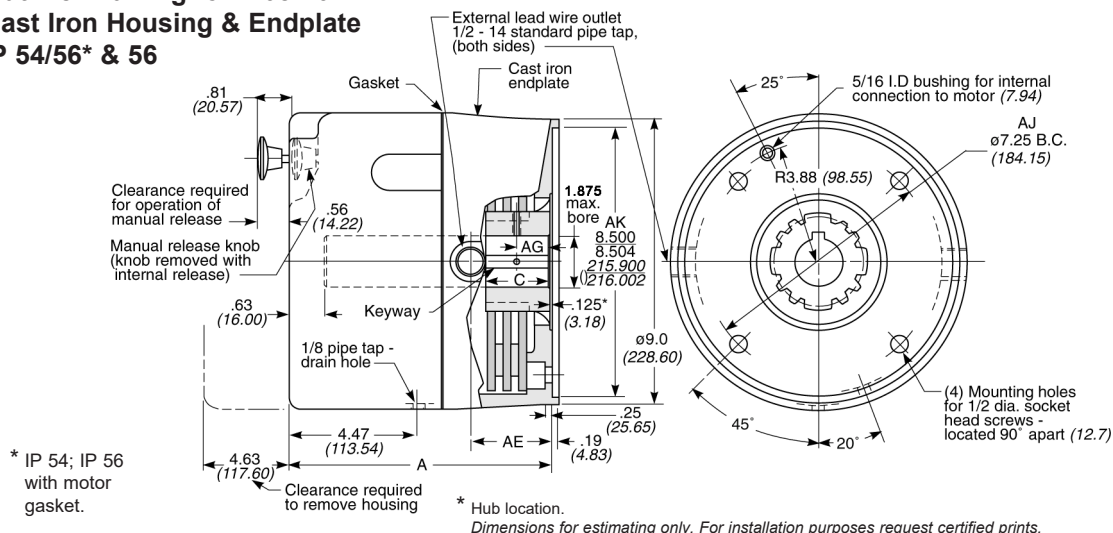

Outline Drawing for 1-087-0X1 & 1-087-0X4 Sheet Metal Housing, Aluminum Endplate IP 23, 54/56* & 56

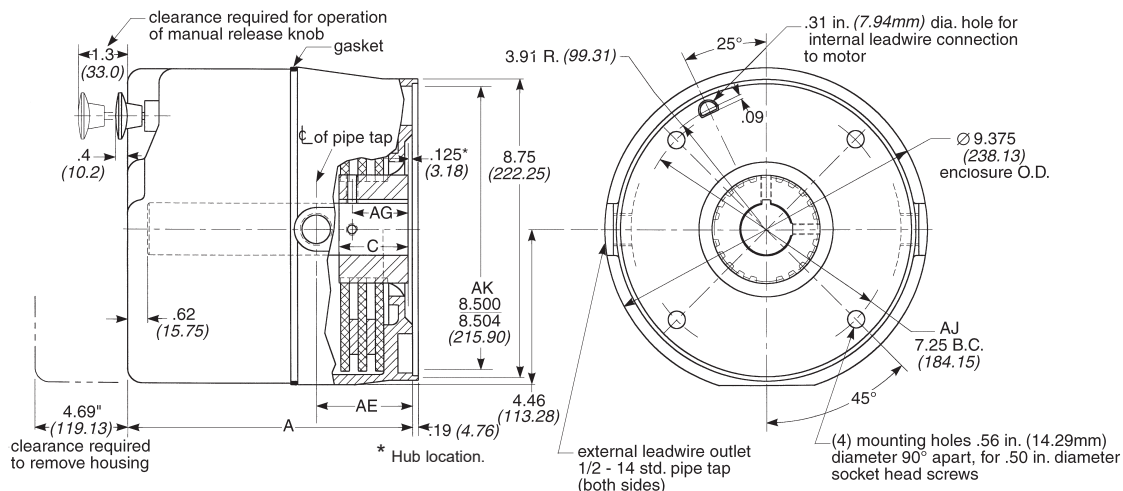

Series 87,000 Dimensions

IP 23 - Sheet Metal Housing, Aluminum Endplate

Nominal Static Torque lb-ft (Nm)	IP Rating	Basic Model Number	Enclosure	Dimensions in Inches (Dimensions in Millimeters)				Wt. lbs (kg)**
				A	AE	AG	C Hub Width	
6 (8)	IP 23	1-087-001-00	UL Type 1	7.38 (187.32)	1.81 (46.04)	.68 (17.29)	1.00 (25.40)	20 (9.0)
10 (14)	IP 23	1-087-011-00	UL Type 1					20 (9.0)
15 (20)	IP 23	1-087-021-00	UL Type 1					22 (10.0)
25 (34)	IP 23	1-087-031-00	UL Type 1					22 (10.0)
35 (47)	IP 23	1-087-041-00	UL Type 1					24 (11.0)
50 (68)	IP 23	1-087-051-00	UL Type 1	7.88 (200.02)	2.31 (58.74)	.97 (24.64)	1.50 (38.10)	22 (10.0)
75 (102)	IP 23	1-087-061-00	UL Type 1					27 (12.2)
105 (142)	IP 23	1-087-081-00	UL Type 1					33 (15.0)

IP 54/56* & 56 - Cast Iron Housing & Endplate

Nominal Static Torque lb-ft (Nm)	IP Rating	Basic Model Number	Enclosure	Dimensions in Inches (Dimensions in Millimeters)				Wt. lbs (kg)**
				A	AE	AG	C Hub Width	
6 (8)	IP 54/56*	1-087-002-00	UL Type 1	7.56 (192.09)	1.81 (46.04)	.68 (17.29)	1.00 (25.40)	44 (20.0)
	IP 56	1-087-002-B0	UL Type 4X					44 (20.0)
10 (14)	IP 54/56*	1-087-012-00	UL Type 1					46 (21.0)
	IP 56	1-087-012-B0	UL Type 4X					
15 (20)	IP 54/56*	1-087-022-00	UL Type 1					46 (21.0)
	IP 56	1-087-022-B0	UL Type 4X					
25 (34)	IP 54/56*	1-087-032-00	UL Type 1					48 (21.7)
	IP 56	1-087-032-B0	UL Type 4X					
35 (47)	IP 54/56*	1-087-042-00	UL Type 1					51 (23.0)
	IP 56	1-087-042-B0	UL Type 4X					
50 (68)	IP 54/56*	1-087-052-00	UL Type 1	8.06 (204.79)	2.31 (58.74)	.97 (24.64)	1.50 (38.10)	52 (24.0)
	IP 56	1-087-052-B0	UL Type 4X					52 (24.0)
75 (102)	IP 54/56*	1-087-062-00	UL Type 1	8.56 (217.49)	2.81 (71.44)	.97 (24.64)	2.00 (50.80)	56 (25.4)
	IP 56	1-087-062-B0	UL Type 4X					56 (25.4)
105(142)	IP 54/56*	1-087-082-00	UL Type 1	8.56 (217.49)	2.81 (71.44)	.97 (24.64)	2.00 (50.80)	56 (25.4)
	IP 56	1-087-082-B0	UL Type 4X					56 (25.4)
125 ¹ (169)	IP 54/56*	1-087-092-00	UL Type 1	8.56 (217.49)	2.81 (71.44)	.97 (24.64)	2.00 (50.80)	56 (25.4)
	IP 56	1-087-092-B0	UL Type 4X					56 (25.4)

¹ These model numbers include non-standard friction discs. For high inertia or overhauling loads, it is recommended that 81,000 or 82,000 series brakes be used, as these brakes have substantially higher thermal capacities (50% higher for 81,000 series and 150% higher for 82,000 series).

IP 54/56* & 56 - Sheet Metal Housing, Aluminum Endplate

Nominal Static Torque lb-ft (Nm)	IP Rating	Basic Model Number	Enclosure	Dimensions in Inches (Dimensions in Millimeters)				Wt. lbs (kg)**
				A	AE	AG	C Hub Width	
6 (8)	IP 54/56*	1-087-004-00	UL Type 1	7.43 (188.59)	1.81 (46.04)	.68 (17.29)	1.00 (25.40)	19 (8.6)
	IP 56	1-087-004-B0	UL Type 4X					19 (8.6)
10 (14)	IP 54/56*	1-087-014-00	UL Type 1					20 (9.0)
	IP 56	1-087-014-B0	UL Type 4X					
15 (20)	IP 54/56*	1-087-024-00	UL Type 1					20 (9.0)
	IP 56	1-087-024-B0	UL Type 4X					
25 (34)	IP 54/56*	1-087-034-00	UL Type 1					22 (10.0)
	IP 56	1-087-034-B0	UL Type 4X					
35 (47)	IP 54/56*	1-087-044-00	UL Type 1					23 (10.4)
	IP 56	1-087-044-B0	UL Type 4X					
50 (68)	IP 54/56*	1-087-054-00	UL Type 1	7.93 (201.28)	2.31 (58.74)	.97 (24.64)	1.50 (38.10)	23 (10.4)
	IP 56	1-087-054-B0	UL Type 4X					23 (10.4)
75 (102)	IP 54/56*	1-087-064-00	UL Type 1	8.43 (213.97)	2.81 (71.44)	.97 (24.64)	2.00 (50.80)	24 (11.0)
	IP 56	1-087-064-B0	UL Type 4X					24 (11.0)
105 (142)	IP 54/56*	1-087-084-00	UL Type 1	8.43 (213.97)	2.81 (71.44)	.97 (24.64)	2.00 (50.80)	24 (11.0)
	IP 56	1-087-084-B0	UL Type 4X					24 (11.0)

* IP 54; IP 56 with motor gasket.

**Foot mounting adds 7 lbs. (3.2 kg) to weight.

Series 87,000 Dimensions

IP 56 - Cast Iron Housing & Endplate Internal Encoder Mount

Nominal Static Torque lb-ft (Nm)	IP Rating	Enclosure	Basic Model Number	Dimensions in Inches (Dimensions in Millimeters)						Wt. Lbs (kg)
				A	C	AG	AE	SL		
								min	max ¹	
25 (34)	IP 56	UL Type 1	1-087-030-00	8.63	1.50	0.97	2.63	1.88	8.00	75 (34)
35 (47)	IP 56	UL Type 1	1-087-040-00	8.63	1.50	0.97	2.63	1.88	8.00	75 (34)
50 (68)	IP 56	UL Type 1	1-087-050-00	8.63	1.50	0.97	2.63	1.88	8.00	75 (34)
75 (102)	IP 56	UL Type 1	1-087-060-00	8.63	1.50	0.97	2.63	1.88	8.00	76 (34.5)
105 (142)	IP 56	UL Type 1	1-087-080-00	9.13	2.00	0.97	3.13	2.38	8.50	80 (36.3)

¹ SL max for 1.875" max dia. shaft = 2.32" for 50 & 75 lb-ft brakes, & 2.82" for 105 lb-ft brake.

Engineering Specifications

Nominal Static Torque lb-ft (Nm)	No. of Friction Discs	Coil Size	Maximum Solenoid Cycle Rate cycles/min	Thermal Capacity hp-sec/min (watts)	Inertia (Wk ²) lb-ft ² (kgm ² x 10 ⁻⁴)
25 (34)	2	6	25	17.5 (21.8)	.089 (37.40)
35 (47)	2	6	25	17.5 (21.8)	.089 (37.40)
50 (68)	2	6	25	17.5 (21.8)	.089 (37.40)
75 (102)	2	8	20	17.5 (21.8)	.089 (37.40)
105 (142)	3	8	20	17.5 (21.8)	.129 (54.45)

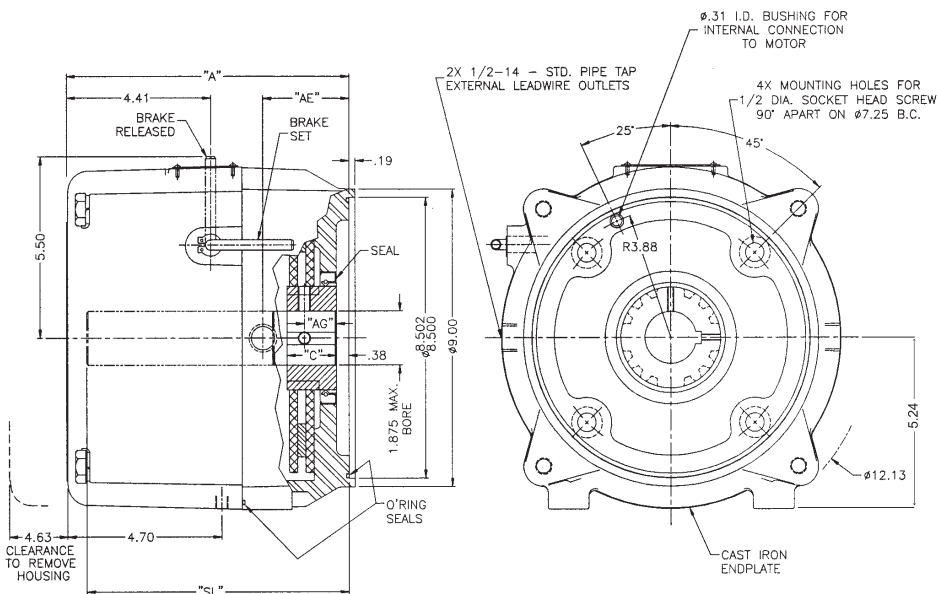

Series 87,100 (1-087-1XX)

Mounting Face: NEMA 284TC,

284UC, 286TC & 286UC

10.5" AK, 9.0" AJ

Static Torque: 50 through 125 lb-ft

IP Rating: 23, 54/56*

Enclosure Material: Sheet metal housing, cast iron endplate; cast iron housing and endplate

Enclosure Type: UL Type 1

Release Type: Knob, maintained with automatic reset. Vertical above IP 54 supplied with side release lever.

Mounting: Horizontal, unless modified for vertical. Vertical mounting is defined as 15° or more from horizontal. Vertical above and vertical below require modification. Vertical above NEMA 4/4X includes side manual release.

Fanguard mounted brakes requiring IP 56 protection require additional sealing measures beyond those provided with the brake.

Specifications (Bore Sizes & Voltages): See previous pages.

Modifications: See SAB modifications section.

Installation, Service & Parts List: P/N 8-078-928-01 Rev. B brakes



Brake set and release times in milliseconds, when brake and motor are switched separately (for T1/T2 definitions, see set and release times section):

Static Torque	Coil Size	T1	T2
50	6	42	20
35, 75, 105, 125	8	48	20

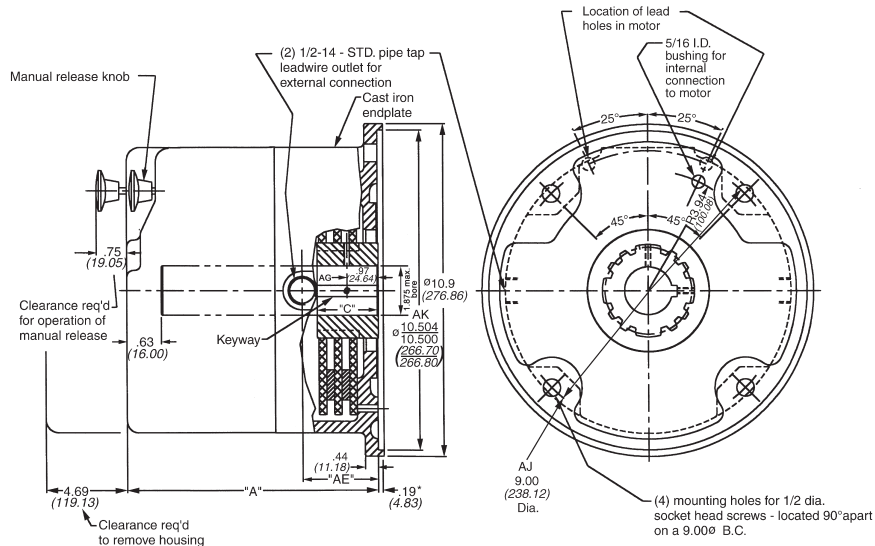

* Hub location

Dimensions for estimating only. For installation purposes request certified prints.

Dimensions

Nominal Static Torque lb-ft	IP Rating	Enclosure	Basic Model Number	Dimensions in Inches (Dimensions in Millimeters)				Wt. lbs (kg)
				A	AE	AG	C	
50	IP 23	UL Type 1	1-087-151-00	7.75 (196.85)	2.19 (55.56)	.97 (24.64)	1.50 (38.10)	40 (18.0)
50	IP 54/56*	UL Type 1	1-087-152-00	7.94 (201.68)	2.19 (55.56)	.97 (24.64)	1.50 (38.10)	53 (24.0)
75	IP 23	UL Type 1	1-087-161-00	7.75 (196.85)	2.19 (55.56)	.97 (24.64)	1.50 (38.10)	44 (20.0)
75	IP 54/56*	UL Type 1	1-087-162-00	7.94 (201.68)	2.19 (55.56)	.97 (24.64)	1.50 (38.10)	52 (23.6)
105	IP 23	UL Type 1	1-087-181-00	8.25 (209.55)	2.69 (68.26)	.97 (24.64)	2.00 (50.80)	46 (19.0)
105	IP 54/56*	UL Type 1	1-087-182-00	8.44 (214.31)	2.69 (68.26)	.97 (24.64)	2.00 (50.80)	58 (26.3)
125'	IP 23	UL Type 1	1-087-191-00	8.25 (209.55)	2.69 (68.26)	.97 (24.64)	2.00 (50.80)	46 (19.0)
125'	IP 54/56*	UL Type 1	1-087-192-00	8.44 (214.31)	2.69 (68.26)	.97 (24.64)	2.00 (50.80)	58 (26.3)

*IP 54; IP 56 with motor gasket.

¹ These model numbers include non-standard friction discs. For high inertia or overhauling loads, it is recommended that 81,000 or 82,000 series brakes be used, as these brakes have substantially higher thermal capacities (50% higher for 81,000 series and 150% higher for 82,000 series).

Series 81,000 & 82,000

Mounting Face: NEMA 324 & 326TC, TSC, UC or USC, NEMA 364 & 365TC, TSC, UC or USC
NEMA 404 & 405TC, TSC, UC or USC

81,000 Series Engineering Specifications

Nominal Static Torque lb-ft (Nm)	No. of Friction Discs	Coil Size	Coil Strength	Maximum Solenoid Cycle Rate ^① cycles/min	Thermal Capacity ^② hp-sec/min (watts)	Inertia (Wk ²) lb-ft ² (kgm ² x 10 ⁻³)
125 (169)	2	9	3	15	30 (373)	.192 (8.06)
175 (237)	2	9	3	15	30 (373)	.192 (8.06)
230 (312)	3	9	3	15	30 (373)	.280 (11.76)

82,000 Series Engineering Specifications

Nominal Static Torque lb-ft (Nm)	No. of Friction Discs	Coil Size	Coil Strength	Maximum Solenoid Cycle Rate ^① cycles/min	Thermal Capacity ^② hp-sec/min (watts)	Inertia (Wk ²) lb-ft ² (kgm ² x 10 ⁻³)
125 (169)	2	9	3	15	50 (621)	.490 (20.58)
175 (237)	2	9	3	15	50 (621)	.490 (20.58)
230 (312)	3	9	3	15	50 (621)	.704 (29.57)
330 (447)	3	9	4	13	50 (621)	.704 (29.57)
440 (597)	4	9	4	13	50 (621)	.918 (38.56)

① Maximum solenoid cycle rate is based on ambient temperature of 72°F (22°C) with 50% duty cycle. Does not relate to brake cycle rate (see thermal capacity).

② Thermal capacity rating is based on ambient temperature of 72°F (22°C) stop time of one second or less, with no heat absorbed from motor. Refer to selection procedure section. Derate thermal capacity by 25% for vertical mounting.

Ordering & Identification Information

The following example and tables provide information for selecting the appropriate three-letter suffix when ordering a Stearns brake.

Example of a complete part number, Series 81,000:

1-081-011-02-NLF — Lead wire position (internal and external, left and right)
460 Vac
2-1/8 bore and 1/2 x 1/4 keyway

81,000 Series Hub Selection

Character	Bore (in.)	Keyway** (in. x in.)
A*	1 1/8	1/4 X 1/8
B*	1 1/4	1/4 X 1/8
C	1 3/8	5/16 X 5/32
D	1 1/2	3/8 X 3/16
E*	1 9/16	3/8 X 3/16
F*	1 5/8	3/8 X 3/16
G*	1 11/16	3/8 X 3/16
H	1 3/4	3/8 X 3/16
I*	1 13/16	1/2 x 1/4
J	1 7/8	1/2 x 1/4
K*	1 15/16	1/2 x 1/4
L*	2	1/2 x 1/4
M*	2 1/16	1/2 x 1/4
N	2 1/8	1/2 x 1/4
O*	2 3/16	1/2 x 1/4
P*	2 1/4	1/2 x 1/4
Q*	2 5/16	5/8 x 5/16
R	2 3/8	5/8 x 5/16
S*	2 7/16	5/8 x 5/16
T	2 1/2	5/8 x 5/16
W	1 1/8	pilot bore

Maximum allowable bore 2.500 in. (76.200 mm) (maximum shaft length not to exceed end of hub).

*These bores are non-standard.

**Keyseats made to ANSI B17.1 standard.

82,000 Series Hub Selection

Character	Bore (in.)	Keyway** (in. x in.)
A	1 1/8	1/4 X 1/8
B*	1 1/4	1/4 X 1/8
C	1 3/8	5/16 X 5/32
D	1 1/2	3/8 X 3/16
E*	1 9/16	3/8 X 3/16
F*	1 5/8	3/8 X 3/16
G*	1 11/16	3/8 X 3/16
H	1 3/4	3/8 X 3/16
I*	1 13/16	1/2 x 1/4
J	1 7/8	1/2 x 1/4
K*	1 15/16	1/2 x 1/4
L*	2	1/2 x 1/4
M*	2 1/16	1/2 x 1/4
N	2 1/8	1/2 x 1/4
O*	2 3/16	1/2 x 1/4
P*	2 1/4	1/2 x 1/4
Q*	2 5/16	5/8 x 5/16
R	2 3/8	5/8 x 5/16
S*	2 7/16	5/8 x 5/16
T	2 1/2	5/8 x 5/16
U*	2 5/8	5/8 x 5/16
V*	2 3/4	5/8 x 5/16
W	1 1/8	pilot bore
X	2 7/8	3/4 x 3/8
Y*	2 15/16	3/4 x 3/8
Z*	3	3/4 x 3/8

Maximum allowable bore 3.000 in. (76.200 mm) (maximum shaft length not to exceed end of hub).

*These bores are non-standard.

**Keyseats made to ANSI B17.1 standard.

Coil Strength

Coil Size	Coil Strength	Frequency	Voltage	Current	
				Inrush	Holding
9	3	60 Hz	115	44.0	1.6
			200	25.4	.9
			230	22.0	.8
			400	12.7	.5
			460	11.4	.4
			575	8.8	.3
	50 Hz	110	32.1	1.2	
		220	16.0	.6	
		380	11.1	.4	
		60 Hz	115	50.0	2.2
			200	28.0	1.3
			230	25.0	1.1
	400		14.0	.6	
	460		12.5	.6	
	575		10.0	.4	
	50 Hz	110	36.0	1.6	
		220	24.0	.9	
		380	12.5	.6	

AC Single Voltage

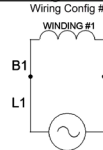

AC Dual Voltage

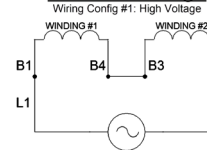

AC Dual Voltage

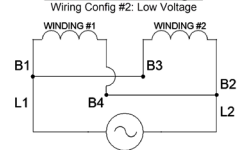

Example of a complete part number, Series 82,000:

1-082-012-02-NLF — Lead wire position (internal and external, left and right)
460 Vac
2-1/8 bore and 1/2 x 1/4 keyway

SAB Voltage Chart

Voltage Character in Brake P/N	Coil Type ^a	Nominal Voltage ^{1,2} [VAC]					
		Wiring Configuration #1		Wiring Configuration #2			
		@60Hz	@50Hz	@60Hz	@50Hz		
B	1	115	95	N/A			
D		132	110				
E		200	165				
F		230	190				
H		264	220				
L		460	380				
M		498	415				
N		575	480				
O		264	220			132	110
P		230³	190			115	95
Q	2	460	380	230³	190		
R		400	330	200	165		

1. Bold text is the more common voltage and frequency combination.

2. Operating Voltage Range is ± 10%

3. If it's a Size 4 coil, the coil voltage is 208-230 (with a minimum operating voltage of 200VAC).

4. 1=AC single voltage; 2=AC dual voltage.

Modifications are available - see SAB modification section.

Series 81,000 (1-081-0XX)

Mounting Face: NEMA 324 & 326 TC, TSC, UC or USC, NEMA 364 & 365 TC, TSC, UC or USC, NEMA 404 & 405TC, TSC, UC or USC
12.5" AK, 11.0" AJ

Static Torque: 125 through 230 lb-ft

IP Rating: 23, 54/56*

Enclosure Material: Cast iron

Enclosure Type: UL Type 1

Release Type: Knob, maintained with automatic reset. Vertical above IP 56 supplied with side release lever.

Mounting: Fanguard mounted brakes requiring IP 56 protection require additional sealing measures beyond seals provided with the brake.

Modifications: Modification required for vertical mounting. Vertical above IP 56 includes side release. See SAB modifications for details.

Installation, Service & Parts List: P/N 8-078-921-00



Features

- Spring-set electrically released
- Self-adjusting design
- Splined hub
- Lead wire length: 36 inches
- Maximum speed: 3600 horizontal, 2400 vertical
- Coil insulation: Class 180(H)
- cURus File E71115 certified
- ABS type approval certified

Brake set and release times in milliseconds, when brake and motor are switched separately (for T1/T2 definitions, see set and release times section):

Static Torque	Coil Size	T1	T2
All	9	56	27

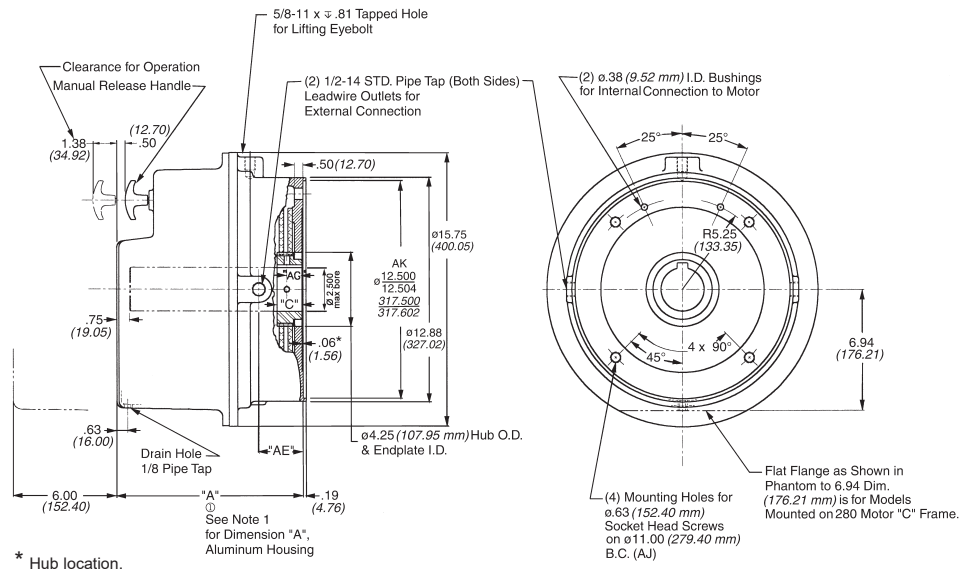

* Hub location.

Dimensions for estimating only. For installation purposes request certified prints.

Dimensions

Nominal Static Torque lb-ft (Nm)	IP Rating	Enclosure	Basic Model Number ^①	Dimensions in Inches (Dimensions in Millimeters)				Cast Iron Wt. lbs (kg) ^②
				A Cast Iron	AE	AG	C	
125 (169)	IP 23	UL Type 1	1-081-011-0X	10.81 (274.64)	2.56 (65.09)	.94 (23.81)	1.44 (36.51)	148 (67.0)
125 (169)	IP 54/56*	UL Type 1	1-081-012-0X	10.88 (276.22)	2.56 (65.09)	.94 (23.81)	1.44 (36.51)	151 (69.0)
175 (237)	IP 23	UL Type 1	1-081-021-0X	10.81 (274.64)	2.56 (65.09)	.94 (23.81)	1.44 (36.51)	148 (67.0)
175 (237)	IP 54/56*	UL Type 1	1-081-022-0X	10.88 (276.22)	2.56 (65.09)	.94 (23.81)	1.44 (36.51)	151 (69.0)
230 (312)	IP 23	UL Type 1	1-081-031-0X	11.31 (287.34)	3.06 (77.79)	1.44 (36.51)	1.94 (49.21)	155 (70.0)
230 (312)	IP 54/56*	UL Type 1	1-081-032-0X	11.38 (288.92)	3.06 (77.79)	1.44 (36.51)	1.94 (49.21)	158 (72.0)

*IP54; IP 56 with motor gasket.

① 9th digit indicates aluminum or cast iron housing.

2 = Cast iron

3 = Aluminum: add .38" to "A" dimension

② Subtract 21 lbs. for aluminum housing. Foot mounting adds 40 lbs (18.2 kg) to weight.

Motor Frame Adapters

WARNING! Before selecting an adapter to mount a brake on a larger motor frame, the torque and thermal capacity required by the application should be determined as shown in the selection procedure section. A larger motor may indicate a requirement for greater thermal capacity than the brake is designed for. The brake selection must be matched to the motor and application requirements, before use of an adapter is considered.

To Adapt to NEMA Frame Size	AK Dim.	Reg. No.	Adapter Stock Number	Additional Shaft Length Required
	in (mm)			in. (mm)
182TC, 184TC, 213TC, 215TC, 254TC or 256TC	8.50 (215.90)	-9	5-55-2041-00	.94 (23.81)
284TC or 286TC	10.50 (266.70)	-11	5-55-2043-00	.94 (23.81)
444TSC and 445TSC	16.00 (406.40)	-16	5-55-2045-00	.88 (22.22)

For adapter dimensions, see technical data.

Series 82,000 (1-082-0XX)

Mounting Face: NEMA 324 & 326 TC, TSC, UC or USC, NEMA 364 & 365 TC, TSC, UC or USC, NEMA 404 & 405TC, TSC, UC or USC
12.5" AK, 11.0" AJ

Static Torque: 125 through 440 lb-ft

IP Rating: 23, 54/56*

Enclosure Material: Cast iron

Enclosure Type: UL Type 1

Release Type: Knob, maintained with automatic reset. Vertical above IP 56 supplied with side release lever.

Mounting: Fanguard mounted brakes requiring IP 56 protection require additional sealing measures beyond seals provided with the brake.

Modifications: Modification required for vertical mounting. Vertical above IP 54 includes side release. See SAB modifications for details.

Installation, Service & Parts List: P/N 8-078-922-10 Rev. A brakes



Features

- Spring-set electrically released
- Self-adjusting design
- Splined hub
- Lead wire length: 36 inches
- Maximum speed: 3600 horizontal, 2400 vertical
- Coil insulation: Class 180(H)
- cURus File E71115 certified
- ABS type approval certified

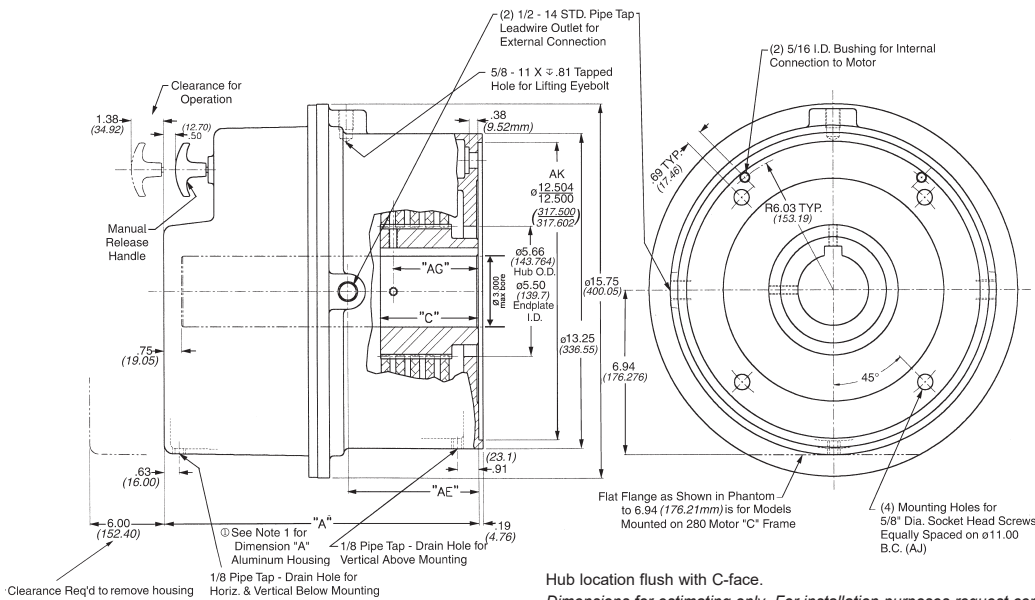

Brake set and release times in milliseconds, when brake and motor are switched separately (for T1/T2 definitions, see set and release times section):

Static Torque	Coil Size	T1	T2
All	9	56	27

Dimensions

Nominal Static Torque lb-ft (Nm)	IP Rating	Enclosure	Basic Model Number ^①	Dimensions in Inches (Dimensions in Millimeters)				Cast Iron Wt. lbs (kg) ^②
				A ^① Cast Iron	AE	AG	C	
125 (169)	IP 23	UL Type 1	1-082-011-0X	12.12 (307.98)	4.31 (109.54)	1.75 (44.45)	2.31 (58.74)	189 (86.0)
125 (169)	IP 54/56*	UL Type 1	1-082-012-0X	12.19 (309.56)	4.31 (109.54)	1.75 (44.45)	2.31 (58.74)	189 (86.0)
175 (237)	IP 23	UL Type 1	1-082-021-0X	12.12 (307.98)	4.31 (109.54)	1.75 (44.45)	2.31 (58.74)	189 (86.0)
175 (237)	IP 54/56*	UL Type 1	1-082-022-0X	12.19 (309.56)	4.31 (109.54)	1.75 (44.45)	2.31 (58.74)	189 (86.0)
230 (312)	IP 23	UL Type 1	1-082-031-0X	12.12 (307.98)	4.31 (109.54)	2.38 (60.32)	2.94 (74.61)	190 (86.0)
230 (312)	IP 54/56*	UL Type 1	1-082-032-0X	12.19 (309.56)	4.31 (109.54)	2.38 (60.32)	2.94 (74.61)	190 (86.0)
330 (447)	IP 23	UL Type 1	1-082-041-0X	12.12 (307.98)	4.31 (109.54)	2.38 (60.32)	2.94 (74.61)	190 (86.0)
330 (447)	IP 54/56*	UL Type 1	1-082-042-0X	12.19 (309.56)	4.31 (109.54)	2.38 (60.32)	2.94 (74.61)	190 (86.0)
440 (597)	IP 23	UL Type 1	1-082-051-0X	13.38 (339.72)	5.56 (141.29)	3.00 (76.20)	3.56 (90.49)	192 (87.0)
440 (597)	IP 54/56*	UL Type 1	1-082-052-0X	13.44 (341.31)	5.56 (141.29)	3.00 (76.20)	3.56 (90.49)	192 (87.0)

*IP 54; IP 56 with motor gasket.

**Internal lead wire hole not available with IP 56, only external left and right are available.

① 9th digit indicates aluminum or cast iron housing.

2 = Cast iron

3 = Aluminum: add .38" to "A" dimension

② Subtract 21 lbs. for aluminum housing. Foot mounting adds 40 lbs (18.2 kg) to weight.

Motor Frame Adapters

WARNING! Before selecting an adapter to mount a brake on a larger motor frame, the torque and thermal capacity required by the application should be determined as shown in the selection procedure section. A larger motor may indicate a requirement for greater thermal capacity than the brake is designed for. The brake selection must be matched to the motor and application requirements, before use of an adapter is considered.

To Adapt to NEMA Frame Size	AK Dim.	Reg. No.	Adapter Stock Number	Additional Shaft Length Required
	in (mm)			in (mm)
182TC, 184TC, 213TC, 215TC, 254TC or 256TC	8.50 (215.90)	-9	5-55-2042-00	1.19 (30.16)
284TC or 286TC	10.50 (266.70)	-11	5-55-2044-00	1.19 (30.16)
444TSC and 445TSC	16.00 (406.40)	-16	5-55-2046-00	1.75 (44.45)

For adapter dimensions, see technical data.

Series 86,000 (1-086-XXX)

Mounting Face: NEMA 444 & 445TC, TSC, UC or USC

16.0" AK, 14.0" AJ

Series 86,100 (1-086-1XX)

Mounting Face: NEMA 505TC, TSC, UC or USC

16.5" AK, 14.5" AJ

Static Torque: 500 through 1000 lb-ft

IP Rating: 23, 54/56*

Enclosure Material: Cast iron

Enclosure Type: UL Type 1

Release Type: Knob, maintained with automatic reset

Mounting: Fanguard mounted brakes requiring IP 56 protection require additional sealing measures beyond seals provided with the brake.

Modifications: Modification required for vertical mounting, available through 750 lb-ft only. See SAB modifications section.

Installation, Service & Parts List: P/N 8-078-926-00

Additional 86,000 Specs: Double solenoid design terminal block provided.



Features

- Spring-set electrically released
- Self-adjusting design
- Splined hub
- Lead wire length: 36 inches
- Maximum speed: 1800 rpm
- Coil insulation: Class 180(H)
- cURus File E71115 certified
- ABS type approval certified

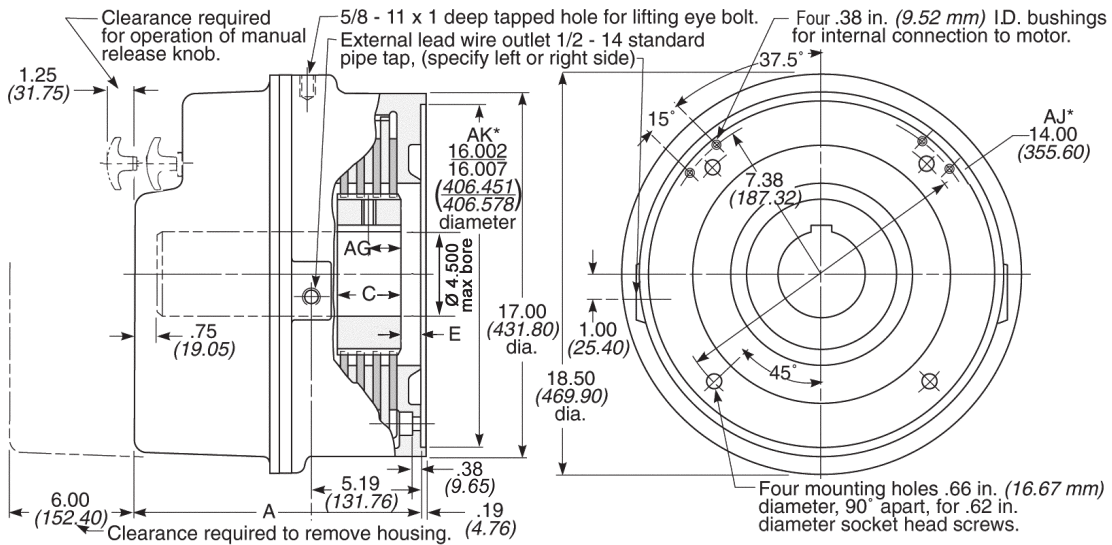

*86,100 Series AK = 16.502/16.507 AJ = 14.50

Dimensions for estimating only. For installation purposes request certified prints.

Dimensions

Nominal Static Torque lb-ft (Nm)	IP Rating	Enclosure	Basic Model Number ^①	Dimensions in Inches (Dimensions in Millimeters)				Cast Iron Wt. lbs (kg) ^②
				A Cast Iron	AG	C	E	
500 (678)	IP 23	UL Type 1	1-086-X21-02	13.31 (338.14)	.75 (19.05)	1.5 (38.1)	.94 (23.88)	310 (141.0)
500 (678)	IP 54/56*	UL Type 1	1-086-X22-02	13.38 (339.72)	1.69 (42.86)	2.44 (61.91)	.0 (0.0)	320 (145.0)
750 (1017)	IP 23	UL Type 1	1-086-X31-02	13.31 (338.14)	1.12 (28.58)	2.25 (57.15)	.94 (23.88)	330 (150.0)
750 (1017)	IP 54/56*	UL Type 1	1-086-X32-02	13.38 (339.72)	2.06 (52.39)	3.19 (80.96)	.0 (0.0)	340 (154.0)
1000 (1356)	IP 23	UL Type 1	1-086-X41-02	13.31 (338.14)	1.50 (38.10)	3.0 (76.2)	.94 (23.88)	350 (159.0)
1000 (1356)	IP 54/56*	UL Type 1	1-086-X42-02	13.38 (339.72)	2.44 (61.91)	3.94 (100.01)	.0 (0.0)	360 (164.0)

*IP 54; IP 56 with motor gasket.

**Internal lead wire hole not available with IP 56, only external left and right are available.

①X = 0 or 1. 0 designates a 16 in. "AK", 14 in "AJ". 1 designates 16.5 in. "AK", 14.5 in. "AJ".

②Foot mounting adds 75 lbs. (34 kg) to weight.

Motor Frame Adapters

To adapt to NEMA Frame Size	AK Dim	Reg. No.	Adapter Stock Number	Additional Shaft Length Required
	in. (mm)			in. (mm)
324TC, 326TC, 364TC, 365TC, 404TC or 405TC	12.50 (317.50)	-13	5-55-6041-00	1.38 (34.92)

For adapter dimensions, see technical data.

Series 86,000 Specifications Continued

Engineering Specifications*

Nominal Static Torque lb-ft (Nm)	No. of Friction Discs	Coil Size ①	Maximum Solenoid Cycle Rate ② cycles/min	Thermal Capacity ③ hp-sec/min (watts)	Inertia (Wk ²) lb-ft ² (kgm ² x 10 ⁻³)
500 (678)	2	9	13	80 (994)	1.4 (58.8)
750 (1017)	3	9	13	80 (994)	2.1 (88.2)
1000 (1356)	4	9	13	80 (994)	2.8 (117.6)

* All specifications are also applicable to the 86,100 Series.

- ① Two required.
- ② Maximum solenoid cycle rate is based on ambient temperature of 72°F (22°C) with 50% duty cycle. Does not relate to brake cycle rate (see thermal capacity).
- ③ Thermal capacity rating is based on ambient temperature of 72°F (22°C), stop time of one second or less, with no heat absorbed from motor. Derate thermal capacity by 25% for vertical mounting. Refer to selection procedure section.

Current Ratings (amperes)

Coil Size	Voltage: 60 Hz						
	Current	115 VAC	200 VAC	230 VAC	400 VAC	460 VAC	575 VAC
9	Inrush	100.4	56.0	50.0	28.0	25.0	20.0
	Holding	4.4	2.4	2.2	1.2	1.2	.8
	Voltage: 50 Hz						
9	Current	110 VAC	220 VAC	380 VAC			
	Inrush	72.0	48.0	25.0	—	—	—
	Holding	3.2	1.8	1.2	—	—	—

Ordering & Identification Information

The following example and tables provide information for selecting the appropriate three-letter suffix when ordering a Stearns brake.

Example of a complete part number: 1-086-031-02-NLF — Lead wire position (internal and external, left and right)

Designate 0 for 16 in. "AK", 14 in. "AJ" — 460 Vac

Designate 1 for 16.5 in. "AK", 14.5 in. "AJ" — 2-7/8 bore and 3/4 x 3/8 keyway

Hub Selection

Character	Bore (in.)	Keyway* (in. x in.)
D	2-1/8	1/2 x 1/14
H	2-3/8	5/8 x 5/16
K	2-5/8	5/8 x 5/16
L	2-3/4	5/8 x 5/16
N	2-7/8	3/4 x 3/8
P	3	3/4 x 3/8
T	3-3/8	7/8 x 7/16
V	3-1/2	7/8 x 7/16
W	1-7/8	pilot bore
Z	4	1 x 1/2

Maximum allowable bore 4.500 in. (maximum shaft length not to exceed end of hub)
For through-shaft applications, 4.000 is maximum.

*Keyseats made to ANSI B17.1 standard

SAB Voltage Chart

Voltage Character in Brake P/N	Coil Type ⁴	Nominal Voltage ^{1,2} [VAC]			
		Wiring Configuration #1		Wiring Configuration #2	
		@60Hz	@50Hz	@60Hz	@50Hz
B	1	115	95	N/A	
D		132	110		
E		200	165		
F		230	190		
H		264	220		
L		460	380		
M		498	415		
N		575	480		

1. Bold text is the more common voltage and frequency combination.
2. Operating Voltage Range is ± 10%
3. If it's a Size 4 coil, the coil voltage is 208-230 (with a minimum operating voltage of 200VAC).
4. 1=AC single voltage; 2=AC dual voltage.

AC Single Voltage

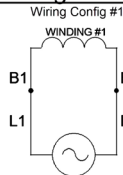

AC Dual Voltage

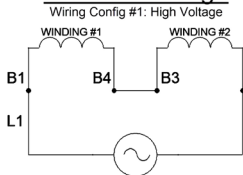

AC Dual Voltage

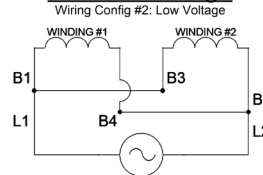

Hazardous Location Brakes

Enclosures for standard Stearns disc brakes are designed to prevent accidental contact with the internal mechanism while keeping contaminants from the operating parts. Many installations, however, require additional protection due to the presence of explosive gases or ignitable dusts in the atmosphere. Hazardous locations are defined in the National Electrical Code (NEC) and designated by Class, Division and Group. For a better understanding of hazardous locations, or for definitions of hazardous location terminology, please refer to: <http://www.ul.com/global/eng/pages/offerings/services/hazardouslocations/>.

- **Class I** – Locations where the atmosphere may contain flammable gases or vapors in explosive or ignitable concentrations. An electric disc brake for Class I locations must be built in such a manner that any ignition of gases or vapors within the brake will not result in rupture of the enclosure or allow a flame or spark to travel from within the brake to the surrounding hazardous atmosphere.
- **Class II** – Locations with combustible dust in suspension in the atmosphere. An electric disc brake for Class II locations must be enclosed in a manner which precludes entry of ignitable dusts or exit of any arcs, sparks, or hot gases which may cause ignition of dusts suspended in the surrounding atmosphere or accumulated on the enclosure. The exterior surface temperature of the brake enclosure must be limited so that it can function at its maximum-rated duty cycle without causing dehydration or carbonization of dust that accumulates on the enclosure.
- **Divisions** – Each hazardous-location Class is also divided into two Divisions, 1 and 2. Division 1 is a normally hazardous location. Division 2 is normally not hazardous. Division 1 brakes can be used in both types of locations. **Division 2 can be used in Division 2 environments ONLY.**
- **Groups** – Class I gases and vapors are listed in four Groups A, B, C and D, based on specific properties such as maximum explosion pressure and ignition temperature. Class II airborne dusts are listed in three Groups: E, F, and G. The dust properties considered include thermal and electrical conductivity and ignition temperature.

Selection

When specifying a Stearns hazardous-location disc brake, the Class and Group designations of the hazardous atmosphere and its ignition temperature must be known. The selection table gives the hazardous atmospheres that Stearns brakes are suitable for, along

with the brake's maximum operating temperature. For more information on hazardous location responsibilities, see: <http://www.ul.com/global/eng/pages/offerings/services/hazardouslocations/>

Step 1 – Determine the Class and Group designation of the hazardous atmosphere.

Step 2 – For Class I hazardous substances, determine the ignition temperature of the explosive gas or vapor. Select a brake listed for the appropriate group with a maximum external surface temperature that does not exceed the ignition temperature of the explosive gas or vapor.

Step 3 – For Class II hazardous substances, select a brake listed for the appropriate group.

Ignition temperatures of Combustible Dusts may be found in NFPA publication NFPA 499 Recommended Practice for the Classification of Combustible Dusts and of Hazardous (Classified) Locations for Electrical Installations in Chemical Process Areas. Ignition temperatures of Flammable Liquids, Gases and Vapors may be found in NFPA publication NFPA 497 Recommended Practice for the Classification of Flammable Liquids, Gases and Vapors and of Hazardous (Classified) locations for Electrical Installations in Chemical Process Areas.

Brake Labels & Listing

Stearns brakes for use in hazardous locations are marked to show the Class, Group, and maximum Class II operating temperature (in a 40°C ambient) of the brake enclosure, as well as the minimum Class I ignition temperature of the gases or vapors to which they can be exposed.

Generally, compliance with the NEC is demonstrated by UL Listing of the product in Underwriters Laboratories Hazardous Location Equipment Directory. A label displaying the UL Listing mark and required rating information will be found on each Stearns brake to confirm the Listing.

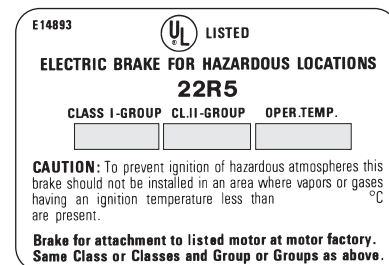

The CUL monogram will be found on Stearns hazardous-location brakes sold in Canada to confirm certification.

Stearns motor-mounted, hazardous-location electric disc brakes are Listed only when mounted directly

to a Listed hazardous-location motor of the same Class and Group at the motor manufacturer's facility, and where the combination has been accepted by UL. This procedure completes the explosion-proof assembly of the brake. However, *foot-mounted* Listed hazardous-location disc brakes are also available for coupling to a motor, and may be installed by anyone.

These brakes are listed by UL (Underwriters Laboratories, Inc.) for use in certain locations classified as hazardous. Installation and servicing must be in compliance with all existing local safety codes. All wiring and electrical connections must comply with the National Electric Code (NEC) and local electrical codes in effect at the time. For additional information see the Underwriters Laboratories (UL) website <http://www.ul.com/hazloc/codes/html>.

HazLoc inspection authorities are responsible for verifying and authorizing the use of suitably designed, manufactured and installed HazLoc equipment. When questions arise always consult the local Authority Having Jurisdiction (AHJ) for directions and approvals.

Hazardous-Location Brake Enclosures

Division 1, hazardous location brakes are typically provided with machined components, without gaskets. Series 65,300 brakes can be provided with gaskets to meet IP 55, 56 or Type 4 enclosure protection. Series 87,300 brakes can be provided with gaskets to meet IP 55, 56 or 57 enclosure protection. Series 82,300 can be provided with IP 56 protection. All Division 1 enclosures prevent flame propagation to the outside atmosphere through tortuous flame paths having controlled clearances. If the brake is used in a high humidity or low temperature environment, internal electric heaters should be used.

Division 2 hazardous location brakes are provided with an IP 55 rating. Heater and proximity switch options are limited to Division 2, Class II brakes.

Thermal Considerations

A major design requirement of hazardous-location brakes is to limit exterior surface temperature. The surface temperature of the enclosure must not exceed a specified limit as a result of heat energy created in stopping the motor and load. This NEC restriction on the exterior surface temperature limits the hazardous-location brake's ability to dissipate heat, resulting in less thermal capacity than a comparable brake with a standard or dust-tight, waterproof enclosure.

CAUTION: HAZARDOUS LOCATION BRAKES ARE INTENDED FOR NON-CYCLIC OR HOLDING PURPOSES, BUT MAY BE USED FOR STOPPING LIGHT INERTIAL LOADS.

Hazardous Location Brake Selection Table

Classification		Minimum Auto-Ignition Temperature of Atmosphere	Minimum Layer or Cloud Ignition Temperature	T Code	Brake Series Division 1	Brake Series Division 2	
Class	Group						
I	A	160°C / 320°F		T3C		56800, 87800	
	B	160°C / 320°F		T3C		56800, 87800	
	C		100°C / 212°F		T5	87300	
			135°C / 275°F	212°F	T4	82300	
			160°C / 320°F		T3C		56800, 87800
			180°C / 356°F		T3A	65300	
	D		100°C / 212°F		T5	87300	
			135°C / 275°F		T4	82300	
			160°C / 320°F		T3C		56800, 87800
			180°C / 356°F		T3A	65300	
II	E		100°C / 212°F	T5	87300		
			135°C / 275°F	T4	82300		
			165°C / 329°F	T3B	65300*		
	F		100°C / 212°F	T5	87300		
			135°C / 275°F	T4	82300		
			160°C / 320°F	T3C		56800, 87800	
			165°C / 329°F	T3B		87800	
	G		165°C / 329°F	T3B	65300		
			100°C / 212°F	T5	87300		
			135°C / 275°F	T4	82300		
			160°C / 320°F	T3C		56800, 87800	
			165°C / 329°F	T3B		87800	
			165°C / 329°F	T3B	65300		
			165°C / 329°F	T3B	65300		

NOTE: Group E available in select models only. Consult factory.

*Series 65,300-07 (Close Coupled) and 65,300-09 (fanguard mount) are Class I Group C and D, Class II Group F and G only.

Maximum exterior surface temperature is based on operation in an ambient of 104°F (40°C).

65,300; 87,300 & 82,300

These brakes rely on a thermostatic switch wired to the motor control circuit to limit the brake's enclosure surface temperature. Refer to the circuit diagram. If the brake begins to overheat, the thermostat TSW2 switch will open and interrupt the motor starter and brake solenoid current, causing the brake to set. A second thermostat TSW1 will close on Series 65,X00, or will open on Series 87,300** and 82,300** brakes. The TSW1 switch can be used to actuate alarm or warning light. This switch actuates at a lower temperature than TSW2, and will alert the equipment operator of an impending thermal overload.

**TSW1 is optional on 87,300 and 82,300 series brakes.

Circuit Diagram

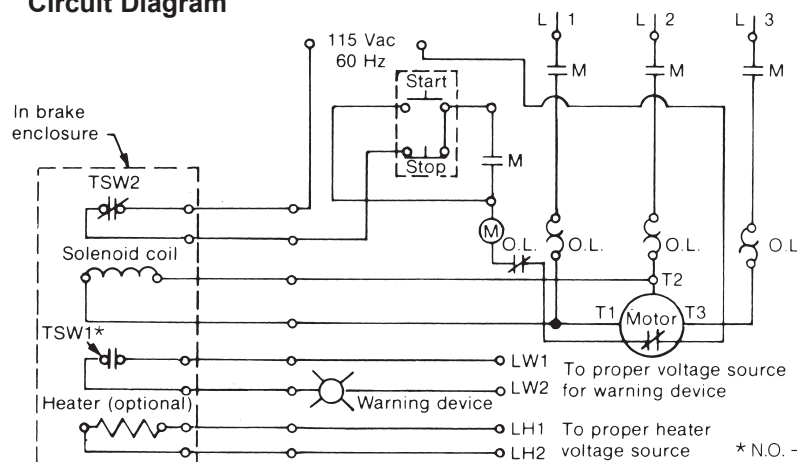

* N.O. - 65,300 brake
N.C. - 87,300 brake
& 82,300 brake

Series 65,300 (1-065-3XX-05, -07 & -09)

Division I Hazardous Location

Mounting Face: NEMA 56C, 143TC & 145TC

4.5" AK, 5.88" AJ

Static Torque: 1.5 through 15 lb-ft

Enclosure Material: Cast iron

Release Type: Knob, maintained with automatic reset

Modifications: No modification required for single disc brake vertical mounting; M21 modification standard for multi-disc brake vertical mounting. See SAB modifications section.

1-065-3XX-05 Series Close Coupled

Enclosure: UL Type 1, NEMA 7 & 9

Model Number	IP Rating	Nominal Static Torque lb-ft (Nm)	Dimensions in Inches (mm)		Weight lbs (kg)
			SL Max.	SL Min.	
1-065-311-05-XXX	IP 40	1.5 (2)	2.95 (74.93)	2.25 (57.15)	38 (17.2)
1-065-321-05-XXX	IP 40	3 (4)	2.95 (74.93)	2.25 (57.15)	38 (17.2)
1-065-331-05-XXX	IP 40	6 (8)	2.95 (74.93)	2.25 (57.15)	40 (18.1)
1-065-351-05-XXX	IP 40	10 (14)	2.95 (74.93)	2.31 (58.67)	45 (20.4)
1-065-361-05-XXX	IP 40	15 (20)	2.95 (74.93)	2.31 (58.67)	45 (20.4)

1-065-3XX-07 Close Coupled

Enclosure: UL Type 4, NEMA 7 & 9

Model Number	IP Rating	Static Torque (lb-ft)	Weight lbs (kg)
1-065-312-07-XXX	IP 56	1.5	52 (23.6)
1-065-322-07-XXX	IP 56	3	52 (23.6)
1-065-332-07-XXX	IP 56	6	57 (25.8)
1-065-352-07-XXX	IP 56	10	57 (25.8)
1-065-362-07-XXX	IP 56	15	57 (25.8)

Engineering Specifications

Nominal Static Torque lb-ft (Nm)	No. of Friction Discs	Coil Size	Maximum Solenoid Cycle Rate ^① cycles/min	Thermal Capacity ^② hp-sec/min (watts)	Inertia (Wk ²) lb-ft ² (kgm ² x 10 ⁻⁴)
1.5 (2)	1	4	40	2 (25)	.008 (3.36)
3 (4)	1	4	40	2 (25)	.008 (3.36)
6 (8)	1	4	40	2 (25)	.008 (3.36)
10 (14)	2	4	40	2 (25)	.014 (5.58)
15 (20)	2	4	40	2 (25)	.014 (5.58)

① Maximum solenoid cycle rate is 40 cycles/min., based on ambient temperature of 72°F (22°C) with 50% duty cycle. Does not relate to brake cycle rate (see thermal capacity).

② Thermal capacity rating is 2 hp-sec/min. (25 watts) based on ambient temperature of 72°F (22°C), stop time of one second or less, with no heat absorbed from motor. Derate thermal capacity by 25% for vertical mounting. Refer to selection procedure section.

Current Ratings (amperes)

Coil Size	Current	Voltage: 60 Hz						Voltage: 50 Hz		
		115 Vac	200 Vac	230 Vac	400 Vac	460 Vac	575 Vac	110 Vac	220 Vac	380 Vac
4	Inrush Holding	3.6 .3	2.1 .2	1.8 .2	1.1 .08	.9 .08	.7 .06	4.1 .3	2.1 .2	.9 .08

Features

- Spring-set electrically released
- Manual wear adjustment
- Coil insulation: Class 180(H)
- NO interlock & NC warning (optional) thermostats
- Maximum speed: horizontal 5000 rpm, vertical 3600 rpm

Ordering & Identification Information

Example of a complete part number:

1-065-351-05-BFB — Lead wire position (external left)
 — 230 Vac
 — 5/8 bore and 3/16 x 3/32 keyway
 — Series: (Current Design = 05)
 (Fanguard Mount = 09)

Hub Selection

Character	Bore (in.)	Keyway** (in. x in.)
A*	5/8	1/8 x 1/16
B	5/8	3/16 x 3/32
C	3/4	3/16 x 3/32
D	7/8	3/16 x 3/32
K	1/2	1/8 x 1/16
maximum allowable bore	1.0 in. (22.40 mm)	

* These bores are non-standard.

** Keyseats made to ANSI B17.1 standard

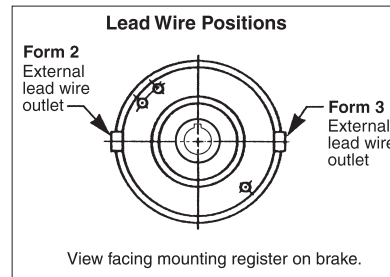

Character	Lead Wire Position
B	Form 2
C	Form 3

SAB Voltage Chart

Voltage Character in Brake P/N	Coil Type ⁴	Nominal Voltage ^{1,2} [VAC]						
		Wiring Configuration #1		Wiring Configuration #2				
		@60Hz	@50Hz	@60Hz	@50Hz			
B	1	115	95	N/A				
D		132	110					
E		200	165					
F		230	190					
H		264	220					
L		460	380					
M		498	415					
N		575	480					
O		2	264			220	132	110
P			230³			190	115	95
Q	460		380	230³	190			
R	400		330	200	165			

1. Bold text is the more common voltage and frequency combination.

2. Operating Voltage Range is ± 10%

3. If it's a Size 4 coil, the coil voltage is 208-230 (with a minimum operating voltage of 200VAC).

4. 1=AC single voltage; 2=AC dual voltage.

AC Single Voltage

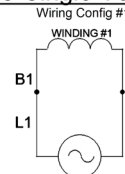

AC Dual Voltage

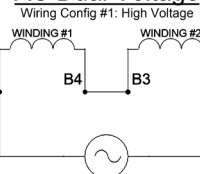

AC Dual Voltage

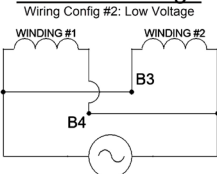

Series 65,300 Continued

Division I Hazardous Location

1-065-3XX-05 Series

IP Rating: 40

Enclosure Type: UL Type 1, NEMA 7, NEMA 9

Mounting: 1-065-3XX-05 Series hazardous location motor mounted brake is used for mounting close coupled (directly) to the motor end bell. If the brake is to be mounted to a motor fanguard, or if a motor frame adapter is incorporated, it is recommended that Series 1-065-3XX-09 be used, as it provides additional bearing support for the longer shaft that is required. The acceptability of the brake and motor combination must be determined by Underwriters Laboratories Inc.

Certified: Series 65,300-05 (1-065-3XX-05) USL/CNL File E-14893 for Class I Group C and D; Class II Group E, F and G; Class I Zone 1 Group IIA and IIB

Modifications: See SAB modifications section.

Installation & Service Instructions: P/N 8-078-925-13 Rev. C & D brakes

Parts List: P/N 8-078-913-13 Rev. C & D brakes

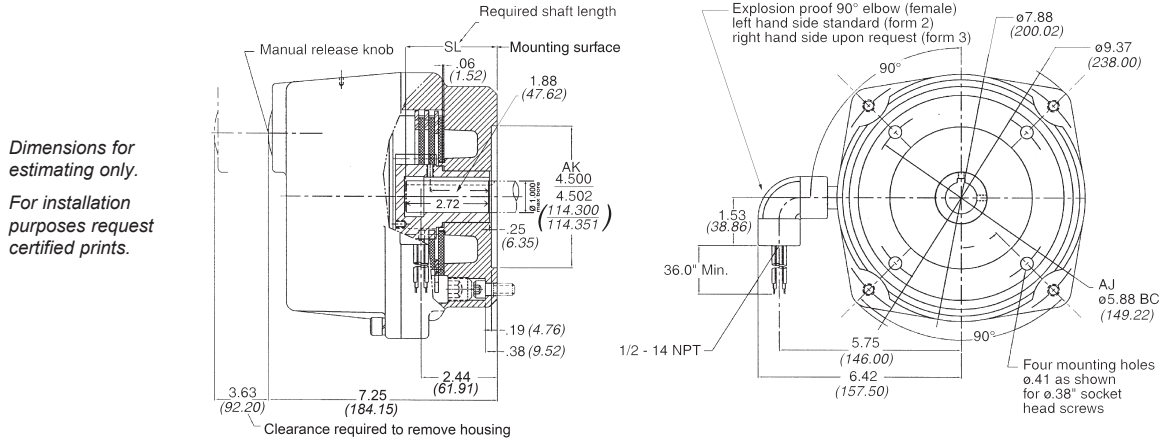

1-065-3XX-07 Series

IP Rating: 56

Enclosure Type: UL Type 4, NEMA 7, NEMA 9

Mounting: 1-065-3XX-07 Series hazardous location motor mounted brake is used for mounting close coupled (directly) to the motor end bell. If the brake is to be mounted to a motor fanguard, or if a motor frame adapter is incorporated, it is recommended that Series 1-065-3XX-09 be used, as it provides additional bearing support for the longer shaft that is required. The acceptability of the brake and motor combination must be determined by Underwriters Laboratories Inc.

Certified: Series 65,300-07 (1-065-3XX-07) USL/CNL File E-14893 for Class I Group C and D; Class II Group F and G; Class I Zone 1 Group IIA and IIB

Modifications: See SAB modifications section.

Installation & Service Instructions: P/N 8-078-925-09

Parts List: P/N 8-078-913-09

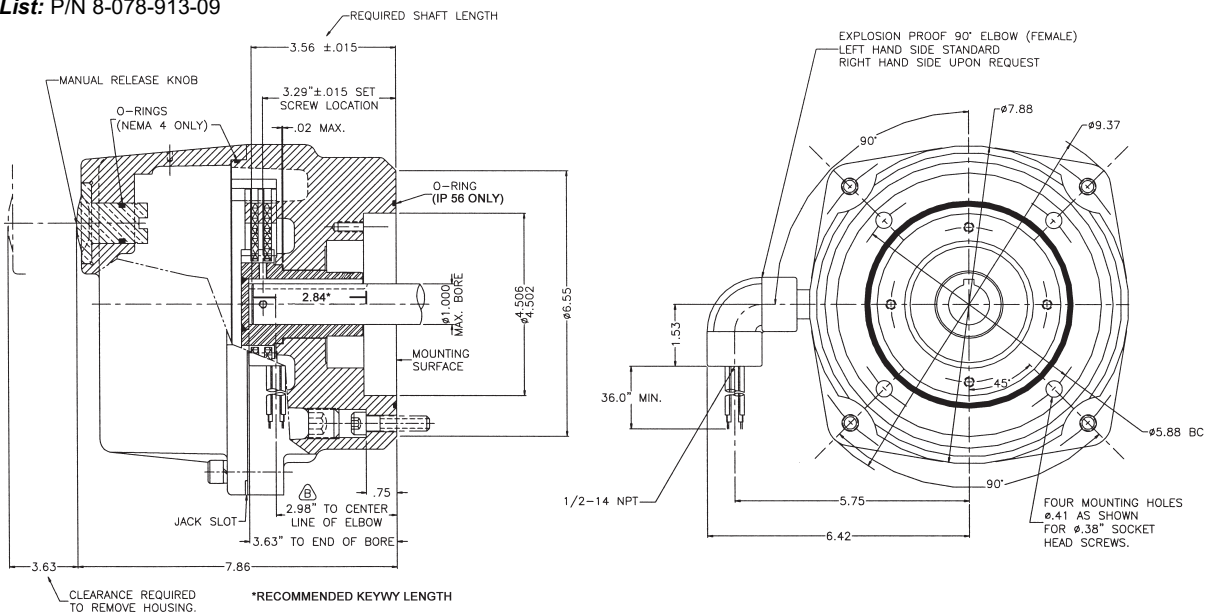

Note: 65,300 Series close-coupled brakes (-07) must be mounted directly to motor endbell.

Series 65,300 Continued

Division I Hazardous Location

1-065-3XX-09 Fan-Guard Mount

Enclosure: UL Type 1, NEMA 7 & 9

Model Number	IP Rating	Static Torque lb-ft (Nm)	Weight lbs (kg)
1-065-311-09-XXX	IP 40	1.5 (2)	52 (23.6)
1-065-321-09-XXX	IP 40	3 (4)	52 (23.6)
1-065-331-09-XXX	IP 40	6 (8)	57 (25.8)
1-065-351-09-XXX	IP 40	10 (14)	57 (25.8)
1-065-361-09-XXX	IP 40	15 (20)	57 (25.8)

1-065-3XX-09 Series

IP Rating: 40

Enclosure Type: UL Type 1, NEMA 7, NEMA 9

Mounting: 1-065-3X1-09 Series hazardous location motor mounted brake is recommended for mounting to a motor fanguard or for use with a motor frame adapter. The acceptability of the brake and motor combination must be determined by Underwriters Laboratories Inc.

Certified: 65,300-09 (1-065-3XX-09)

USL/CNL File E-14893 for Class I Group C and D; Class II Group F and G; Class I Zone 1 Group IIA and IIB

Modifications: See SAB modifications section.

Installation & Service Instructions: P/N 8-078-925-09

Parts List: P/N 8-078-913-09

Dimensions for estimating only.

For installation purposes request certified prints.

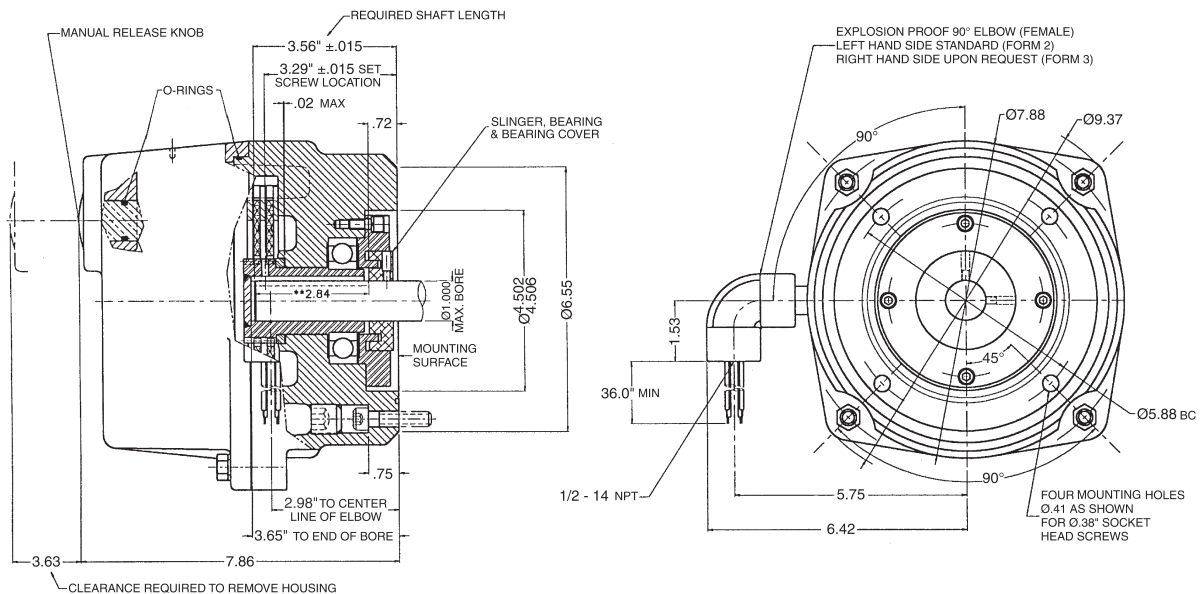

**Maximum keyway length for fanguard mount (1-065-3XX-09)

Series 87,300-00 & 87,300-02 (1-087-3XX) Motor Mounted Division I Hazardous Location Mounting Face: NEMA 182TC, 184TC, 213TC, 215TC, 254TC & 256TC 8.5" AK, 7.25" AJ

Static Torque: 10 through 105 lb-ft

Enclosure Material: Cast iron

Release Type: Knob

Modifications: Modification required for vertical above mounting. For vertical below, modification required on 50-105 lb-ft. See SAB modification section.



Features

- Spring-set electrically released
- Self-adjusting design
- Coil insulation: Class 180(H)
- NC thermostat
- Maximum speed: horizontal 4000 rpm, vertical 3000 rpm
- Lead wire length: 36 inches
- ABS type approval certified

Brake set and release times in milliseconds, when brake and motor are switched separately (for T1/T2 definitions, see set and release times section):

Static Torque	Coil Size	T1	T2
10, 15, 25, 50	5 & 6	42	20
35, 75, 105	8	48	20

Series 87,300-00

IP Rating: 40, 55, 57

Enclosure Type: UL Type 1, UL Type 4 (brake must be mounted close coupled to motor endbell - a motor frame adapter may be included), NEMA 7, NEMA 9

Mounting: 1-087-3XX-00 Series hazardous location motor mounted brake is recommended for mounting close coupled (directly) to the motor end bell. If the brake is to be mounted to a motor fanguard, or if a motor frame adapter is incorporated, it is recommended that Series 1-087-3XX-02 be used, as it provides additional bearing support for the longer shaft that is required. The acceptability of the brake and motor combination must be determined by Underwriters Laboratories Inc.

Certified: UL Listed File E-14893 for Class I Group C and D; Class II Group F and G

Installation & Service Instructions: P/N 8-078-927-03

Parts List: P/N 8-078-917-03 for IP 40 8-078-917-23 for IP 55

Outline Drawing for IP 40 & 55

Dimensions for estimating only. For installation purposes request certified prints.

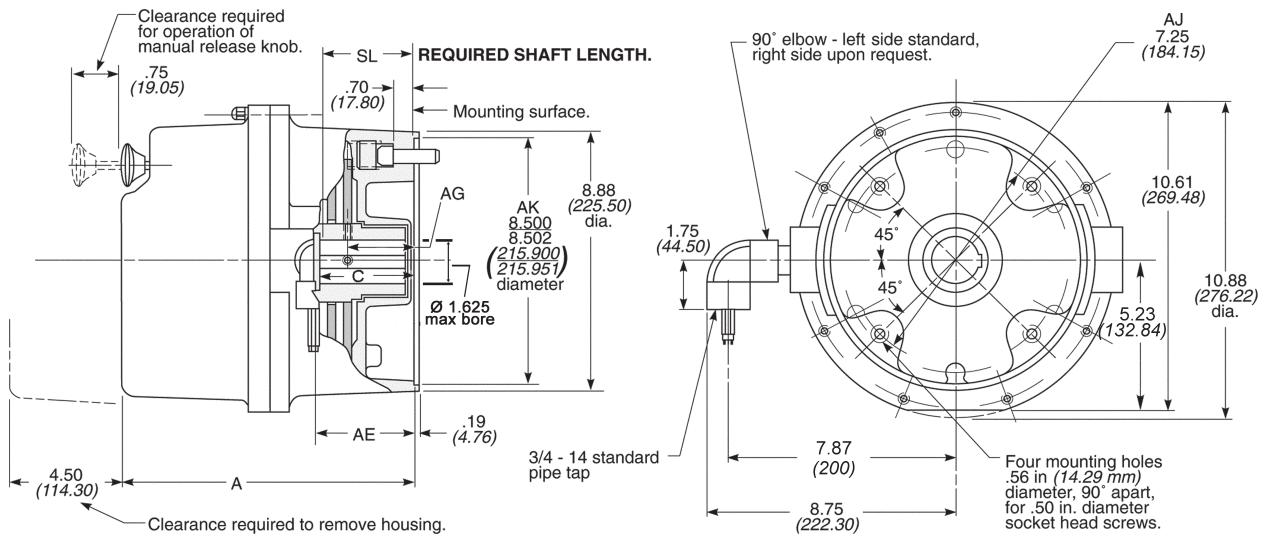

IP 40 & 55 Dimensions; Enclosure: NEMA 7 & 9

Model Number	IP Rating	Enclosure	Nominal Static Torque lb-ft (Nm)	Dimensions in Inches (Dimensions in Millimeters)					Weight lbs (kg)
				A	AE	AG	C	SL ± .05"	
1-087-311-00-XXX	IP 40	UL Type 1	10	9.34	3.22	2.25	2.76	2.56	62
1-087-314-00-XXX	IP 55	UL Type 4	(14)	(237.33)	(81.79)	(57.2)	(70.1)	(65.0)	(28.0)
1-087-321-00-XXX	IP 40	UL Type 1	15	9.34	3.22	2.25	2.76	2.56	63
1-087-324-00-XXX	IP 55	UL Type 4	(20)	(237.33)	(81.79)	(57.2)	(70.1)	(65.0)	(28.6)
1-087-331-00-XXX	IP 40	UL Type 1	25	9.34	3.22	2.25	2.76	2.56	63
1-087-334-00-XXX	IP 55	UL Type 4	(34)	(237.33)	(81.79)	(57.2)	(70.1)	(65.0)	(28.6)
1-087-341-00-XXX	IP 40	UL Type 1	35	9.34	3.22	2.25	2.76	2.56	63
1-087-344-00-XXX	IP 55	UL Type 4	(47)	(237.33)	(81.79)	(57.2)	(70.1)	(65.0)	(28.6)
1-087-351-00-XXX	IP 40	UL Type 1	50	9.34	3.22	2.25	2.76	2.56	64
1-087-354-00-XXX	IP 55	UL Type 4	(68)	(237.33)	(81.79)	(57.2)	(70.1)	(65.0)	(29.0)
1-087-361-00-XXX	IP 40	UL Type 1	75	9.34	3.22	2.25	2.76	2.56	65
1-087-364-00-XXX	IP 55	UL Type 4	(102)	(237.33)	(81.79)	(57.2)	(70.1)	(65.0)	(29.5)
1-087-381-00-XXX	IP 40	UL Type 1	105	10.34	4.22	2.75	3.73	3.53	72
1-087-384-00-XXX	IP 55	UL Type 4	(142)	(262.73)	(107.19)	(69.9)	(94.7)	(89.7)	(32.7)

Series 87,300-00 Continued

Division I Hazardous Location

Outline Drawing for IP 57

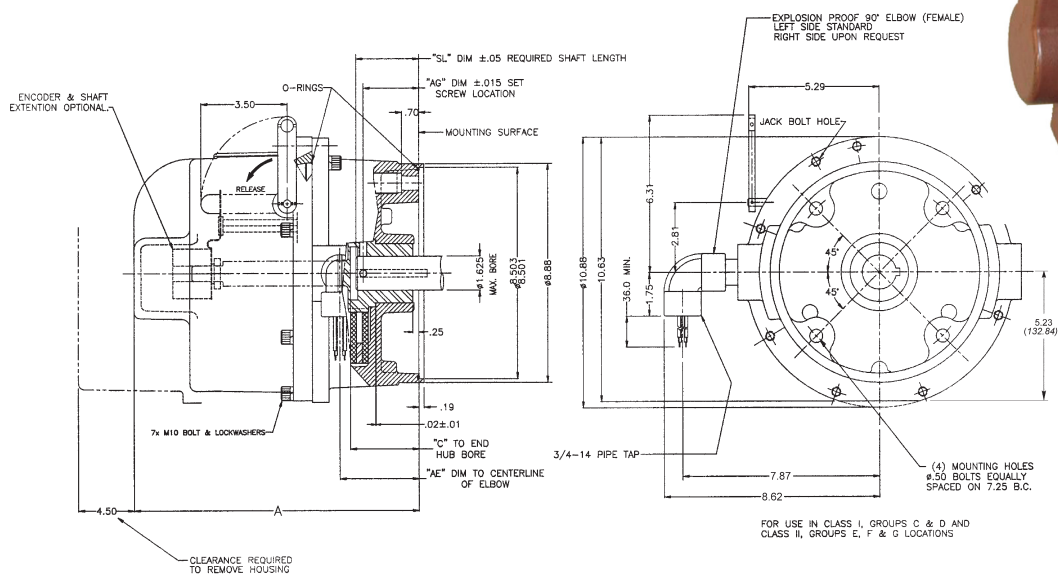

IP 57 Dimensions

Enclosure: UL Type 4, NEMA 7 & 9

Model Number	IP Rating	Nominal Static Torque lb-ft (Nm)	Dimensions in Inches (Dimensions in Millimeters)					Wt. Lbs (kg)
			A	C	SL	AE	G	
1-087-318-00-XXX	IP 57	10 (14)	11.57	2.76	2.56	3.22	2.25	63 (28.6)
1-087-328-00-XXX	IP 57	15 (20)	11.57	2.76	2.56	3.22	2.25	64 (29)
1-087-338-00-XXX	IP 57	25 (34)	11.57	2.76	2.56	3.22	2.25	64 (29)
1-087-348-00-XXX	IP 57	35 (47)	11.57	2.76	2.56	3.22	2.25	64 (29)
1-087-358-00-XXX	IP 57	50 (68)	11.57	2.76	2.56	3.22	2.25	65 (29.5)
1-087-368-00-XXX	IP 57	75 (102)	11.57	2.76	2.56	3.22	2.25	66 (30)
1-087-388-00-XXX	IP 57	105 (142)	12.57	3.73	3.53	4.22	2.75	73 (33.1)

Series 87,300-02 Continued

(1-087-3XX) Motor Mounted

Division I Hazardous Location

Series 87,300-02

IP Rating: 40, 55, 56

Enclosure Type: UL Type 1, UL Type 4, NEMA 7, NEMA 9

Mounting: 1-087-3XX-02 Series hazardous location motor mounted brake is recommended for mounting to a motor fanguard, or for use with a motor frame adapter. The acceptability of the brake and motor combination must be determined by Underwriters Laboratories Inc.

Certified: UL Listed File E-14893 for Series 87,300-02 for Class I Group C and D; Class II Group E, F and G

Modifications: See SAB modifications section.

Installation & Service Instructions: P/N 8-078-927-05

Parts List: P/N 8-078-917-05

Outline Drawing for IP 40 & 55

Dimensions for estimating only.
For installation purposes request certified prints.

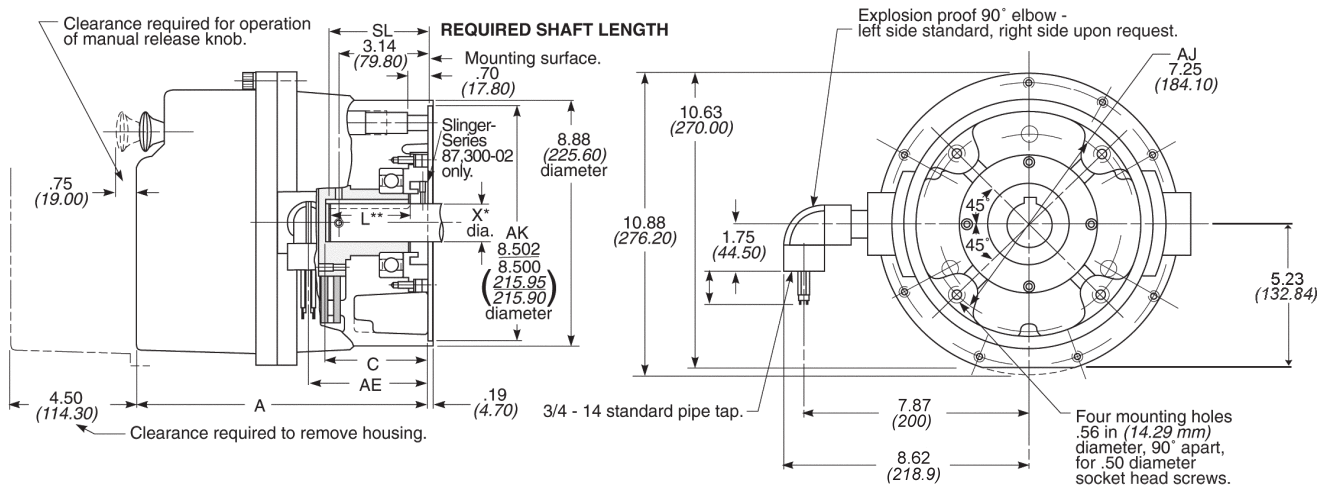

*X max diameter 1.625 in./ min. .875 in.

**L is the maximum keyway slot.

IP 40 & 55 Dimensions

Enclosure: NEMA 7 & 9

Model Number	IP Rating	Enclosure	Nominal Static Torque lb-ft (Nm)	Dimensions in Inches (Dimensions in Millimeters)					Weight lbs (kg)
				A	AE	C	SL ± .05"	L** Max.	
1-087-311-02-XXX	IP 40	UL Type 1	10	10.34	4.22	3.65	3.50	2.89	90
1-087-314-02-XXX	IP 55	UL Type 4	(14)	(262.60)	(107.19)	(92.70)	(88.90)	(73.40)	(41)
1-087-321-02-XXX	IP 40	UL Type 1	15	10.34	4.22	3.65	3.50	2.89	90
1-087-324-02-XXX	IP 55	UL Type 4	(20)	(262.60)	(107.19)	(92.70)	(88.90)	(73.40)	(41)
1-087-331-02-XXX	IP 40	UL Type 1	25	10.34	4.22	3.65	3.50	2.89	90
1-087-334-02-XXX	IP 55	UL Type 4	(34)	(262.60)	(107.19)	(92.70)	(88.90)	(73.40)	(41)
1-087-341-02-XXX	IP 40	UL Type 1	35	10.34	4.22	3.65	3.50	2.89	90
1-087-344-02-XXX	IP 55	UL Type 4	(47)	(262.60)	(107.19)	(92.70)	(88.90)	(73.40)	(41)
1-087-351-02-XXX	IP 40	UL Type 1	50	10.34	4.22	3.65	3.50	2.89	90
1-087-354-02-XXX	IP 55	UL Type 4	(68)	(262.60)	(107.19)	(92.70)	(88.90)	(73.40)	(41)
1-087-361-02-XXX	IP 40	UL Type 1	75	10.34	4.22	3.65	3.50	2.89	90
1-087-364-02-XXX	IP 55	UL Type 4	(102)	(262.60)	(107.19)	(92.70)	(88.90)	(73.40)	(41)
1-087-381-02-XXX	IP 40	UL Type 1	105	10.84	4.72	4.11	3.75	3.14	96
1-087-384-02-XXX	IP 55	UL Type 4	(142)	(275.10)	(119.10)	(104.40)	(95.30)	(79.70)	(43.5)

Side release is also available in a fanguard mount design. Consult Stearns and request drawing no. 1-087-305-2D.

Series 87,300-02 Continued

Division I Hazardous Location

Outline Drawing for IP 56

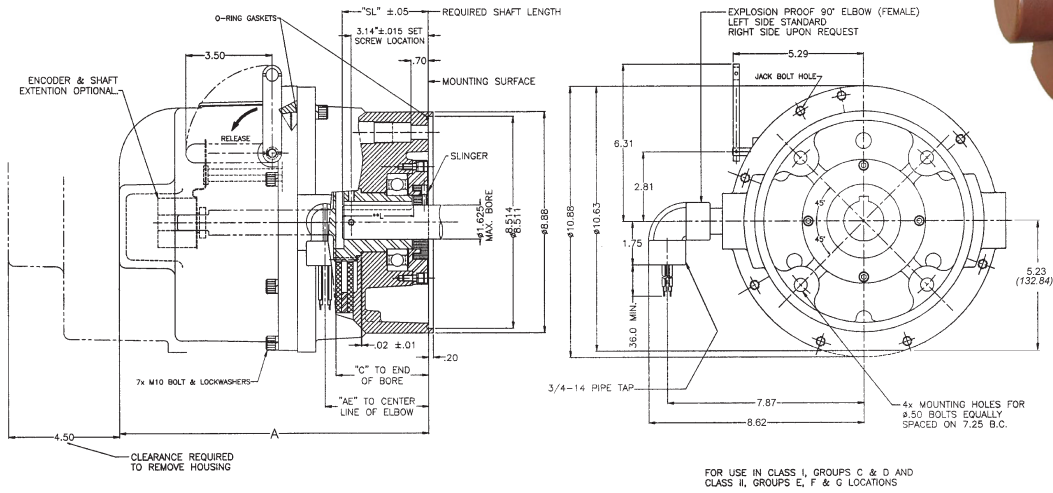

IP 56 Dimensions

Enclosure: UL Type 4, NEMA 7 & 9

Model Number	IP Rating	Nominal Static Torque lb-ft (Nm)	Dimensions in Inches (Dimensions in Millimeters)					Wt. Lbs (kg)
			A	C	L**	SL	AE	
1-087-315-02-XXX	IP 56	10 (14)	12.60	3.65	2.89	3.50	4.22	91 (41.3)
1-087-325-02-XXX	IP 56	15 (20)	12.60	3.65	2.89	3.50	4.22	91 (41.3)
1-087-335-02-XXX	IP 56	25 (34)	12.60	3.65	2.89	3.50	4.22	91 (41.3)
1-087-345-02-XXX	IP 56	35 (47)	12.60	3.65	2.89	3.50	4.22	91 (41.3)
1-087-355-02-XXX	IP 56	50 (68)	12.60	3.65	2.89	3.50	4.22	91 (41.3)
1-087-365-02-XXX	IP 56	75 (102)	12.60	3.65	2.89	3.50	4.22	91 (41.3)
1-087-385-02-XXX	IP 56	105 (142)	13.10	4.11	3.14	3.75	4.72	97 (44)

**L is the maximum keyway slot.

Series 87,300-00 (1-087-3XX)

Division I Hazardous Location

Mounting: Foot Mounted

Static Torque: 10 through 105 lb-ft

IP Rating: 40

Enclosure Material: Cast iron

Enclosure Type: UL Type 1, UL Type 4, NEMA 7, NEMA 9

Release Type: Knob

Mounting: 1-087-3X2-00 Series hazardous location foot mounted brake does not require assembly to the motor to complete the hazardous location enclosure.

Modifications: See SAB modifications section.

Installation & Service Instructions:
P/N 8-078-927-03

Parts List: P/N 8-078-917-03



Features

- Spring-set electrically released
- Self-adjusting design
- Coil insulation: Class 180(H)
- NC thermostat
- Maximum speed: horizontal 4000 rpm
- UL Listed File E-14893 for Class I Group C and D; Class II Group F and G certified
- Lead wire length: 36 inches
- ABS type approval certified

Brake set and release times in milliseconds, when brake and motor are switched separately (for T1/T2 definitions, see set and release times section):

Static Torque	Coil Size	T1	T2
10, 15, 25, 50	5 & 6	42	20
35, 75, 105	8	48	20

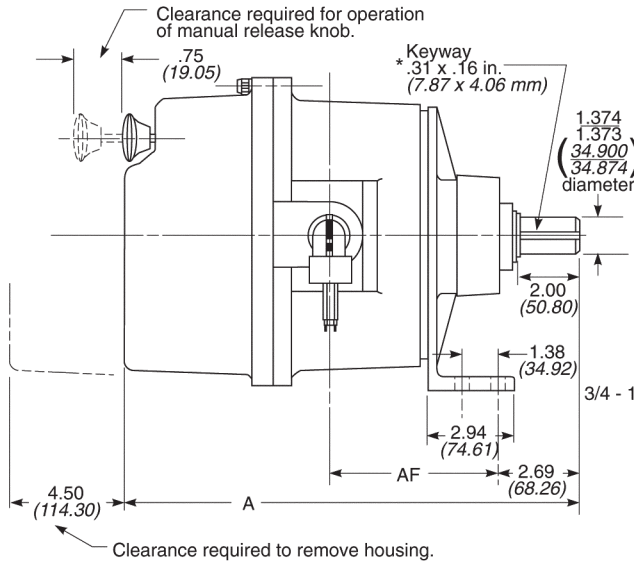

* Keyseats made to ANSI B17.1 standard

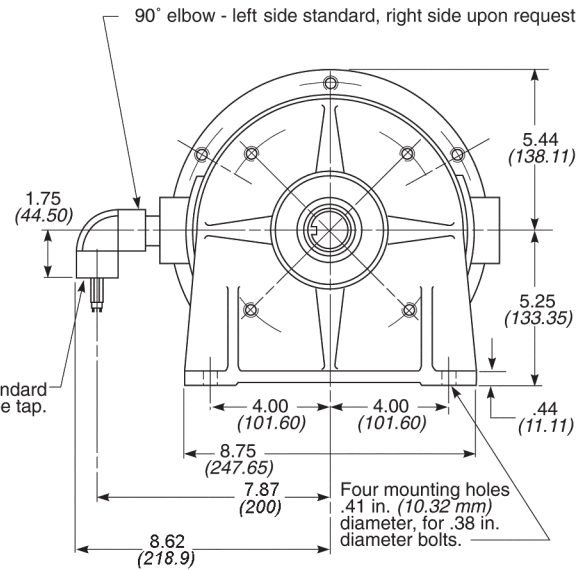

Dimensions for estimating only. For installation purposes request certified prints.

Dimensions

Model Number	IP Rating	Enclosure	Nominal Static Torque lb-ft (Nm)	Dimensions in Inches (Dimensions in Millimeters)		Weight (lbs) (kg)
				A	AF	
1-087-312-00-XX	IP 40	UL Type 1	10 (14)	14.66 (372.27)	5.85 (148.59)	82 (37.2)
1-087-322-00-XX	IP 40	UL Type 1	15 (20)	14.66 (372.27)	5.85 (148.59)	83 (37.6)
1-087-332-00-XX	IP 40	UL Type 1	25 (34)	14.66 (372.27)	5.85 (148.59)	83 (37.6)
1-087-342-00-XX	IP 40	UL Type 1	35 (47)	14.66 (372.27)	5.85 (148.59)	83 (37.6)
1-087-352-00-XX	IP 40	UL Type 1	50 (68)	14.66 (372.27)	5.85 (148.59)	84 (38.1)
1-087-362-00-XX	IP 40	UL Type 1	75 (102)	14.66 (372.27)	5.85 (148.59)	85 (38.5)
1-087-382-00-XX	IP 40	UL Type 1	105 (142)	15.66 (397.67)	6.85 (173.99)	92 (41.7)

Series 87,300 Continued

Division I Hazardous Location

Specifications & Ordering Information

for Series 87,300-00 (1-087-3XX-00) & Series 87,300-02 (1-087-3XX-02)

Engineering Specifications

Nominal Static Torque lb-ft (Nm)	No. of Friction Discs	Coil Size	Maximum Solenoid Cycle Rate ^① cycles/min	Thermal Capacity ^② hp-sec./min (watts)	Inertia (Wk ²) lb-ft ² (kgm ² x 10 ⁻⁴)
10 (14)	1	5	30	15 (187)	.056 (23.68)
15 (20)	1	6	25	15 (187)	.056 (23.68)
25 (34)	1	6	25	15 (187)	.056 (23.68)
35 (47)	1	8	20	15 (187)	.056 (23.68)
50 (68)	2	6	25	15 (187)	.089 (37.56)
75 (102)	2	8	20	15 (187)	.089 (37.56)
105 (142)	3	8	20	15 (187)	.127 (53.64)

- ① Maximum solenoid cycle rate is based on ambient temperature of 72°F (22°C) with 50% duty cycle. Does not relate to brake cycle rate (see thermal capacity).
- ② Thermal capacity rating is based on ambient temperature of 104°F (40°C), stop time of one second or less, with no heat absorbed from motor. Derate thermal capacity by 25% for vertical mounting. Refer to selection procedure section.

Current Ratings (amperes)

Coil Size	Current	Voltage: 60 Hz					Voltage: 50 Hz				
		115 VAC	200 VAC	230 VAC	400 VAC	460 VAC	575 VAC	110 VAC	220 VAC	380 VAC	
5	Inrush	7.5	4.3	3.7	2.2	1.9	1.5	5.4	4.0	1.9	
	Holding	.5	.3	.2	.1	.1	.09	.3	.25	.1	
6	Inrush	13.0	7.5	6.4	3.7	3.2	2.6	9.4	5.6	3.2	
	Holding	.6	.4	.3	.2	.2	.1	.5	.3	.2	
8	Inrush	17.6	10.3	8.8	5.0	4.2	3.5	15.4	7.7	4.2	
	Holding	1.2	.7	.6	.3	.3	.24	.1	.5	.3	

Motor Frame Adapters

WARNING! Before selecting an adapter to mount a brake on a larger motor frame, the torque and thermal capacity required by the application should be determined as shown in the selection procedure section. A larger motor may indicate a requirement for greater thermal capacity than the brake is designed for. The brake selection must be matched to the motor and application requirements, before use of an adapter is considered.

Consult the factory.

Ordering & Identification Information

The following example and tables provide information for selecting the appropriate three-letter suffix when ordering a Stearns brake.

Example of a complete part number: 1-087-341-02-ELC ——— Lead wire position (external right)

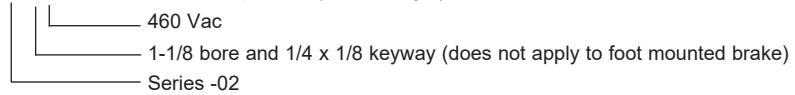

SAB Voltage Chart

Voltage Character in Brake P/N	Coil Type ⁴	Nominal Voltage ^{1,2} [VAC]			
		Wiring Configuration #1		Wiring Configuration #2	
		@60Hz	@50Hz	@60Hz	@50Hz
B	1	115	95	N/A	
D		132	110		
E		200	165		
F		230	190		
H		264	220		
L		460	380		
M		498	415		
N		575	480		
O	2	264	220	132	110
P		230³	190	115	95
Q		460	380	230³	190
R		400	330	200	165

Hub Selection

Character	Bore (in.)	Keyway* (in. x in.)
D	7/8	3/16 x 3/32
E	1-1/8	1/4 x 1/8
F	1-1/4	1/4 x 1/8
G	1-3/8	5/16 x 5/32
H	1-5/8	3/8 x 3/16
maximum allowable bore	1.625 in.	

*Keyseats made to ANSI B17.1 standard

Character	Lead Wire Position
B	Form 2
C	Form 3

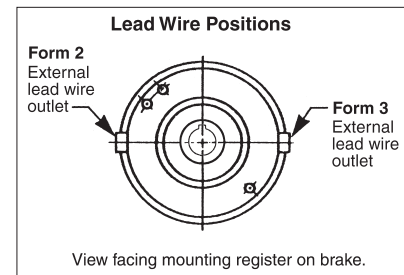

- Bold text is the more common voltage & frequency combination.
- Operating Voltage Range is ± 10%
- If it's a Size 4 coil, the coil voltage is 208-230 (with a minimum operating voltage of 200VAC).
- 1=AC single voltage; 2=AC dual voltage.

AC Single Voltage

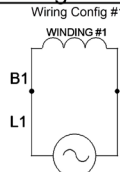

AC Dual Voltage

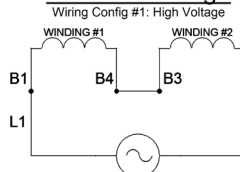

AC Dual Voltage

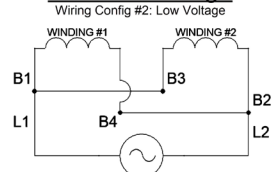

Series 82,300 (1-082-3XX) Motor Mounted

Division I Hazardous Location

Mounting Face: NEMA 324 & 326 TC, TSC, NEMA 364 & 365 TC, TSC, NEMA 404 & 405 TC, TSC 12.5" AK, 11.0" AJ

Static Torque: 125 through 330 lb-ft

IP Rating: 40, 56

Enclosure Material: Cast iron

Enclosure Type: UL Type 1, UL Type 4, NEMA 7, NEMA 9

Release Type: Side lever

Modification: Modification required for vertical mounting. See SAB modification section.

Features

- Self-adjusting design
- Coil insulation: Class 180(H)
- NC thermostat
- Spring-set electrically released
- Lead wire length: 36 inches
- Maximum speed: 3600 rpm horizontal, 2400 rpm vertical
- UL Listed File E-14893 for Class I Group C and D; and Class II Group E, F and G certified
- ABS type approval certified

1-082-3XX-00 Series Close Coupled Enclosure: UL Type 1 & 4, NEMA 7 & 9

Model Number	IP Rating	Enclosure	Nominal Static Torque lb-ft (Nm)
1-082-315-00	IP 40	UL Type 1	125
1-082-314-00	IP 56	UL Type 4	(169)
1-082-325-00	IP 40	UL Type 1	175
1-082-324-00	IP 56	UL Type 4	(237)
1-082-335-00	IP 40	UL Type 1	230
1-082-334-00	IP 56	UL Type 4	(312)
1-082-345-00	IP 40	UL Type 1	330
1-082-344-00	IP 56	UL Type 4	(447)

1-082-3X4-02 Series Fanguard Mount¹ Enclosure UL Type 4, NEMA 7 & 9

Model Number	IP Rating	Enclosure	Nominal Static Torque lb-ft (Nm)
1-082-314-02	IP 56	UL Type 4	125 (169)
1-082-324-02	IP 56	UL Type 4	175 (237)
1-082-334-02	IP 56	UL Type 4	230 (312)
1-082-344-02	IP 56	UL Type 4	330 (447)

¹See mining brakes: MSHA certified series 1-082-3X4-06

1-082-3X6-00 Series Foot Mounted Enclosure UL Type 4, NEMA 7 & 9

Model Number	IP Rating	Enclosure	Nominal Static Torque lb-ft (Nm)
1-082-316-00	IP 56	UL Type 4	125 (169)
1-082-326-00	IP 56	UL Type 4	175 (237)
1-082-336-00	IP 56	UL Type 4	230 (312)
1-082-346-00	IP 56	UL Type 4	330 (447)

Motor Frame Adapters

Adapters are available for mounting to 182TC-256TC, 284-286TC, and 444-445TSC motor frames. See Series 82,000 for details.

Engineering Specifications

Nominal Static Torque lb-ft (Nm)	No. of Friction Discs	Coil Size	Coil Strength	Maximum Solenoid Cycle Rate ^① cycles/min	Thermal Capacity ^② hp-sec/min (watts)	Inertia (Wk ²) lb-ft ² (kgm ² x 10 ⁻⁴)
125 (169)	2	9	3	15	10 (124)	.228 (95.76)
175 (237)	2	9	3	15	10 (124)	.228 (95.76)
230 (312)	3	9	3	15	10 (124)	.317 (133.14)
330 (447)	3	9	4	13	10 (124)	.317 (133.14)

- ① Maximum solenoid cycle rate is based on ambient temperature of 72°F (22°C) with 50% duty cycle. Does not relate to brake cycle rate (see thermal capacity).
- ② Thermal capacity rating is based on ambient temperature of 72°F (22°C), stop time of one second or less, with no heat absorbed from motor. Refer to selection procedure section.

Ordering & Identification Information

Example of a complete part number:

1-082-314-00-FNB _____ Lead wire position (external left)
575 Vac

_____ 1-5/8 bore and 3/8 x 3/16 keyway
Series : (Motor mount = 00)
Fanguard Mount = 02)

Hub Selection

Character	Bore (in.)	Keyway** (in. x in.)
A	1-1/8	1/4 x 1/8
C	1-3/8	5/16 x 5/32
D	1-1/2	3/8 x 3/16
F	1-5/8	3/8 x 3/16
H	1-3/4	3/8 x 3/16
J	1-7/8	1/2 x 1/4
L*	2	1/2 x 1/4
N	2-1/8	1/2 x 1/4
maximum allowable bore	2.125 in. (53.975 mm)	

*These bores are non-standard.

**Keyseats made to ANSI B17.1 standard.

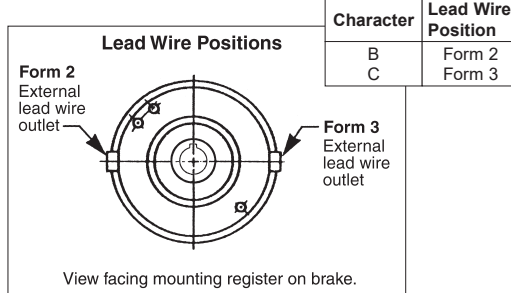

Current Ratings (amperes) 82,300 Motor Mounted & Foot Mounted

Coil Size	Coil Strength	Voltage: 60 Hz						
		Current	115 VAC	200 VAC	230 VAC	400 VAC	460 VAC	575 VAC
9	3	Inrush	44.0	25.4	22.0	12.7	11.1	8.8
		Holding	1.6	.9	.8	.5	.4	.3
		Voltage: 50 Hz						
		Current	110 VAC	220 VAC	380 VAC			
9	4	Inrush	32.1	16.0	11.1			
		Holding	1.2	.6	.4			
		Voltage: 60 Hz						
		Current	115 VAC	200 VAC	230 VAC	400 VAC	460 VAC	575 VAC
9	4	Inrush	50.0	28.0	25.0	14.0	12.5	10.0
		Holding	2.2	1.3	1.1	.6	.6	.4
		Voltage: 50 Hz						
		Current	110 VAC	220 VAC	380 VAC			
9	4	Inrush	36.0	24.0	12.5			
		Holding	1.6	.9	.6			

SAB Voltage Chart

Voltage Character in Brake P/N	Coil Type ⁴	Nominal Voltage ^{1,2} [VAC]					
		Wiring Configuration #1		Wiring Configuration #2			
		@60Hz	@50Hz	@60Hz	@50Hz		
B	1	115	95	N/A			
D		132	110				
E		200	165				
F		230	190				
H		264	220				
L		460	380				
M		498	415				
N		575	480				
O		264	220			132	110
P		230³	190			115	95
Q		460	380			230³	190
R	400	330	200	165			

1. Bold text is the more common voltage & frequency combination.
2. Operating Voltage Range is ± 10%
3. If it's a Size 4 coil, the coil voltage is 208-230 (with a minimum operating voltage of 200VAC).
4. 1=AC single voltage; 2=AC dual voltage.

AC Single Voltage

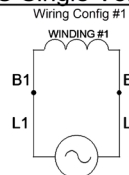

AC Dual Voltage

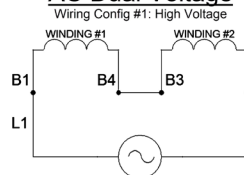

AC Dual Voltage

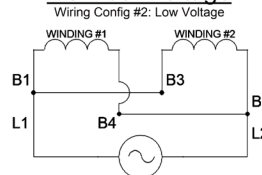

Series 82,300 Continued

Division I Hazardous Location

1-082-3XX-00 Series Motor Mounted Brake

IP Rating: 40, 56

Enclosure Type: UL Type 1, UL Type 4, NEMA 7, NEMA 9

Mounting: 1-082-3XX-00 Series hazardous location motor mounted brake is used for mounting close coupled (directly) to the motor end bell. If brake is to be mounted to a motor fanguard, or if a motor frame adapter is incorporated, please contact the factory for information on Series 1-082-3X4-02, as it provides additional bearing support for the longer shaft that is required. The acceptability of the brake and motor combination must be determined by Underwriters Laboratories Inc.

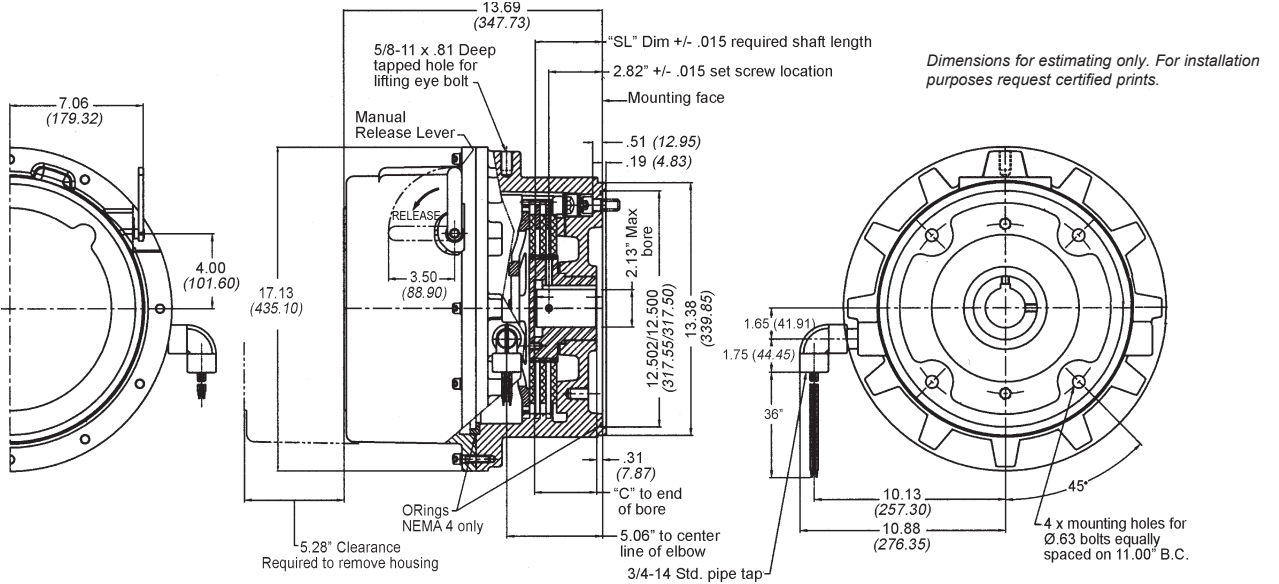

Model Number	Torque	C	SL
1-082-31X-00	125 lb-ft	2.79	3.03
1-082-32X-00	175 lb-ft	(70.87)	(76.96)
1-082-33X-00	230 lb-ft	3.29	3.53
1-082-34X-00	330 lb-ft	(83.57)	(89.66)

Above drawing is for motor mounted brake only. For fanguard mounted brake (1-082-3X4-02 series), request Stearns drawing no. 1-082-304-2D.

1-082-3X6-00 Series Foot Mounted Brake

IP Rating: 56

Enclosure Type: UL Type 4, NEMA 7, NEMA 9

Mounting: 1-082-3X6-00 Series hazardous location foot mounted brake does not require assembly to the motor to complete the hazardous location enclosure.



Hazardous-location brakes are intended essentially for non-cyclic or holding purposes, but may be used for stopping light inertial loads.

Dimensions for estimating only. For installation purposes, request certified prints.

*Keyseats made to ANSI B17.1 standard

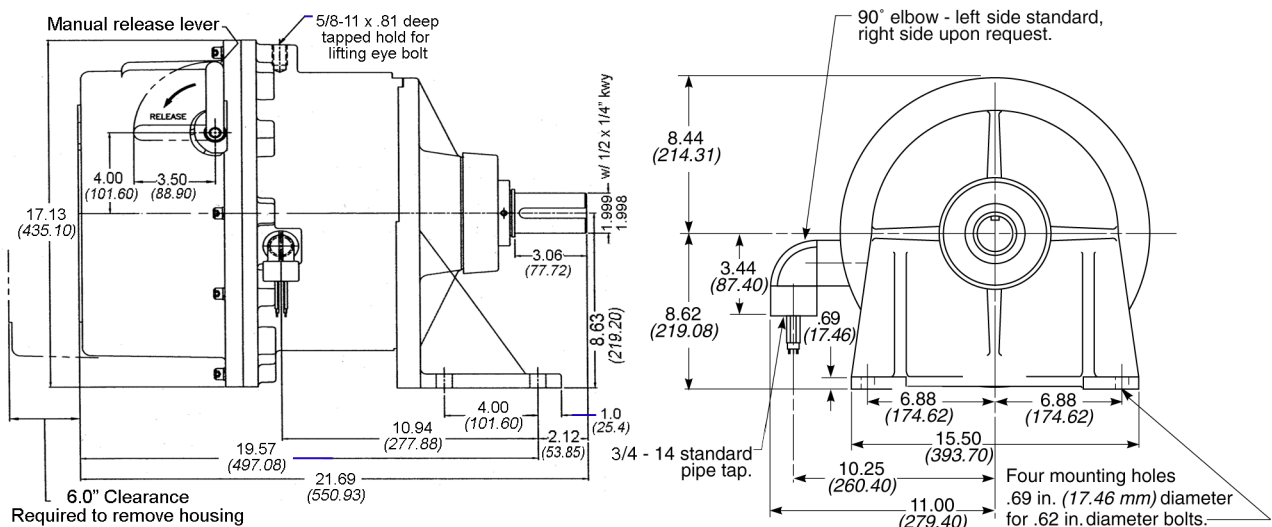

Series 56,800 (1-056-8XX)

Division 2 Hazardous Location

Mounting Face: NEMA 56C, 143TC & 145TC

4.5" AK, 5.88" AJ

Static Torque: 3 through 25 lb-ft

IP Rating: 56

Enclosure Material: Cast iron

Enclosure Type: UL Type 4

Release Type: Side lever, maintained with auto reset

Mounting: 1-056-8X2 Series hazardous location motor mounted brake is recommended for mounting close coupled to the motor end bell. The acceptability of the brake and motor combination must be determined by Underwriters Laboratory.

Universal Mounting: Through 15 lb-ft. 10, 15, 20 and 25 lb-ft. supplied with springs for vertical modification.

Modifications: See SAB modifications section.

Installation, Service & Parts List:
P/N 8-078-905-18



Features

- Coil insulation: Class 180(H)
- NC thermostat
- Maximum speed: horizontal 5000 rpm, vertical 3600 rpm
- UL Listed File E 14893 for Class 1 Division 2 Groups A, B, C and D; Class II Division 2 Groups F and G certified
- ABS type approval certified

Brake set and release times in milliseconds, when brake and motor are switched separately (for T1/T2 definitions, see set and release times section):

Static Torque	Coil Size	T1	T2
3 - 25	4	25	14

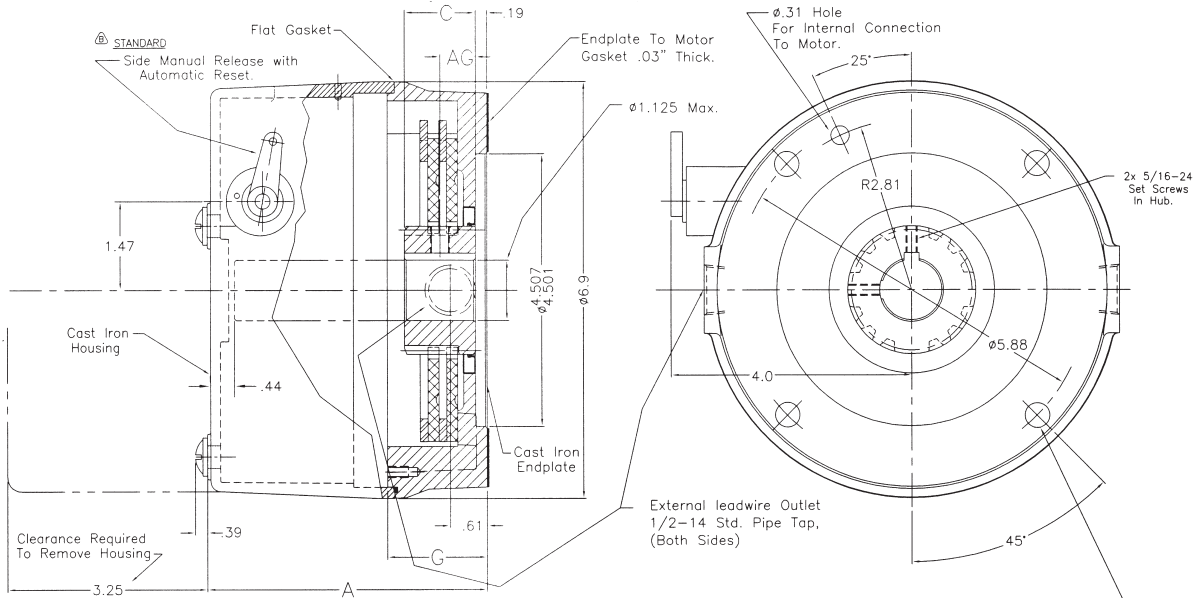

Dimensions for estimating only. For installation purposes request certified prints.

External leadwire Outlet 1/2-14 Std. Pipe Tap. (Both Sides)

Four Mounting Holes ϕ .395/.425, 180° Apart, For ϕ .38 Socket Head Screws, Two Screw Mounting 180° Apart Through 15 Lb-Ft. Four Screw Mounting Recommended For 20 & 25 Lb-Ft.

Motor Frame Adapters

WARNING! Before selecting an adapter to mount a brake on a larger motor frame, the torque and thermal capacity required by the application should be determined as shown in the selection procedure section. A larger motor may indicate a requirement for greater thermal capacity than the brake is designed for. The brake selection must be matched to the motor and application requirements, before use of an adapter is considered.

To Adapt to NEMA Frame Size	AK Dim. in. (mm)	Reg. No.	Brake Torque	Adapter Stock Number	Additional Shaft Length Required in. (mm)
182TC	8.50 (215.90)	-9	1.5-6	5-55-5041-00	.94 (23.81)
184TC					
213TC					
215TC	8.50 (215.90)	-9	10-25	5-55-5043-00	.94 (23.81)
254TC					
256TC					

For adapter dimensions, see technical data.

Dimensions

Model Number	Nominal Static Torque lb-ft (Nm)	Dimensions in Inches (Dimensions in Millimeters)				IP Rating	Enclosure	Wt. lbs (kg)
		A	AG	C	G			
1-056-812-00	3 (4)	4.7 (119.4)	.59 (15.0)	1.18 (30.0)	1.66 (42.2)	IP 56	UL Type 4	15 (6.8)
1-056-822-00	6 (8)	4.7 (119.4)	.59 (15.0)	1.18 (30.0)	1.66 (42.2)	IP 56	UL Type 4	15 (6.8)
1-056-832-00	10 (14)	4.7 (119.4)	.59 (15.0)	1.18 (30.0)	1.66 (42.2)	IP 56	UL Type 4	17 (7.7)
1-056-842-00	15 (20)	4.7 (119.4)	.59 (15.0)	1.18 (30.0)	1.66 (42.2)	IP 56	UL Type 4	17 (7.7)
1-056-852-00	20 (27)	4.7 (119.4)	.59 (15.0)	1.18 (30.0)	1.66 (42.2)	IP 56	UL Type 4	21 (9.5)
1-056-862-00	25 (34)	4.7 (119.4)	.59 (15.0)	1.18 (30.0)	1.66 (42.2)	IP 56	UL Type 4	21 (9.5)

Series 56,800 Continued

Division 2 Hazardous Location

Engineering Specifications

Nominal Static Torque lb-ft (Nm)	No. of Friction Discs	Coil Size	Maximum Solenoid Cycle Rate ^① cycle/min	Thermal Capacity ^②	Inertia (Wk ²) lb-ft ² (kgm ² x 10 ⁻⁴)
				hp-sec/min (watts) Horizontal	
3 (4)	2	4	7.5	3.5 (43.50)	.014 (5.88)
6 (8)	2	4	7.5	3.5 (43.50)	.014 (5.88)
10 (14)	2	4	7.5	3.5 (43.50)	.014 (5.88)
15 (20)	2	4	7.5	3.5 (43.50)	.014 (5.88)
20 (27)	3	4	7.5	3.5 (43.50)	.020 (8.40)
25 (34)	3	4	7.5	3.5 (43.50)	.020 (8.40)

Current Ratings (amperes)

Coil Size	Current	Voltage: 60 Hz						Voltage: 50 Hz		
		115 Vac	200 Vac	230 Vac	400 Vac	460 Vac	575 Vac	110 Vac	220 Vac	380 Vac
4	Inrush	3.6	2.1	1.8	1.1	.9	.7	4.1	2.1	.9
	Holding	.3	.2	.2	.08	.08	.06	.3	.2	.08
4	Inrush	4.3	2.5	2.2	1.3	1.1	.9	3.8	1.9	1.1
	Holding	.3	.2	.2	.1	.08	.07	.4	.2	.08
4	Inrush	4.6	2.5	2.3	1.2	1.0	.9	4.9	2.0	1.0
	Holding	.4	.2	.2	.1	.1	.08	.4	.2	.1
4	Inrush	4.6	2.5	2.3	1.2	1.0	.9	4.1	2.0	1.3
	Holding	.4	.2	.2	.1	.1	.08	.4	.2	.1

- ① Maximum solenoid cycle rate is based on ambient temperature of 104°F (40°C) with 50% duty cycle. Does relate to brake cycle rate (see thermal capacity).
- ② Thermal capacity rating is based on ambient temperature of 104°F (40°C), stop time of one second or less, with no heat absorbed from motor. Derate thermal capacity by 25% for vertical mounting. Refer to selection procedure section.

Ordering & Identification Information

The following example and tables provide information for selecting the appropriate three-letter suffix when ordering a Stearns brake.

Example of a complete part number: 1-056-832-00-BFF — Lead wire position (internal and external, left and right)

└─ 230 Vac

└─ 5/8 bore and 3/16 x 3/32 keyway

SAB Voltage Chart

Voltage Character in Brake P/N	Coil Type ⁴	Nominal Voltage ^{1,2} [VAC]			
		Wiring Configuration #1		Wiring Configuration #2	
		@60Hz	@50Hz	@60Hz	@50Hz
B	1	115	95	N/A	
D		132	110		
E		200	165		
F		230	190		
H		264	220		
L		460	380		
M		498	415		
N		575	480		
O	2	264	220	132	110
P		230 ³	190	115	95
Q		460	380	230 ³	190
R		400	330	200	165

Hub Selection

Character	Bore (in.)	Keyway** (in. x in.)
A*	5/8	1/8 x 1/16
B	5/8	3/16 x 3/32
C	3/4	3/16 x 3/32
D	7/8	3/16 x 3/32
E	1-1/8	1/4 x 1/8
F*	1-1/4	1/4 x 1/8
K	1/2	1/8 x 1/16
L*	1	1/4 x 1/8
N*	9/16	1/8 x 1/16
O*	11/16	3/16 x 3/32
P*	1-1/6	1/4 x 1/8
R*	13/16	3/16 x 3/32
S*	15/16	1/4 x 1/8

Maximum allowable bore 1.25.
For thru-shaft applications, .875 is maximum.

*These bores are non-standard.

**Keyseats made to ANSI B17.1 standard.

- Bold text is the more common voltage & frequency combination.
- Operating Voltage Range is ± 10%
- If it's a Size 4 coil, the coil voltage is 208-230 (with a minimum operating voltage of 200VAC).
- 1=AC single voltage; 2=AC dual voltage.

AC Single Voltage

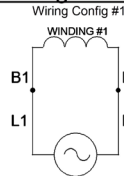

AC Dual Voltage

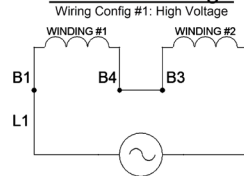

AC Dual Voltage

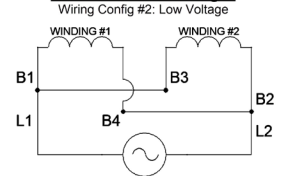

Series 87,800 (1-087-8XX)

Division 2 Hazardous Location

Mounting Face: NEMA 182TC, 184TC, 213TC, 215TC, 254TC, 254UC, 256TC & 256UC

8.5" AK, 7.25" AJ

Static Torque: 6 through 105 lb-ft

IP Rating: 56

Enclosure Material: Cast iron

Enclosure Type: UL Type 4

Release Type: Knob

Mounting: 1-87-8XX Series hazardous location motor mounted brake is recommended for mounting close coupled to the motor end bell. The acceptability of the brake and motor combination must be determined by Underwriters Laboratory.

Modifications: Modification required for vertical above mounting. For vertical below, modification required on 50-105 lb-ft. See SAB modification section.

Installation, Service & Parts List:

P/N 8-078-927-08



Features

- Coil insulation: Class 180(H)
- NC thermostat
- Maximum speed: horizontal 4000 rpm, vertical 3000 rpm
- UL Listed File E-14893 certified. For hazardous location classification, see dimensional data below.
- ABS type approval certified

Brake set and release times, when brake and motor are switched separately (for T1/T2 definitions, see set and release times section):

Static Torque	Coil Size	T1	T2
10, 15, 25, 50	5 & 6	42	20
35, 75, 105	8	48	20

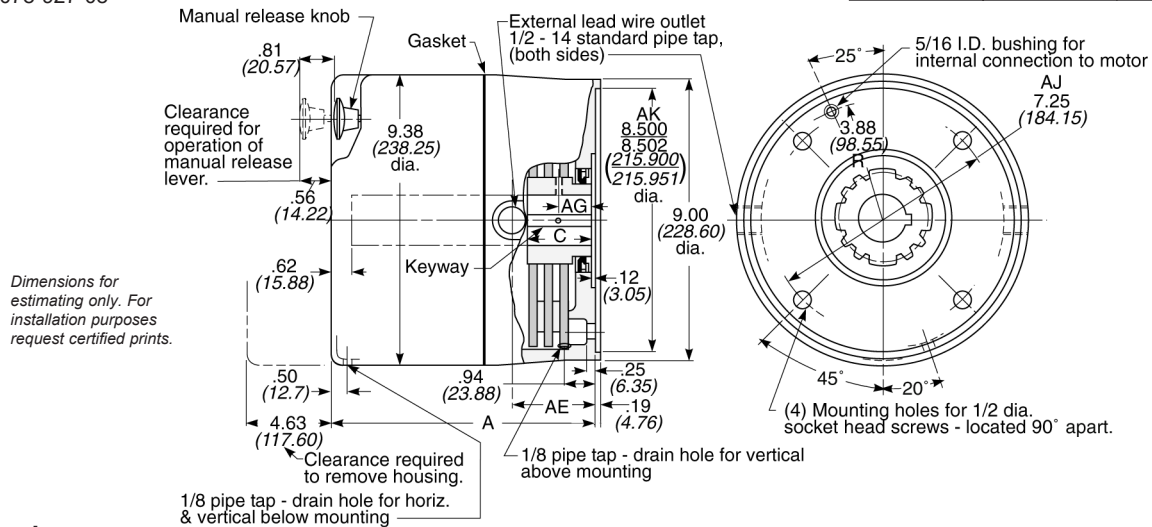

Dimensions

Model Numbers	Nominal Static Torque lb-ft (Nm)	Hazardous Location Classification Division 2		Dimensions in Inches (Dimensions in Millimeters)				IP Rating	Enclosure	Wt. lbs (kg)
		Class I Group -	Class II Group -	A	AE	AG	C			
1-087-802-00	6 (8)		F, G	7.56 (192.02)	1.81 (45.97)	.68 (17.29)	1.00 (25.4)	IP 56	UL Type 4	42 (19.1)
1-087-802-01	6 (8)	A, B, C, D	F, G	7.56 (192.02)	1.81 (45.97)	.68 (17.29)	1.00 (25.4)	IP 56	UL Type 4	42 (19.1)
1-087-812-00	10 (14)		F, G	7.56 (192.02)	1.81 (45.97)	.68 (17.29)	1.00 (25.4)	IP 56	UL Type 4	42 (19.1)
1-087-812-01	10 (14)	A, B, C, D	F, G	7.56 (192.02)	1.81 (45.97)	.68 (17.29)	1.00 (25.4)	IP 56	UL Type 4	42 (19.1)
1-087-822-00	15 (20)		F, G	7.56 (192.02)	1.81 (45.97)	.68 (17.29)	1.00 (25.4)	IP 56	UL Type 4	43 (19.5)
1-087-822-01	15 (20)	A, B, C, D	F, G	7.56 (192.02)	1.81 (45.97)	.68 (17.29)	1.00 (25.4)	IP 56	UL Type 4	43 (19.5)
1-087-832-00	25 (34)		F, G	7.56 (192.02)	1.81 (45.97)	.68 (17.29)	1.00 (25.4)	IP 56	UL Type 4	43 (19.5)
1-087-832-01	25 (34)	A, B, C, D	F, G	7.56 (192.02)	1.81 (45.97)	.68 (17.29)	1.00 (25.4)	IP 56	UL Type 4	43 (19.5)
1-087-842-00	35 (47)		F, G	7.56 (192.02)	1.81 (45.97)	.68 (17.29)	1.00 (25.4)	IP 56	UL Type 4	46 (20.9)
1-087-842-01	35 (47)	A, B, C, D	F, G	7.56 (192.02)	1.81 (45.97)	.68 (17.29)	1.00 (25.4)	IP 56	UL Type 4	46 (20.9)
1-087-852-00	50 (68)		F, G	8.06 (204.79)	2.31 (58.67)	.97 (24.64)	1.50 (38.10)	IP 56	UL Type 4	42 (19.1)
1-087-852-01	50 (68)	A, B, C, D	F, G	8.06 (204.79)	2.31 (58.67)	.97 (24.64)	1.50 (38.10)	IP 56	UL Type 4	42 (19.1)
1-087-862-00	75 (102)		F, G	8.06 (204.79)	2.31 (58.67)	.97 (24.64)	1.50 (38.10)	IP 56	UL Type 4	50 (22.7)
1-087-862-01	75 (102)	A, B, C, D	F, G	8.06 (204.79)	2.31 (58.67)	.97 (24.64)	1.50 (38.10)	IP 56	UL Type 4	50 (22.7)
1-087-882-00	105 (142)		F, G	8.56 (217.42)	2.81 (71.37)	.97 (24.64)	2.00 (50.80)	IP 56	UL Type 4	50 (22.7)
1-087-882-01	105 (142)	A, B, C, D	F, G	8.56 (217.42)	2.81 (71.37)	.97 (24.64)	2.00 (50.80)	IP 56	UL Type 4	50 (22.7)

Series 87,800 Continued

Division 2 Hazardous Location

Motor Frame Adapters:

WARNING! Before selecting an adapter to mount a brake on a larger motor frame, the torque and thermal capacity required by the application should be determined as shown in the selection procedure section. A larger motor may indicate a requirement for greater thermal capacity than the brake is designed for. The brake selection must be matched to the motor and application requirements, before use of an adapter is considered.

To Adapt to NEMA Frame Size	AK Dim. in. (mm)	Reg. No.	Adapter Stock Number	Additional Shaft Length Required in. (mm)
56C 143TC 145TC	4.50 (114.30)	-05	Brake endplate is modified for 4.50 in. AK. An adapter is not furnished.	— (—)
			5-55-7043-00	.56 (14.22)
284TC 286TC	10.50 (266.70)	-11	5-55-7055-00	.81 (20.64)
324TC 326TC 364TC 365TC 404TC 405TC	12.50 (317.50)	-13	5-55-7046-00	.88 (22.22)

For adapter dimensions, see technical data.

Current Ratings (amperes)

Coil Size	Current	Voltage: 60 Hz						Voltage: 50 Hz		
		115 Vac	200 Vac	230 Vac	400 Vac	460 Vac	575 Vac	110 Vac	220 Vac	380 Vac
5	inrush	7.5	4.3	3.7	2.2	1.9	1.5	5.4	4.0	1.9
	holding	.5	.3	.2	.1	.1	.09	.3	.25	.1
6	inrush	13.0	7.5	6.5	3.7	3.2	2.6	9.4	5.6	3.2
	holding	.6	.4	.3	.2	.2	.1	.5	.3	.2
8	inrush	17.6	10.3	8.8	5.0	4.2	3.5	15.4	7.7	4.2
	holding	1.2	.7	.6	.3	.3	.3	.1	.5	.3

Engineering Specifications

Nominal Static Torque lb-ft (Nm)	No. of Friction Discs	Coil Size	Maximum Solenoid Cycle Rate ^① cycles/min	Thermal Capacity ^② hp-sec/min (watts)	Inertia (Wk ²) lb-ft. ² (kgm ² x 10 ⁻⁴)
6 (8)	1	5	4	14 (174)	.048 (20.34)
10 (14)	1	5	4	14 (174)	.048 (20.34)
15 (20)	1	6	4	14 (174)	.048 (20.34)
25 (34)	1	6	4	14 (174)	.048 (20.34)
35 (47)	1	8	4	14 (174)	.048 (20.34)
50 (68)	2	6	4	14 (174)	.089 (37.40)
75 (102)	2	8	4	14 (174)	.089 (37.40)
105 (142)	3	8	4	14 (174)	.129 (54.45)

① Maximum solenoid cycle rate is based on ambient temperature of 104°F (40°C) with 50% duty cycle. Does relate to brake cycle rate (see thermal capacity).

② Thermal capacity rating is based on ambient temperature of 104°F (40°C), stop time of one second or less, with no heat absorbed from motor. Derate thermal capacity by 25% for vertical mounting. Refer to selection procedure section.

Optional space heater for Class II brakes only.

Ordering & Identification Information

The following example and tables provide information for selecting the appropriate three-letter suffix when ordering a Stearns brake.

Example of a complete part number:

1-087-832-01-ELF — Lead wire position (internal and external, left and right)
 460 Vac
 1-1/8 bore and 1/4 x 1/8 keyway

Hub Selection

Character	Bore (in.)	Keyway** (in. x in.)
A*	5/8	1/8 x 1/16
B*	5/8	3/16 x 3/32
C*	3/4	3/16 x 3/32
D	7/8	3/16 x 3/32
E	1-1/8	1/4 x 1/8
F	1-1/4	1/4 x 1/8
G	1-3/8	5/16 x 5/32
H	1-5/8	3/8 x 3/16
I*	1-3/4	3/8 x 3/16
K*	1/2	1/8 x 1/16
L*	1	1/4 x 1/8
M*	1-1/2	3/8 x 3/16
O*	11/16	3/16 x 3/32
P*	1-1/16	1/4 x 1/8
Q*	1-7/16	3/8 x 3/16
R*	13/16	3/16 x 3/32
S*	15/16	1/4 x 1/8
T*	1-3/16	1/4 x 1/8
U*	1-5/16	5/16 x 5/32
Z	.600	1/4 x 1/8 pilot bore

Maximum allowable bore 1.625.

*These bores are non-standard.

**Keyseats made to ANSI B17.1 standard.

SAB Voltage Chart

Voltage Character in Brake P/N	Coil Type ⁴	Nominal Voltage ^{1,2} [VAC]						
		Wiring Configuration #1		Wiring Configuration #2				
		@60Hz	@50Hz	@60Hz	@50Hz			
B	1	115	95	N/A				
D		132	110					
E		200	165					
F		230	190					
H		264	220					
L		460	380					
M		498	415					
N		575	480					
O		2	264			220	132	110
P			230 ³			190	115	95
Q	460		380	230 ³	190			
R	400		330	200	165			

1. Bold text is the more common voltage & frequency combination.

2. Operating Voltage Range is ± 10%

3. If it's a Size 4 coil, the coil voltage is 208-230 (with a minimum operating voltage of 200VAC).

4. 1=AC single voltage; 2=AC dual voltage.

AC Single Voltage

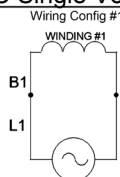

AC Dual Voltage

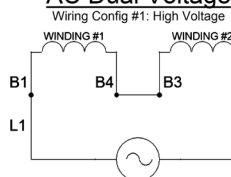

AC Dual Voltage

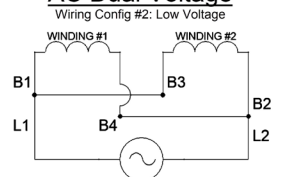

Series 56,700 (1-056-7XX) Die Cast Aluminum & (1-056-7XS) Stainless Steel

Mounting Face: NEMA 56C, 143TC & 145TC

4.5" AK, 5.88" AJ

Static Torque: 1.5 through 25 lb-ft

IP Rating: 23, 54/56*, 56

Enclosure Material: Die cast aluminum, stainless steel

Enclosure Type: UL Type 1, UL Type 4X

Release Type: Knob, maintained with automatic reset

Universal Mounting: Through 15 lb-ft.
20 and 25 lb-ft. supplied with springs for vertical modification. 56,700 Series mounts between C-Face motor and reducer. Do not apply overhung load to brake output shaft.

Modifications: See SAB modifications section.

Installation & Service Instructions:

P/N 8-078-905-67

Parts List: P/N 8-078-906-07

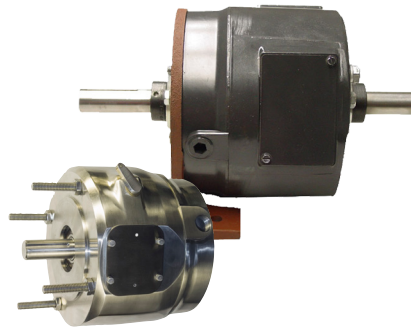

Features

- Spring-set electrically released
- ABS type approval certified
- Adjustable torque
- Manual release knob, maintained with automatic reset
- Manual wear adjustment
- Maximum speed: 5000 rpm horizontal, 3600 rpm vertical

Brake set and release times in milliseconds, when brake and motor are switched separately (for T1/T2 definitions, see set and release times section):

Static Torque lb-ft	Coil Size	T1	T2
1½ - 25	4	25	14

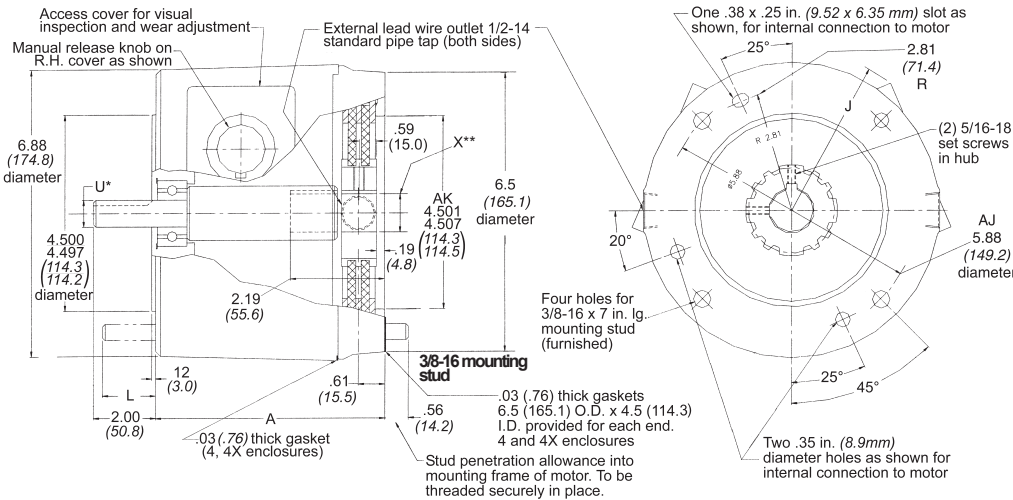

**For X and U dimensions, see *Ordering and Identification Information*.

Dimensions for estimating only. For installation purposes request certified prints.

Dimensions

Nominal Static Torque lb-ft (Nm)	IP Rating	Enclosure	Basic Model Number**	Dimensions in Inches (mm)			Wt. lbs (kg)
				A	J	L	
1.5 (2)	IP 23	UL Type 1	1-056-701-0X	4.91 (124.7)	3.81 (96.8)	1.53 (38.9)	12 (5.4)
	IP 54/56*	UL Type 1	1-056-702-0X	4.94 (125.5)	3.88 (98.6)	1.53 (38.9)	13 (5.9)
	IP 56	UL Type 4X	1-056-704-0X	4.94 (125.5)	3.88 (98.6)	1.53 (38.9)	13 (5.9)
3 (4)	IP 23	UL Type 1	1-056-711-0X	4.91 (124.7)	3.81 (96.8)	1.53 (38.9)	12 (5.4)
	IP 54/56*	UL Type 1	1-056-712-0X	4.94 (125.5)	3.88 (98.6)	1.53 (38.9)	13 (5.9)
	IP 56	UL Type 4X	1-056-714-0X	4.94 (125.5)	3.88 (98.6)	1.53 (38.9)	13 (5.9)
	IP 56	UL Type 4X	1-056-71S-0X	4.94 (125.5)	3.88 (98.6)	1.53 (38.9)	22 (10)
6 (8)	IP 23	UL Type 1	1-056-721-0X	4.91 (124.7)	3.81 (96.8)	1.53 (38.9)	12 (5.4)
	IP 54/56*	UL Type 1	1-056-722-0X	4.94 (125.5)	3.88 (98.6)	1.53 (38.9)	13 (5.9)
	IP 56	UL Type 4X	1-056-724-0X	4.94 (125.5)	3.88 (98.6)	1.53 (38.9)	13 (5.9)
	IP 56	UL Type 4X	1-056-72S-0X	4.94 (125.5)	3.88 (98.6)	1.53 (38.9)	22 (10)
10 (14)	IP 23	UL Type 1	1-056-731-0X	4.91 (124.7)	3.81 (96.8)	1.53 (38.9)	12 (5.4)
	IP 54/56*	UL Type 1	1-056-732-0X	4.94 (125.5)	3.88 (98.6)	1.53 (38.9)	13 (5.9)
	IP 56	UL Type 4X	1-056-734-0X	4.94 (125.5)	3.88 (98.6)	1.53 (38.9)	13 (5.9)
	IP 56	UL Type 4X	1-056-73S-0X	4.94 (125.5)	3.88 (98.6)	1.53 (38.9)	22 (10)

Dimensions Continued

Nominal Static Torque lb-ft (Nm)	IP Rating	Enclosure	Basic Model Number**	Dimensions in Inches (mm)			Wt. lbs (kg)
				A	J	L	
15 (20)	IP 23	UL Type 1	1-056-741-0X	4.91 (124.7)	3.81 (96.8)	1.53 (38.9)	12 (5.4)
	IP 54/56*	UL Type 1	1-056-742-0X	4.94 (125.5)	3.88 (98.6)	1.08 (27.4)	13 (5.9)
	IP 56	UL Type 4X	1-056-744-0X	4.94 (125.5)	3.88 (98.6)	1.08 (27.4)	13 (5.9)
	IP 56	UL Type 4X	1-056-74S-0X	4.94 (125.5)	3.88 (98.6)	1.53 (38.9)	22 (10)
20 (27)	IP 23	UL Type 1	1-056-751-07	5.36 (136.1)	3.81 (96.8)	1.08 (27.4)	12 (5.4)
	IP 54/56*	UL Type 1	1-056-752-07	5.39 (136.9)	3.88 (98.6)	1.08 (27.4)	14 (6.3)
	IP 56	UL Type 4X	1-056-754-07	5.39 (136.9)	3.88 (98.6)	1.08 (27.4)	14 (6.3)
	IP 56	UL Type 4X	1-056-75S-0X	5.39 (136.9)	3.88 (98.6)	1.08 (27.4)	22 (10)
25 (34)	IP 23	UL Type 1	1-056-761-07	5.36 (136.1)	3.81 (96.8)	1.08 (27.4)	13 (5.9)
	IP 54/56*	UL Type 1	1-056-762-07	5.39 (136.9)	3.88 (98.6)	1.08 (27.4)	14 (6.3)
	IP 56	UL Type 4X	1-056-764-07	5.39 (136.9)	3.88 (98.6)	1.08 (27.4)	14 (6.3)
	IP 56	UL Type 4X	1-056-76S-0X	5.39 (136.9)	3.88 (98.6)	1.08 (27.4)	22 (10)

*IP 54; IP 56 with motor gasket.

**X in 9th digit designates hub bore and shaft size.

Series 56,700 Continued

Engineering Specifications

Nominal Static Torque lb-ft (Nm)	No. of Friction Discs	Coil Size	Maximum Solenoid Cycle Rate ^① cycles/min	Thermal Capacity ^② hp-sec/min (watts)		Inertia (Wk ²) lb - ft ² (kgm ² x 10 ⁻⁴)
				Horizontal	Vertical	
1.5 (2)	1	4	36	9 (112)	6.5 (80)	.008 (3.36)
3 (4)	1	4	36	9 (112)	6.5 (80)	.008 (3.36)
6 (8)	1	4	36	9 (112)	6.5 (80)	.008 (3.36)
10 (14)	2	4	36	9 (112)	6.5 (80)	.014 (5.88)
15 (20)	2	4	36	9 (112)	6.5 (80)	.014 (5.88)
20 (27)	3	4	36	9 (112)	6.5 (80)	.020 (8.40)
25 (34)	3	4	36	9 (112)	6.5 (80)	.020 (8.40)

① Maximum solenoid cycle rate is based on ambient temperature of 72°F (22°C) with 50% duty cycle. Does not relate to brake cycle rate (see thermal capacity).

② Thermal capacity rating is based on ambient temperature of 72°F (22°C), stop time of one second or less, with no heat absorbed from motor. Refer to selection procedure section.

Current Ratings (amperes)

Coil Size	Current	Voltage: 60 Hz						Voltage: 50 Hz		
		115 Vac	200 Vac	230 Vac	400 Vac	460 Vac	575 Vac	110 Vac	220 Vac	380 Vac
4	inrush holding	4.6 .4	2.5 .2	2.3 .2	1.2 .1	1.0 .1	.9 .08	4.1 .4	2.0 .2	1.3 .1

Ordering & Identification Information

The following example and tables provide information for selecting the appropriate three-letter suffix when ordering a Stearns brake.

Example of a complete part number:

1-056-731-05—FF — Lead wire position (internal and external, left and right)
 Series — 230 Vac
 Torque — Does not apply
 Enclosure — 5/8 hub bore and shaft

Hub Bore, Shaft & Keyway Sizes

9th Digit of Model No.	Bore Dia. (X)	Keyway**	Shaft Dia. (U)	Keyway**
5	.625	.19 x .09	.625	.19 x .09
7	.875	.19 x .09	.875	.19 x .09
8*	.875 with sleeve to convert to .625	.19 x .09	.625 with sleeve to convert to .875	.19 x .09

*One sleeve provided in each brake.

**Keyseats made to ANSI B17.1 standard.

SAB Voltage Chart

Voltage Character in Brake P/N	Coil Type ⁴	Nominal Voltage ^{1,2} [VAC]			
		Wiring Configuration #1		Wiring Configuration #2	
		@60Hz	@50Hz	@60Hz	@50Hz
B	1	115	95	N/A	
D		132	110		
E		200	165		
F		230	190		
H		264	220		
L		460	380		
M		498	415		
N		575	480		
O	2	264	220	132	110
P		230³	190	115	95
Q		460	380	230³	190
R		400	330	200	165

1. Bold text is the more common voltage & frequency combination.

2. Operating Voltage Range is ± 10%

3. If it's a Size 4 coil, the coil voltage is 208-230 (with a minimum operating voltage of 200VAC).

4. 1=AC single voltage; 2=AC dual voltage.

AC Single Voltage

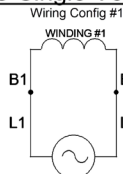

AC Dual Voltage

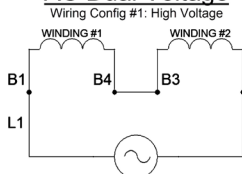

AC Dual Voltage

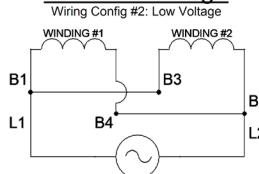

Series 87,700 (1-087-7XX)

Mounting Face: NEMA 182TC 184TC, 213TC, 215TC, 254TC, 254UC, 256TC & 256UC

Double C-Face Coupler

8.5" AK, 7.25" AJ

Static Torque: 10 through 105 lb-ft

IP Rating: 23, 54/56*, 56

Enclosure Material: Aluminum housing, cast iron endplate

Enclosure Type: UL Type 1, UL Type 4X

Release Type: Side lever, maintained with automatic reset

Modifications: Modification required for vertical above mounting. For vertical below, modification required on 50-105 lb-ft. See SAB modifications section.

Installation & Service Instructions:
P/N 8-078-927-27 Rev. B & C

Parts List: P/N 8-078-917-57 Rev. B
P/N 8-078-917-67 Rev. C



Features

- Spring-set electrically released
- ABS type approval certified
- Self-adjusting design
- Maximum speed: horizontal 4000 rpm
vertical 3600 rpm
- cURus File E71115 certified
- **Note: 87,700 Series mounts between C-face motor and reducer. Do not apply overhung load to brake output shaft.**

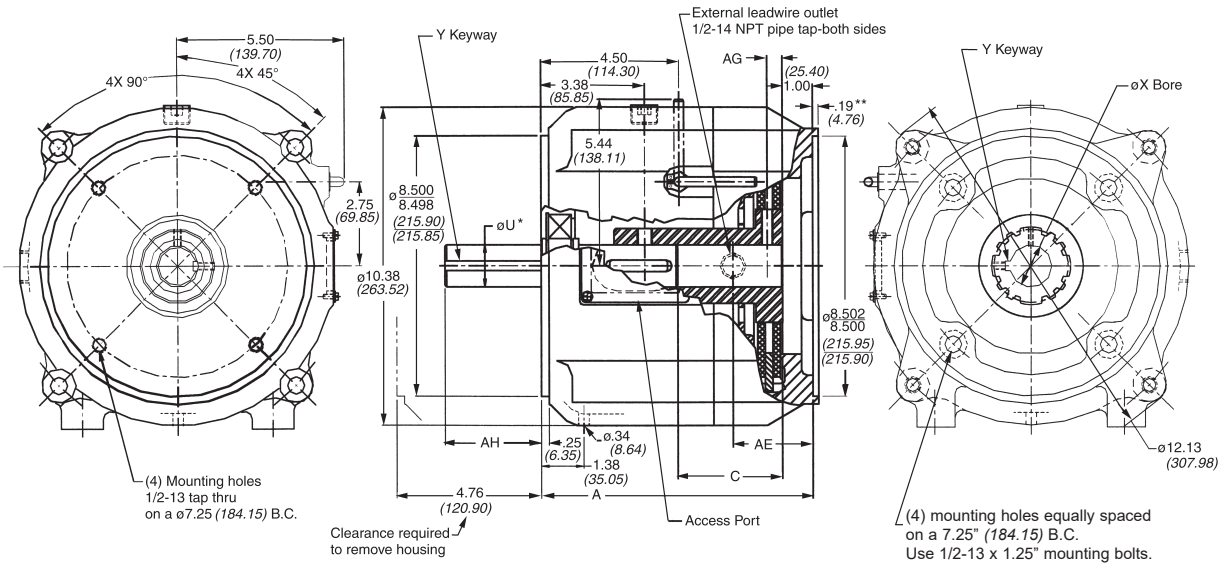

* For X and U dimensions, see ordering information and Identification Information. ** Hub location.
Dimensions for estimating only. For installation purposes request certified prints.

Dimensions

Nominal Static Torque lb-ft (Nm)	IP Rating	Enclosure	Basic Model Number**	Dimensions in Inches (Dimensions in Millimeters)				Wt. lbs (kg)
				A	AE	AG	C	
10 (14)	IP 23	UL Type 1	1-087-711-OX	8.38 (212.72)	2.12 (53.93)	.19 (4.83)	2.81 (71.44)	66 (30.0)
	IP 54/56*	UL Type 1	1-087-712-OX					
	IP 56	UL Type 4X	1-087-712-BX					
15 (20)	IP 23	UL Type 1	1-087-721-OX	8.38 (212.72)	2.12 (53.93)	.19 (4.83)	2.81 (71.44)	66 (30.0)
	IP 54/56*	UL Type 1	1-087-722-OX					
	IP 56	UL Type 4X	1-087-722-BX					
25 (34)	IP 23	UL Type 1	1-087-731-OX	8.38 (212.72)	2.12 (53.93)	.19 (4.83)	2.81 (71.44)	66 (30.0)
	IP 54/56*	UL Type 1	1-087-732-OX					
	IP 56	UL Type 4X	1-087-732-BX					
35 (47)	IP 23	UL Type 1	1-087-741-OX	8.38 (212.72)	2.12 (53.93)	.19 (4.83)	2.81 (71.44)	66 (30.0)
	IP 54/56*	UL Type 1	1-087-742-OX					
	IP 56	UL Type 4X	1-087-742-BX					
50 (68)	IP 23	UL Type 1	1-087-751-OX	8.88 (225.42)	2.62 (66.68)	.44 (11.18)	3.31 (84.14)	73 (33.0)
	IP 54/56*	UL Type 1	1-087-752-OX					
	IP 56	UL Type 4X	1-087-752-BX					
75 (102)	IP 23	UL Type 1	1-087-761-OX	8.88 (225.42)	2.62 (66.68)	.44 (11.18)	3.31 (84.14)	73 (33.0)
	IP 54/56*	UL Type 1	1-087-762-OX					
	IP 56	UL Type 4X	1-087-762-BX					
105 (142)	IP 23	UL Type 1	1-087-781-OX	9.38 (238.12)	3.12 (79.38)	1.00 (25.40)	3.81 (96.84)	80 (36.0)
	IP 54/56*	UL Type 1	1-087-782-OX					
	IP 56	UL Type 4X	1-087-782-BX					

*IP 54; IP 56 with motor gasket.

**X in 9th digit designates hub bore and shaft size.

Series 87,700 Specifications Continued

Specifications

Nominal Static Torque lb-ft (Nm)	No. of Friction Discs	Coil Size	Maximum solenoid Cycle Rate ^① cycles/min	Thermal Capacity ^② hp-sec/min (watts)	Inertia (Wk ²) lb-ft ² (kgm ² x 10 ⁻⁴)
10 (14)	1	5	30	17.5 (249)	.078 (32.76)
15 (20)	1	6	25	17.5 (249)	.078 (32.76)
25 (34)	1	6	25	17.5 (249)	.078 (32.76)
35 (47)	1	8	20	17.5 (249)	.078 (32.76)
50 (68)	2	6	25	17.5 (249)	.108 (45.36)
75 (102)	2	8	20	17.5 (249)	.108 (45.36)
105 (142)	3	8	20	17.5 (249)	.145 (60.90)

- ① Maximum solenoid cycle rate is based on ambient temperature of 72°F (22°C) with 50% duty cycle. Does not relate to brake cycle rate (see thermal capacity).
- ② Thermal capacity rating is based on ambient temperature of 72°F (22°C), stop time of one second or less, with no heat absorbed from motor. Derate thermal capacity by 25% for vertical mounting. Refer to selection procedure section.

Brake set and release times in milliseconds, when brake and motor are switched separately (for T1/T2 definitions, see set and release times section):

Static Torque	Coil Size	T1	T2
10, 15, 25, 50	5 & 6	42	20
35, 75, 105	8	48	20

Current Ratings (amperes)

Coil Size	Current	Voltage: 60 Hz					Voltage: 50 Hz			
		115 Vac	200 Vac	230 Vac	400 Vac	460 Vac	575 Vac	110 Vac	220 Vac	380 Vac
5	Inrush	7.5	4.3	3.7	2.2	1.9	1.5	5.4	4.0	1.9
	Holding	.5	.3	.2	.1	.1	.09	.3	.25	.1
6	Inrush	13.0	7.5	6.5	3.7	3.2	2.6	9.4	5.6	3.2
	Holding	.6	.4	.3	.2	.2	.1	.5	.28	.2
8	Inrush	17.6	10.3	8.8	5.0	4.2	3.5	15.4	7.7	4.2
	Holding	1.2	.7	.6	.3	.3	.24	.1	.5	.3

Ordering & Identification Information

The following example and tables provide information for selecting the appropriate three-letter suffix when ordering a Stearns brake.

Example of a complete part number:

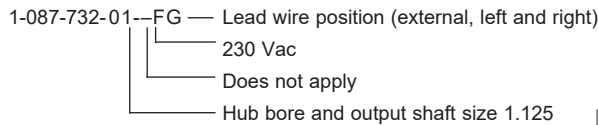

Hub Bore, Shaft & Keyway Sizes

9th Digit of Model Number	Dimensions in Inches (Dimensions in Millimeters)				
	Bore Dia. (X)	Keyway*	Shaft Dia. (U)	Keyway*	Shaft Length (AH)
1	1.125	.25 x .12	1.125	.25 x .12	2.62
	1.126		1.124		
3	($\frac{28.575}{28.600}$)	(6.35 x 3.18)	($\frac{28.575}{28.550}$)	(6.35 x 3.18)	(66.68)
	1.375	.31 x .16	1.375	.31 x .16	3.12
1.376	1.374				
5	($\frac{34.925}{34.950}$)	(7.94 x 3.97)	($\frac{34.905}{34.950}$)	(7.94 x 3.97)	(79.38)
	1.625	.38 x .19	1.625	.38 x .19	3.75
1.626	1.624				
5	($\frac{41.275}{41.300}$)	(9.52 x 4.76)	($\frac{41.275}{41.250}$)	(9.52 x 4.76)	(95.25)

For sizes other than those shown, contact factory.
No motor frame adapters or foot mounting kit available.

*Keyseats made to ANSI B17.1 standard.

SAB Voltage Chart

Voltage Character in Brake P/N	Coil Type ⁴	Nominal Voltage ^{1,2} [VAC]						
		Wiring Configuration #1		Wiring Configuration #2				
		@60Hz	@50Hz	@60Hz	@50Hz			
B	1	115	95	N/A				
D		132	110					
E		200	165					
F		230	190					
H		264	220					
L		460	380					
M		498	415					
N		575	480					
O		2	264			220	132	110
P			230 ³			190	115	95
Q	460		380	230 ³	190			
R	400		330	200	165			

1. Bold text is the more common voltage & frequency combination.
2. Operating Voltage Range is ± 10%
3. If it's a Size 4 coil, the coil voltage is 208-230 (with a minimum operating voltage of 200VAC).
4. 1=AC single voltage; 2=AC dual voltage.

AC Single Voltage

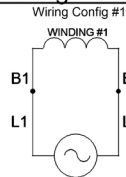

AC Dual Voltage

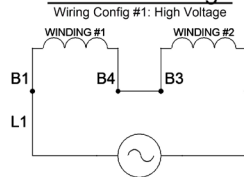

AC Dual Voltage

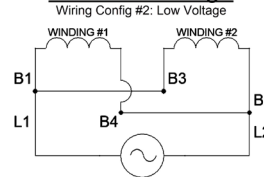

Series 56,703 (1-056-7X3)

Foot Mounted, Bearing-Supported Thru-Shaft

Static Torque: 1.5 through 25 lb-ft

IP Rating: 23

Enclosure Material: Die cast aluminum

Enclosure Type: UL Type 1

Release Type: Side release knob

Universal Mounting: 1.5 through 15 lb-ft.
20 and 25 lb-ft supplied with springs for vertical modification.

Modifications: See SAB modifications section. Maximum overhung or side load measured at one inch from end of shaft: 36 lbs.

Installation, Service & Parts List: P/N 8-078-905-27

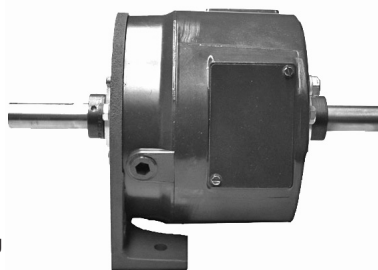

Brake set and release times in milliseconds, when brake and motor are switched separately (for T1/T2 definitions, see set and release times section):

Static Torque lb-ft	Coil Size	T1	T2
1½ - 25	4	25	24

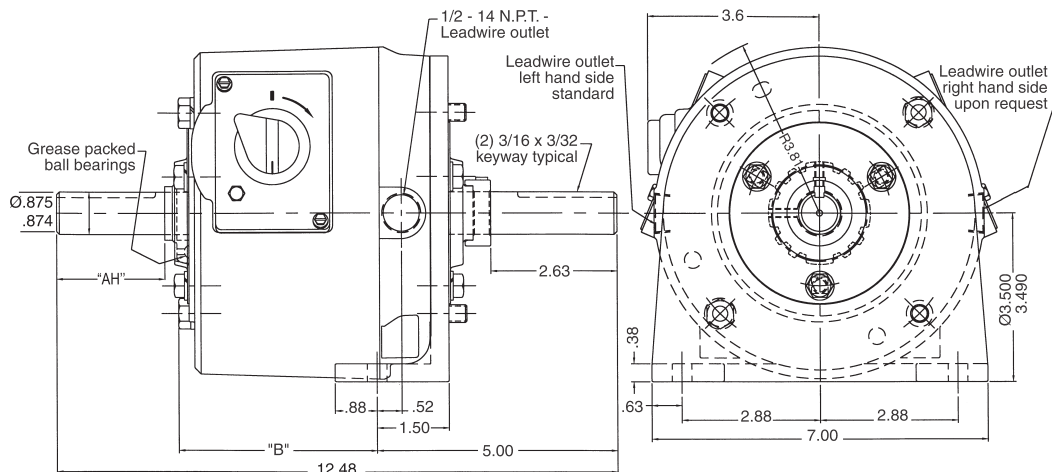

Dimensions

Nominal Static Torque		No. of Friction Discs	"B"	"AH"
Lb-ft	(Nm)			
1.5	(2)	1	4.13	2.69
3	(4)			
6	(8)			
10	(14)	2	4.56	2.25
15	(20)			
20	(27)	3	4.56	2.25
25	(34)			

Dimensions for estimating only. For installation purposes request certified prints.

Ordering & Identification Information

The following example and tables provide information for selecting the appropriate two-letter suffix when ordering this Stearns brake.

Example of a complete part number:

1-056-723-00-QC — Right hand leads
230/460 Vac
Shaft diameter is 7/8"

Example of a complete part number:

1-087-232-00-QC — Right hand leads
230/460 Vac
Shaft diameter is 1-1/4"

Nominal Static Torque		Basic Model Number
Lb-ft	(Nm)	
1.5	(2)	1-056-703-00-XX
3	(4)	1-056-713-00-XX
6	(8)	1-056-723-00-XX
10	(14)	1-056-733-00-XX
15	(20)	1-056-743-00-XX
20	(27)	1-056-753-00-XX
25	(34)	1-056-763-00-XX

Character	Lead Wire Position
B	Form 2
C	Form 3

Lead Wire Positions

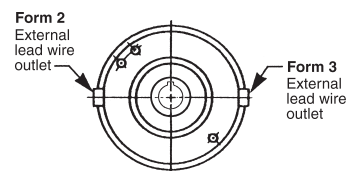

View facing mounting register on brake.

SAB Voltage Chart

Voltage Character in Brake P/N	Coil Type ⁴	Nominal Voltage ^{1,2} [VAC]			
		Wiring Configuration #1		Wiring Configuration #2	
		@60Hz	@50Hz	@60Hz	@50Hz
B	1	115	95	N/A	
D		132	110		
E		200	165		
F		230	190		
H		264	220		
L		460	380		
M		498	415		
N		575	480		
O	2	264	220	132	110
P		230³	190	115	95
Q		460	380	230³	190
R		400	330	200	165

AC Single Voltage

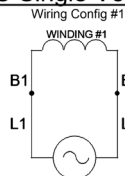

AC Dual Voltage

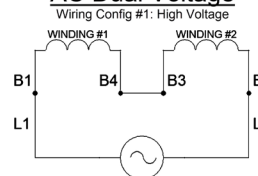

AC Dual Voltage

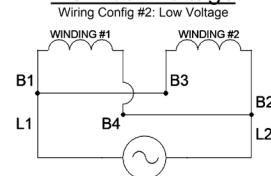

- Bold text is the more common voltage & frequency combination.
- Operating Voltage Range is $\pm 10\%$
- If it's a Size 4 coil, the coil voltage is 208-230 (with a minimum operating voltage of 200VAC).
- 1=AC single voltage; 2=AC dual voltage.

Series 87,200 (1-087-2XX)

Foot Mounted, Bearing-Supported Thru-Shaft

Static Torque: 10 through 105 lb-ft.

IP Rating: 23, 54/56*

Enclosure Material: Cast iron endplate and housing

Enclosure Type: UL Type 1

Release Type: Side lever, maintained with automatic release.

Modifications: See SAB modifications section for options.

Specifications: See 87,000 Series section.

Installation & Service Instructions:
P/N 8-078-927-00

Parts List: P/N 8-078-917-02



Maximum overhung, or side load measured at one inch from end of shaft: 100 lbs on brake housing side, 150 lbs on endplate/foot mount side

Brake set and release times in milliseconds, when brake and motor are switched separately (for T1/T2 definitions, see set and release times section):

Static Torque	Coil Size	T1	T2
10, 15, 25, 50	5 & 6	42	20
35, 75, 105	8	48	20

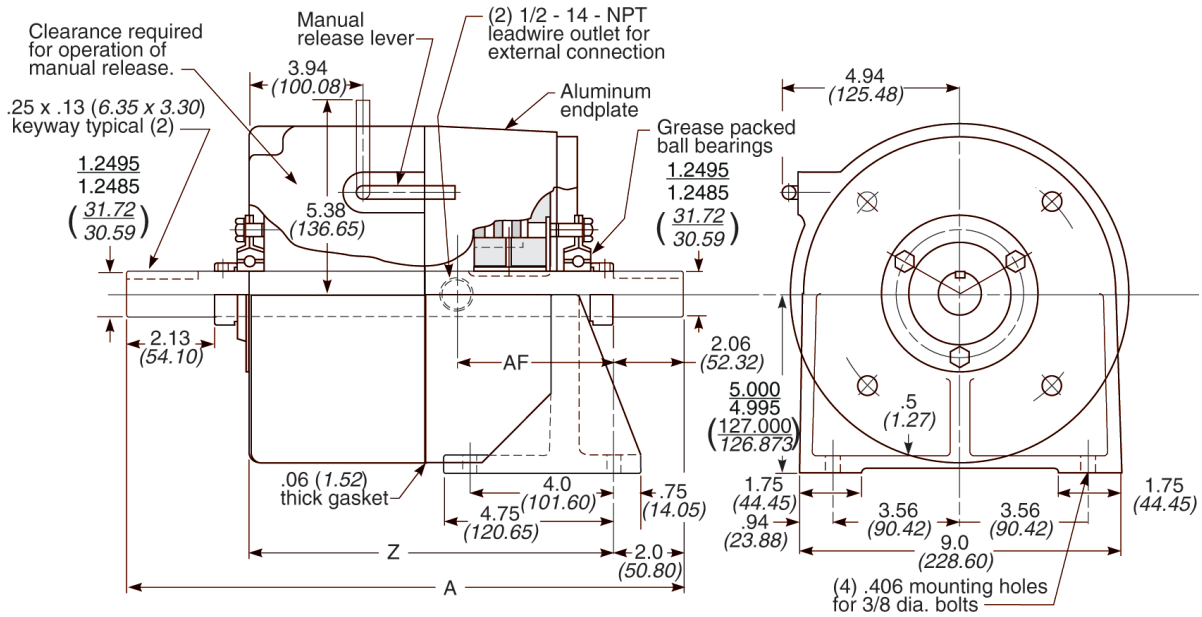

*Keyseats made to ANSI B17.1 standard.

Dimensions for estimating only. For installation purposes request certified prints.

Dimensions & Engineering Specifications

Nominal Static Torque lb-ft (Nm)	IP Rating	Enclosure	Basic Model Number**	Dimensions in Inches (Dimensions in Millimeters)			Thermal Capacity (hp-sec/min)	Inertia Wk ² (lb-ft ²)	Wt. lbs (kg)
				A	Z	AF			
10 (14)	IP 23	UL Type 1	1-087-211-00	14.56 (369.82)	9.32 (238.13)	3.56 (90.42)	17.5	.049	72 (33.0)
	IP 54/56*	UL Type 1	1-087-212-00	14.56 (369.82)	9.38 (238.25)	3.56 (90.42)			
15 (20)	IP 23	UL Type 1	1-087-221-00	14.56 (369.82)	9.32 (238.13)	3.56 (90.42)	17.5	.049	72 (33.0)
	IP 54/56*	UL Type 1	1-087-222-00	14.56 (369.82)	9.38 (238.25)	3.56 (90.42)			
25 (34)	IP 23	UL Type 1	1-087-231-00	14.56 (369.82)	9.32 (238.13)	3.56 (90.42)	17.5	.049	73 (33.0)
	IP 54/56*	UL Type 1	1-087-232-00	14.56 (369.82)	9.38 (238.25)	3.56 (90.42)			
35 (47)	IP 23	UL Type 1	1-087-241-00	14.56 (369.82)	9.32 (238.13)	3.56 (90.42)	17.5	.049	73 (33.0)
	IP 54/56*	UL Type 1	1-087-242-00	14.56 (369.82)	9.38 (238.25)	3.56 (90.42)			
50 (68)	IP 23	UL Type 1	1-087-251-00	15.06 (382.50)	9.81 (249.94)	4.06 (103.12)	17.5	.083	78 (35.0)
	IP 54/56*	UL Type 1	1-087-252-00	15.06 (382.50)	9.88 (250.95)	4.06 (103.12)			
75 (102)	IP 23	UL Type 1	1-087-261-00	15.06 (382.50)	9.81 (249.94)	4.06 (103.12)	17.5	.083	78 (35.0)
	IP 54/56*	UL Type 1	1-087-262-00	15.06 (382.50)	9.88 (250.95)	4.06 (103.12)			
105 (142)	IP 23	UL Type 1	1-087-281-00	15.56 (395.20)	10.32 (262.13)	4.56 (115.82)	17.5	.117	81 (37.0)
	IP 54/56*	UL Type 1	1-087-282-00	15.56 (395.20)	10.38 (263.65)	4.56 (115.82)			

*IP 54; IP 56 with motor gasket.

**See ordering information on previous page.

Marine, Maritime & Navy Brakes

Solenoid-Actuated Brakes

	Marine		Marine		Maritime		Navy
Description	Suitable for many shipboard and severe duty applications		Suitable for many shipboard and severe duty applications		Suitable for many Coast Guard, shipboard and severe duty applications when "ductile iron" is specified		Designed to Military Specification
Compliance (Note A)	IEEE 45 ABS		IEEE 45 ABS		IEEE 45 Federal Standard 46 ABS		MIL-DTL-16392D (Ships)
Spring Set Operation (Note E)	Armature Actuated Brake (AAB)		Solenoid Actuated Brake (SAB)				
Stearns Series (Note B)	350	360	1-056-200-K0	1-087-0xx-K0 1-082-0xx-K0 1-086-0xx-K0	1-087-Mxx	1-082-4xx 1-086-4xx	1-087-6xx 1-082-6xx 1-086-6xx
IP Rating	IP 56	IP 56	IP 54/56*	IP 56 (Note C)	IP 56		IP 56
Enclosure Finish	DI - Water Based Primer Alum - anodize MIL-A-8525 F		Water Based Primer		Alkyd Primer MIL TT-P-645C		Enamel MIL-E-15090
Coil	Class 180(H)		Class 180(H)		Class 180(H)		Class 180(H)
Endplate or Mount Plate Material	Steel		Cast Iron		Ductile Iron		Ductile Iron
Housing Material	Cast Aluminum or Ductile Iron		Cast Iron		Ductile Iron		Ductile Iron
Support Plate Material	N/A		Steel	(Note H)	Ductile Iron		Ductile Iron
Pressure Plate & Stationary Disc Material	N/A		Brass		Brass		Brass
Self Adjusting (Note G)	No, Gap By Gage		No, Gap By Scale	Yes	Yes		Yes
Manual Release (Note D)	Optional		Maintained		Maintained		Non-Maintained

- A. IEEE 45 compliance nameplate is optional. ABS certificate SB374021.
 B. Additional options and modifications are included in the full 12 digit part number.
 C. IP 56 with side release option available in 1-087-000-K0 and 1-082-000-K0.
 D. The maintained release holds the brake in a release condition until the brake is electrically, or manually, re-engaged. The non-maintained ("deadman") release is manually held in the released condition, re-setting when the force is removed.
 E. Spring-set, solenoid with coil and linkage actuated brake (SAB), AC voltage coil. Spring-set, armature actuated direct-acting brake (AAB), DC voltage coil.
 F. Carrier ring friction disc is standard with the 350 and 360 series and is an option in the SAB brakes.
 G. Stainless steel self-adjust is standard with the 1-08x-600 and 1-087-M00.
 H. 1-087: cast aluminum; 1-082: cast iron; 1-086: ductile iron.
 I. Dimensions may differ from catalog brakes; dimensional drawings available on request.
 *IP 54; IP 56 with motor gasket.

Armature-Actuated Brakes

MIL-B-16392C is inactive for new design and is no longer required, except for replacement purposes, per statement issued by Naval Sea Systems Command in June of 2001. The armature-actuated brake (AAB) was designed in consultation with Naval specification authorities as a suitable commercial off the shelf (COTS) motor brake.

Series 350 Pressure Plate Mount Internal Maintained Manual Release

Torque (lb-ft)	Model Number	NEMA Frame Size
75	3-51-734H0	182TC-256TSC
110	3-51-744H0	182TC-256TSC
110	3-51-744J0	284TC-286TSC
110	3-51-744K0	324TC-405TSC
180	3-51-844J0	284TC-286TSC
180	3-51-844K0	324TC-405TSC
300	3-51-944k0	324TC-405TSC

Series 360 Magnet Body Mount Internal Maintained & Optional External Non-Maintained Manual Release

Torque (lb-ft)	Model Number	NEMA Frame Size
60	3-61-644H0	182TC-256TSC
60	3-61-644J0	284TC-286TSC
75	3-61-734H0	182TC-256TSC
110	3-61-744H0	182TC-256TSC
110	3-61-744J0	284TC-286TSC
180	3-61-844J0	284TC-286TSC
180	3-61-844K0	324TC-405TSC
300	3-61-944K0	324TC-405TSC
300	3-61-944L0	444TC

Mining Brakes: MSHA Certified

Stearns 1-082-3X4-06 series of electric safety motor brakes are now certified for use in underground mines by the federal Mine Safety and Health Administration (MSHA).

Stearns is the only supplier of MSHA certified motor brakes.

MSHA approves and certifies products for use in underground coal and gassy mines to ensure that they do not cause a fire or explosion.



Static Torque: 125 through 330 lb-ft

IP Rating: 56

Enclosure Material: Cast iron

Enclosure Type: UL Type 4

Manual Release Type: Side lever, latching with automatic reset when electric power is applied to the brake coil.

Mounting Face: 12.5" AK, 11.0" AJ (NEMA 324 and 326 TC, NEMA 364 and 365 TC, NEMA 404 and 405 TC).

Modifications: See SAB modifications section.

Features

- Spring-set electrically released
- Self-adjust design: automatic adjustment for friction disc wear to reduce maintenance
- Fanguard mounted
- Coil insulation: Class 180(H)
- Thermal cut-out switch
- Electrical connections terminate at terminal block
- MSHA certification number: 18-XPA070006-0

Options

- Internal encoder
- Internal electric heater
- Electrical release indicator switch
- Carrier ring friction discs

Model No. IP56	No. of Discs	Torque Lb-Ft	C	**L	SL
1-082-314-06	2	125	5.72	4.63	5.65
1-082-324-06	2	175	5.72	4.63	5.65
1-082-334-06	3	230	6.22	5.13	6.15
1-082-344-06	3	330	6.22	5.13	6.15

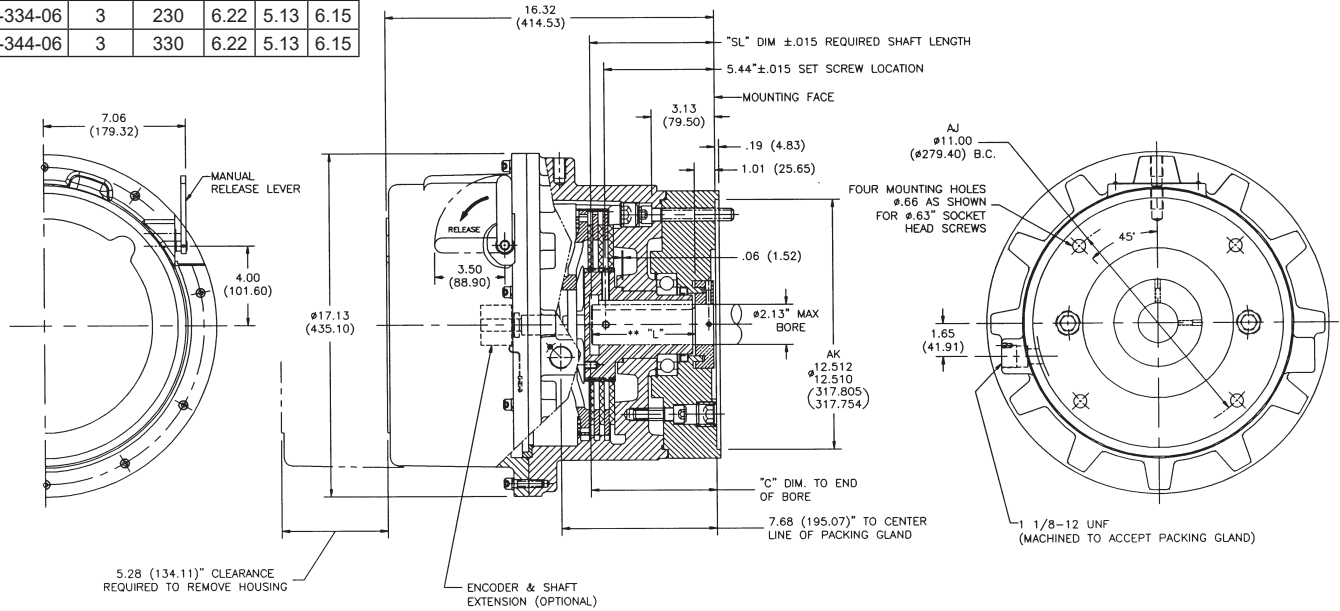

** "L" DIM. APPLIES TO MAXIMUM KEYWAY SLOT LENGTH.

Ordering Information - specify¹:

- Model Number
- Bore & keyway²
- Voltage²
- Options
- Leadwire packing gland - left or right (looking towards brake mounting face). Note: encoder option requires that the encoder wiring enters the brake from the opposite side of all of the other brake wiring.

Model No.	IP Rating	Enclosure	Nominal Static Torque lb-ft (Nm)
1-082-314-06	IP 56	UL Type 4	125 (169)
1-082-324-06	IP 56	UL Type 4	175 (237)
1-082-334-06	IP 56	UL Type 4	230 (312)
1-082-344-06	IP 56	UL Type 4	330 (447)

¹ These brakes need to be purchased from the motor manufacturer, as the required shaft length (dimension "SL" above) is not standard.

² Refer to 82,300 Series section.

Encoder Brakes

Stearns Solenoid Actuated Brakes with Internally Mounted Encoder

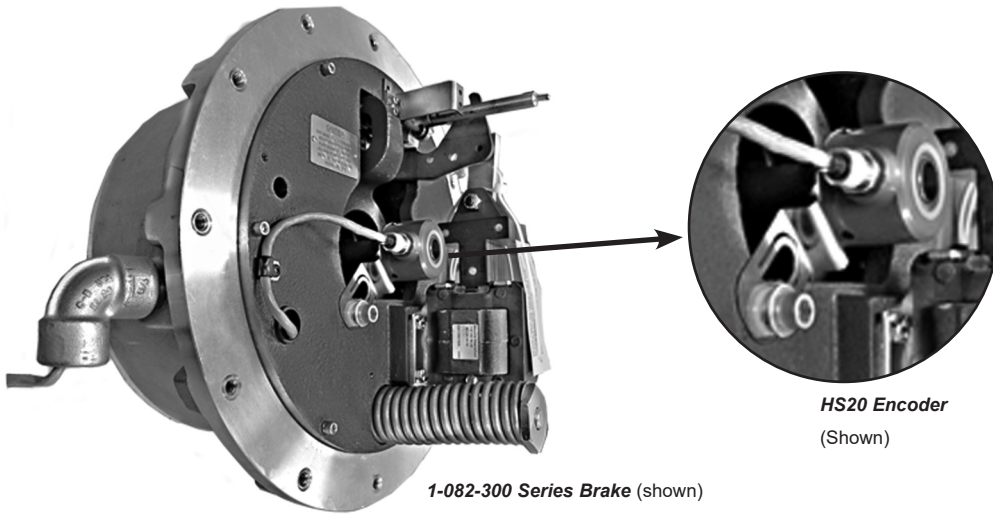

Features

- Available in frame sizes 182TC - 505TC
- All IP ratings available, including hazardous location
- Separate conduit exits are provided for the brake and encoder leads to minimize potential electrical interference
- Choice of popular encoder manufacturers

Benefits

- Encoder located in protected environment enclosed inside the brake housing
- Simplified encoder mounting
- Reduced package length - an internal encoder does not add any length to the brake
- Lower installed cost

Ordering Information

Stearns brakes with internal encoders are purchased through the motor manufacturer, as the required shaft length and diameter are non-standard. An internal encoder is not a retrofit option, like a brake coil, heater or switch. To order the brake motor package, specify the brake model and encoder option from table on following page.

Encoder Brakes Continued

Stearns Solenoid Actuated Brakes with Internally Mounted Encoder

Ordering Information

For Stearns solenoid actuated brakes (SABs) with internal encoders.

Industrial Locations

Frame Size	Brake Series	Torque Range lb-ft	Encoder Options ¹	Connector / Cable ²	Stearns Drawing No. ³
182TC - 256TC	1-087-EX2	25 - 105	Dynapar HS20 BEI HS20 BEI HS25	M12, 8 Pin / 15' M12, 8 Pin / 5m 10 Pin / 20'	1087E00ED 1087E00ED
324TC - 405TC	1-081-XXX	125 - 230	Dynapar HS20 BEI HS20 BEI HS25	M12, 8 Pin / 15' M12, 8 Pin / 5m 10 Pin / 20'	10810022ED 10810022ED
324TC - 405TC	1-082-XXX	125 - 440	Dynapar HS20 BEI HS20 BEI HS25	M12, 8 Pin / 15' M12, 8 Pin / 5m 10 Pin / 20'	10820022ED 10820022ED
444TC - 505TC	1-086-XXX	500 - 1000	Dynapar HS20 BEI HS20 BEI HS25 BEI HS35M	M12, 8 Pin / 15' M12, 8 Pin / 5m 10 Pin / 20' 10 Pin MS / 15'	10860022ED 10860022ED 10860022ED 10860022E35D

Division 1 Hazardous Location⁴

182TC - 256TC	1-087-3X8	10 - 105	Dynapar HS20 BEI HS20	M12, 8 Pin / 15' M12, 8 Pin / 5m	1087308D ⁵ 1087308D ⁵
324TC - 405TC	1-082-3X4	125 - 330	Dynapar HS20 BEI HS20	M12, 8 Pin / 15' M12, 8 Pin / 5m	1082304D ⁶ 1082304D ⁶

¹ Encoders are Optical, 1024 PPR. Options shown or factory approved equivalents may be used.

² Cables are shielded. Lengths are from encoder connector, inside the brake (not from outside of brake housing).

³ Request this drawing for shaft design requirements.

⁴ No motor shaft modifications required, beyond the brake requirements for a standard hazardous location brake.

⁵ Drawing 1087308D brake model mounts close-coupled to the motor end bell.

For the brake model that mounts to the motor fanguard, refer to drawing 10873081D.

For the brake model that mounts to the motor fanguard - with a slinger - refer to drawing 10873052D.

⁶ Drawing 1082304D brake model mounts close-coupled to the motor end bell.

For the brake model that mounts to the motor fanguard, refer to drawing 10823042D.

In addition to the fully enclosed brake with internal encoder options, encoders can be adapted externally to Stearns brakes:

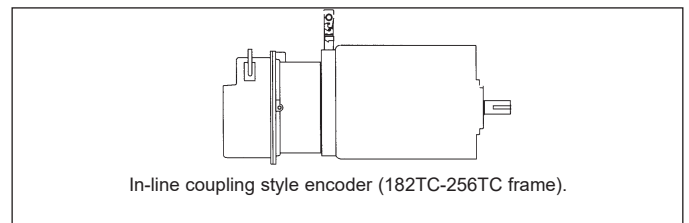
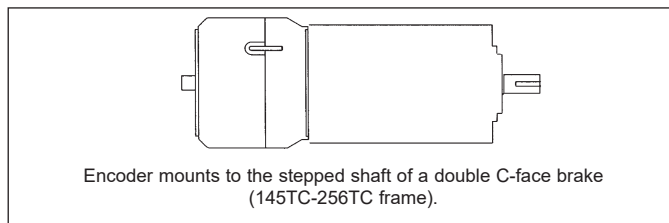
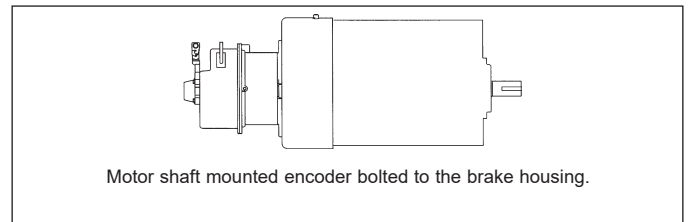
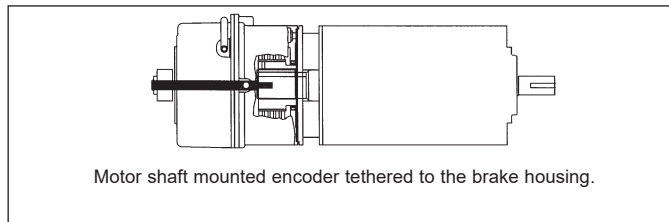

Information Needed for Modifications

Stearns is dedicated to providing you with the most comprehensive selection of modified spring-set disc brakes on the market today. We have included a list of our more popular modifications complete with descriptions, pictures and graphics when applicable along with their representative series.

Below please find examples of how the modifications are called out with a letter in the 8th position of the 12 digit model number. Note that these listings are not complete, but represent our more popular selections. For any special applications and modification requirements not found here, please contact your Stearns representative.

IMPORTANT – The modification letter will appear in the 8th position to call out the modification.

Examples:

1-056-XXX- X
└─── 8th position

1-087-XXX- X
└─── 8th position

1-08X-XXX- X
└─── 8th position

See specific tables for some of the available options of the series required.

If two or more letter modifications are required, the 8th position of the part number will remain zero and position 10, 11 and 12 will be assigned by Stearns as a special part number.

All Series

Modification	Letter
Vertical Mounting - Above Motor	A
Space Heater (115 Volt Circuit)	I
Space Heater (115 Volt Circuit), Brass Pressure Plate and Stationary Disc	J
Brass Pressure Plate and Stationary Disc	K
Vertical Mounting - Below Motor	L
Thru-Shaft Housing (Standard)	Q
Electrical Release Indicator Switch, N.O. contacts	W
Side Manual Release with Shaft Through Housing Stamped Steel	Z
Series 87,X00 Only	
Vertical Mounting - Above Motor, Brass Pressure Plate and Stationary Disc	N
Series 81,X00; 82,X00; 87,000 & 87,100	
Side Manual Release	Y

Solenoid Actuated Brakes Modification Index

Category	Description	Modification Number (M___)	Page
Corrosion Resistance	Brass Pressure Plate	M3	55
	Brass Stationary Disc	M4	55
	Breather Drain	M5	56
	Space Heater (115 or 230 volt)	M13	57
	Special Paint	M14	58
	Stainless Steel Self-Adjust	M15	58
	Stainless Steel Hardware	M16	58
	Corrosion-Resistant Endplate	M39	62
Stainless Steel Hub	M42	62	
Encoders	Encoders	M60	63
Endplates	Special Internal Leadwire Hole	M35	61
	Corrosion-Resistant Endplate	M39	62
	Special Milling: Flat Bottom on Housing & Endplate	M40	62
Friction Discs	Special Material Friction Disc	M44	63
	Carrier Ring Disc (Steel or Zinc Aluminum)	M46	63
	Carrier Ring Disc (Bronze)	M47	63
Gaskets	Viton® Gasket	M43	62
Hubs/ Brake Shaft	Non-Standard Bore or Keyway	M11	57
	Special Shaft - Coupler Brakes	M29	60
	Taper-Lock Hubs	M30	61
	Stainless Steel Hub	M42	62
	Splined Hub & Friction Disc	M45	63
Machining Options	Housing Machining for Encoder/Tach Mounting	M7	56
	Metric Machining	M33	61
	Special Milling: Flat Bottom on Housing & Endplate	M40	62
Manual Adjust	Manual Adjust for 87,000 Series	M48	63
Manual Release	Side Manual Release	M12	57
	Non-Maintained (Deadman)	M32	61
	Internal Release	M37	62
Mounting	Vertical	M21, M23, M24	59-60
	Metric Machining	M33	61
	Motor Frame Adapters	N/A	97
	Foot Mounting Kits	N/A	98
Nameplates	Mylar or Metal	M10	57
	Brass Nameplate	M41	62
Paint/ Special Finish or Material	Brass Pressure Plate	M3	55
	Brass Stationary Disc	M4	55
	Special Paint	M14	58
	Stainless Self-Adjust	M15	58
	Stainless Steel Hardware	M16	58
	Corrosion-Resistant Endplate	M39	62
	Stainless Steel Hub	M42	62
	Thru-Shaft	M19	59
Special Housing	Thru-Shaft with Lip Seal	M20	59
	Split Housing	M36	61
	Electrical Release Indicator	M1	55
Switches	Electrical Release Indicator Proximity Switch	M2	55
	Thermostat (Thermal) Switch	M18	58
	Wear Indicator	M27	60
	Tach Machining	M7	56
Tach Mounting	Thru-Shaft	M19	59
	Thru-Shaft with Lip Seal	M20	59
	Brass Pressure Plate	M3	55
Torque Derating	Brass Stationary Disc	M4	55
	Conduit Box with Terminal Strip	M8	56
Wiring Options	Terminal Strip	M17	58
	Internal Leadwire Hole	M35	61

M1 Electrical Release Indicator Switch

This switch is used to indicate when the brake is in a released, non-holding position. This mechanism utilizes a mechanical limit switch.

Applicable Series
56,X00*
81,000; 82,000; 87,X00*
86,X00

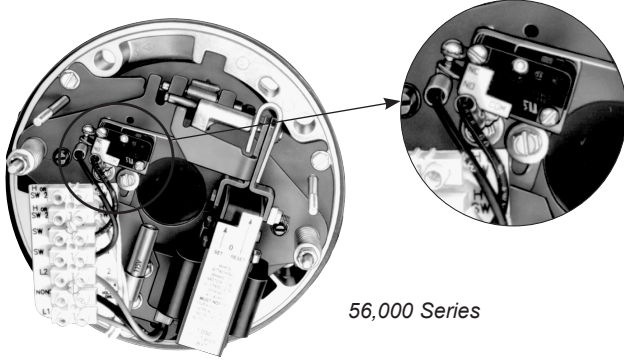

56,000 Series

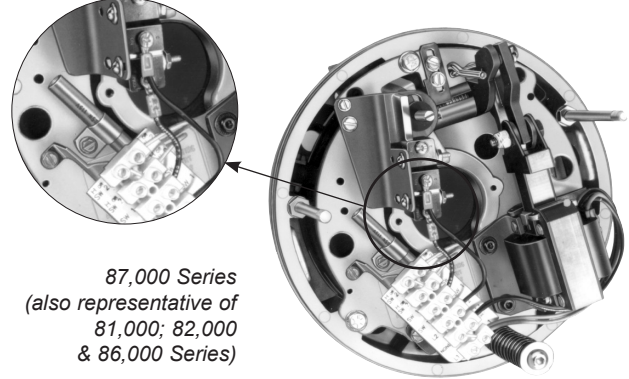

87,000 Series
(also representative of
81,000; 82,000
& 86,000 Series)

*Not available on 56,800, 65,300 or 87,800 Series brakes.

M2 Electrical Release Indicator Proximity Switch

Same function as the switch in M1 above; except, M2 uses an electronic proximity sensor.

Applicable Series
81,000
82,000
87,X00*
86,X00

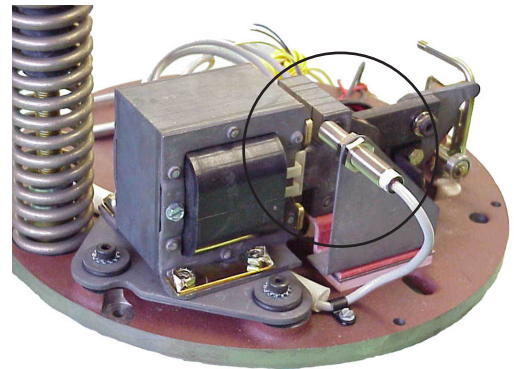

*Not available on 56,800 or 87,800 Series brakes.

M3 Brass Pressure Plate

Typically used in marine applications or in applications where the potential for sparks need to be eliminated. Brass can also be used to reduce torque.

Applicable Series
56,X00
65,X00
81,000; 82,000
86,X00
87,X00*



*Not available for 1-087-19X-00 125 lb-ft brake.

M4 Brass Stationary Discs

Used with brass pressure plate (list per disc).

Applicable Series
56,X00
65,X00
87,X00*
81,000; 82,000
86,X00

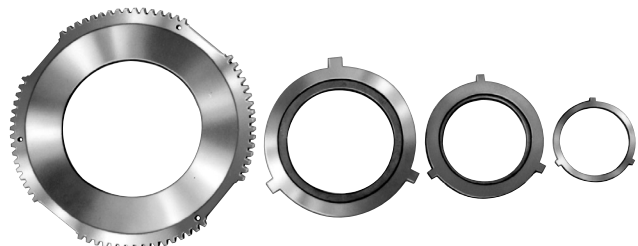

*Not available for 1-087-19X-00 125 lb-ft brake.

M5 Breather Drain

A drain plug is tapped into the bottom of the housing to let moisture escape. This option is only available on brakes with cast aluminum or cast iron housings.

Applicable Series
56,X00
65,X00
81,000 82,000 86,X00 87,X00



M7 Housing Machining for Encoder/Tach Mounting

Standard Machining*: The housing is machined for a thru shaft, and to allow for an encoder or tach to be mounted. This option is only available on brakes with cast aluminum or cast iron housings. Consult factory for availability.

Close Tolerance*: The housing and endplate are assembled and dowel pinned together - then machined as a matched set for a through shaft and encoder mounting. This option is only available on brakes with cast aluminum or cast iron housings. This option is recommended for Series 81,000; 82,000 and 86,X00 due to the long distance between the motor and encoder.

*Brakes that originally are IP 23 before tach machining; after tach machining, IP 23 with accessory and gasket provided by customer; IP 20 without. Brakes that originally are IP 56 with motor to endplate gasket installed; IP 54 without. After tach machining, brakes are IP 56 with accessory and gasket provided by customer and motor to endplate gasket installed; IP 20 without.

Tether Mount: The housing is machined for a through shaft, and a single tapped hole for a bolt to secure a tether arm. 56,X has a through hole and tach-welding nut on inside of housing, instead of a tapped hole.

Open Enclosure: Referred to on the product pages in the catalog as IP 23.

Enclosed: Referred to on the product pages as IP 56 (these ratings no longer apply when the housing is machined for this modification - the customer is responsible for meeting any specific enclosure rating when assembling the encoder).

**M7 Modification for Series 81,000 and 82,000 will also require the M12 Modification; the side manual release.

Applicable Series	Close Tolerance Bolt Circle & Register
	Maximum Thru-Shaft Dia. (inch)
56,X00 (except N/A for 56,800)	
87,000 - 87,100	1.63
87,M00 - 87,500 - 87,600	
81,000 - 82,000**	2.5
86,000	



M8 Conduit Box with Terminal Strip

A terminal strip is located inside the conduit box. It allows for easy connection and identification of lead wires.

Applicable Series
All series brakes except 48,100 series



M10 Nameplates

To order new brake nameplates, the serial number of the brake is required. A loose nameplate shipped from Stearns without being attached to a brake must have all agency markings removed (UL, etc.). In order to have a brake renameplated with the appropriate agency markings, it must be returned to Stearns for product verification.

M11 Nonstandard Hub or Keyway

For standard bore diameter and keyway specifications, see specific brake selection section.

For taper bores, consult factory.

M12 Side Manual Release

Side release not available on the 1-065-300 or the 1-086-000

Applicable Series Sheet Metal Housing (IP 23 Only)
56,000; 56,400; 56,500
87,000; 87,100

Applicable Series Cast Iron Housing
87,000 IP 23
87,000 IP 54/56*
81,000
82,000



*IP 54; IP 56 with motor gasket.

M13 Space Heater (115 or 230 Volt Only)

A space heater cartridge is used to prevent moisture build-up inside the brake housing.

Applicable Series	Wattage
56,X00*	15
81,000; 82,000 & 86,X00	50 & 75
87,X00**	25 to 30
Hazardous Duty Brakes	25 to 50

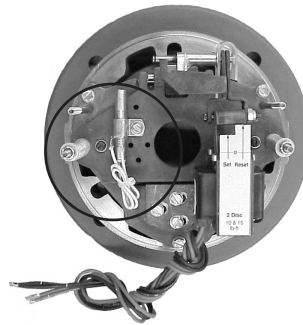

56,000 Series

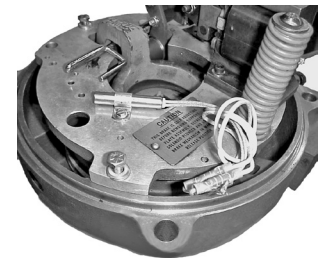

87,000 Series (also representative of 81,000; 82,000 & 86,000 Series)

*Not available on 1-056-800 Series brakes.

**Not available in 87,800 Class I.

M14 Special Paint

The standard paint for all brake series (except UL Type 4X and Maritime/Navy) is a red, water-base primer, painted inside and out.

For additional corrosion protection, a special (green) zinc chromate primer can be provided (painted inside and out) in place of the standard red primer. Consult factory for pricing.

Other Special Paint options are available - either primers, a white epoxy finish coat, or clean finish (exterior primer removed). Consult factory for pricing.

Maritime and Navy brakes have their own specified paints.

Applicable Series
56,X00
65,X00
81,000; 82,000 & 86,X00
87,000



M15 Stainless Steel Self-Adjust Mechanism

For severe duty applications. This option includes a stainless steel pinion and plated wrap spring in the auto-adjust mechanism. It is only available on the 81,000; 82,000; 86,000 and 87,000 Series brakes.

Applicable Series
81,000; 82,000 & 87,X00*
86,X00

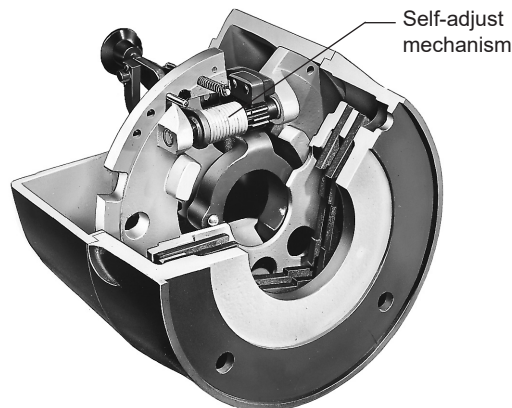

*Stainless steel self-adjust is standard on series 87,600.

M16 Stainless Steel Hardware

All external hardware is provided in stainless steel.

Applicable Series
48,100
56,X00 & 87,X00
81,000; 82,000 & 86,000

M17 Terminal Strip

A terminal strip is located in the inside of the brake, on the support plate. It allows for easy connection and identification of lead wires.

Applicable Series
All

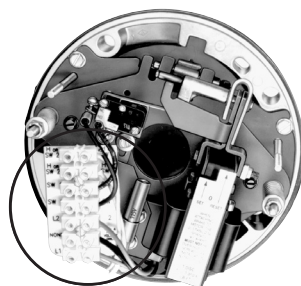

56,000 Series

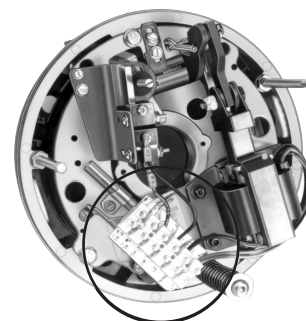

87,000 Series (also representative of 81,000; 82,000 & 86,000 Series)

M18 Thermostat (Thermal) Switch

This switch is used to indicate when a brake is overheating. Thermostats are standard in 8X,300 and 65,X00 Series. This option is for NON-UL brakes only.

Applicable Series	Switch Operation Specifications
87,X00	Normally Closed: Opens at 295°F, Closes at 255°F
81,000; 82,000 & 86,X00	Normally Closed: Opens at 210°F, Closes at 180°F
56,X00	Normally Closed: Opens at 195°F, Closes at 175°F



M19 Through-Shaft Enclosure

This configuration allows for the motor shaft to extend beyond the housing of the brake.

Brakes are IP 23 before adding through shaft; after adding through shaft, brakes are IP 20.

*Up to 1-5/16". Above 1-5/16", contact factory for pricing.

Applicable Series
56,000 & 56,400
56,100 & 56,200
56,600
81,000 & 82,000
86,000
87,000 & 87,100 sheet metal*
87,000 & 87,100 with cast iron housing



M20 Through-Shaft Cast Iron Enclosure with Lip Seal

This configuration allows the motor shaft to extend beyond the housing of the brake with a bushing to use with a housing lip seal.

Brakes are IP 56 with motor to endplate gasket installed; IP 54 without. After adding through shaft, brakes are IP 40.

Applicable Series
56,100; 56,200 & 56,600
81,000 & 82,000
86,000
87,000 & 87,100



M21 Vertical Mounting for 56,000 Series & 65,300 Series

The 56,000 series 20 and 25 lb-ft brakes are shipped with spring kits. Vertical modification at 15° from horizontal. Read installation and service instructions for details on its use.

The 65,300 series 10 and 15 lb-ft brakes are shipped with spring kits. Vertical modification standard for multi-disc brakes.

Factory assembly for three disc configuration; contact factory for pricing.

3 Friction Disc Brake

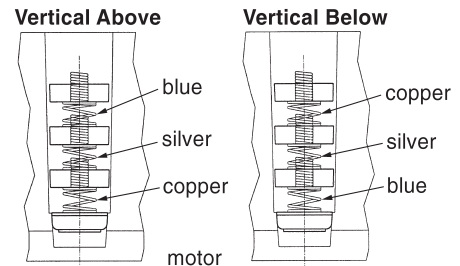

Example of 56,000 Series spring requirements for vertical above and below mounting.

M23 Vertical Mounting for 87,X00 Series

For factory modification to vertical above or below application. Vertical modification at 15° from horizontal.

Series 87,000 & 87,100

Torque Value (lb-ft)	IP 23 & IP 54/56* Steel Hsg Above	IP 23 & IP 54/56* Steel Hsg Below	IP 54/56* Cast Iron Above	IP 54/56* Cast Iron Below
6, 10, 15, 25 & 35	Contact factory for pricing			
50 & 75	Contact factory for pricing			
105	Contact factory for pricing			

Series 87,300; 87,800 & 87,700

Torque Value (lb-ft)	Vertical Above	Vertical Below
6, 10, 15, 25 & 35	Contact factory for pricing	
50 & 75	Contact factory for pricing	
105	Contact factory for pricing	

* IP 54; IP 56 with motor gasket.

3 Friction Disc Brake

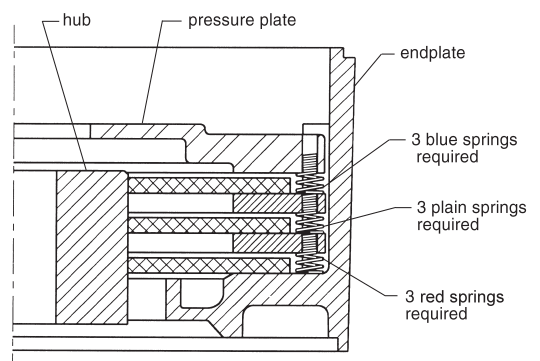

Example of 87,000 Series spring requirements for vertical above mounting.

M24 Vertical Mounting for 81,000; 82,000 & 86,000 Series

These brakes require factory modifications for vertical applications. Vertical modification at 15° from horizontal.

Applicable Series	Torque Value (lb-ft)
81,000 & 82,X00	125 & 175
81,000 & 82,X00	230
82,X00	330
82,X00	440
86,000	500 & 750

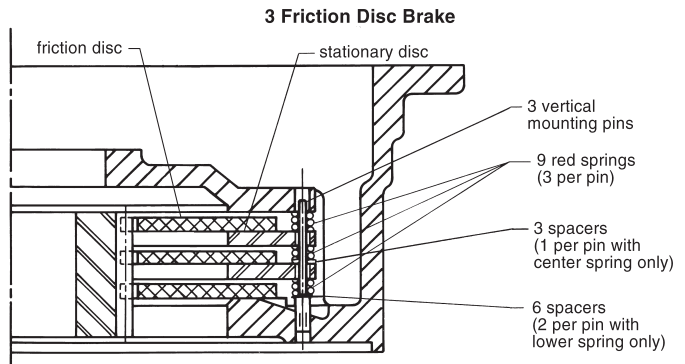

Example of 81,000 Series pin, spring and spacer requirements for vertical above mounting.

M27 Wear Indicator (Friction Disc) Switch

A mechanical switch is installed to indicate when the friction disc requires replacement.

Applicable Series
81,000 & 82,X00
86,000
87,X00*

*Switch supplied with leads. Not available on 87,800 brakes.

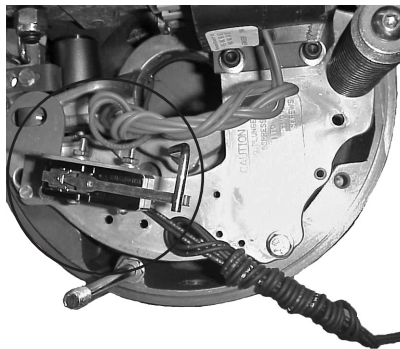

87,000 Assembly

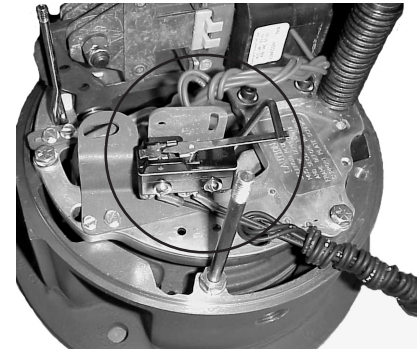

87,000 Assembly

M29 Special Shaft-Coupler Brake & Foot Mount Brake

Any non-standard input or output shaft on a 56,700; 87,200 or 87,700 series brake.

Applicable Series
56,700
87,200 & 87,700



M30 Taper-Lock Hubs

For use in severe duty applications and reversing application to secure the brake hub to the motor shaft.

Series	Lb. Ft.
87,000 & 87,100 IP 23 only	10 to 35 lb-ft
	50 to 75 lb-ft
	105 lb-ft
81,000	125 & 175 lb-ft
	230 lb-ft
82,000	125 & 175 lb-ft
	230 & 330 lb-ft
	440 lb-ft



M32 Non-Maintained (Deadman) Manual Release

The brake is mechanically released while the release is pulled into a release position. Once released, the brake sets.

Applicable Series*
56,200; 56,700; 56,800 & 56,900
56,000; 56,400 & 56,500
81,000; 82,000 & 87,000
86,000

*Not available on 56,300 Series. Standard on 56,100 and 56,600 brakes.



M33 Metric Machining Including Cast Iron Endplate

Stearns SABs can be used with metric motor frames. The following table indicates standard frame capabilities for an IEC B14 face mount.

Applicable Series	IEC Frame Sizes
56,200; 56,400; 56,600 & 56,900	B14 flange in sizes 80; 90 & 100 B5 flange in sizes D63 & D71
56,500	B14 flange in sizes 112; 132 & 160 B5 flange in sizes D71; D80; D90; D100 & D112
87,000	B14 flange in sizes 112; 132 & 160 B5 flange in sizes D71; D80; D90; D100 & D112

M35 Special Internal Lead Wire Hole with Bushing

Any non-standard, internal lead wire hole in the endplate.

Applicable Series
All brakes except hazardous location brakes



M36 Housing Split

SABs can be provided with a split housing; this will reduce the IP rating to IP 40. IP rating will not be reduced if gasketed.

Applicable Series
81,000; 82,000 & 86,000
81,000; 82,000 & 86,000 gasketed
87,000 & 87,100 sheet metal
87,000 & 87,100 cast iron gasketed

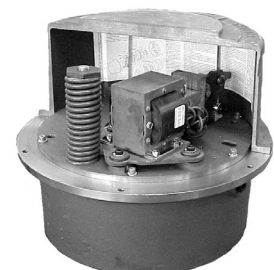

M37 Internal Release

An internal manual release requires that the housing be removed before the brake can be released by hand.

Applicable Series*

87,0XX; 81,0XX;
82,0XX & 86,0XX

*Not available for hazardous location brakes.

M39 Corrosion-Resistant Endplate

Rust preventative treatment applied to brake endplate.

Applicable Series

56,200; 56,400; 56,500; 56,800 & 65,300
81,000; 82,X00 & 86,000
87,X00



M40 Special Milling: Flat Bottom on Housing & Endplate

This modification is provided in the event the flange between the endplate and housing interferes with the mounting configuration.

Applicable Series

81,000; 82,000 & 86,000



M41 Brass Nameplate with Special Engraving

Brass nameplates offer greater durability in outdoor applications.

Applicable Series

81,000; 82,000 & 86,000

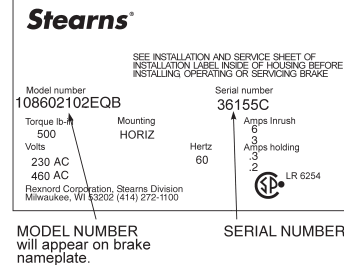

M42 Stainless Splined Hub

Stainless steel splined hubs are available for extreme outdoor applications, to prevent corrosion on the disc and hub interface.

Applicable Series

81,000; 82,000 & 86,000
87,000



M43 Viton® Gasket

Gaskets and o-rings in brakes can be provided in Viton® (fluorocarbon) material, in place of the standard neoprene. However, the V-wiper steel-backed seals that are used on pull rod manual releases are not available in Viton® and remain as neoprene.

Viton® is a registered trademark name of DuPont.

Applicable Series

81,000; 82,000 & 86,000
87,000*
56,000**

*Viton® gaskets and o-rings are standard for 87,X00 series, except for hazardous location brakes where Viton® seals are not available.

**Except series 56,200; 56,700 & 56,900 - where Viton gaskets are standard.

M44 Special Friction Disc (per Disc)

Any non-standard friction disc in a brake.
Cost is per disc.

Non-standard discs include: hi-inertia friction discs and heavy duty friction discs. Does not include carrier ring friction discs (see M46 and M47).

Applicable Series
87,000

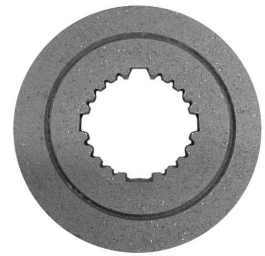

M45 Splined Hub & Friction Disc

Standard on most models. Used for severe duty and reversing applications.

Applicable Series
87,300

Applicable Series	Torque (lb-ft)
87,X00*	6-35 lb-ft
	50 & 75 lb-ft
	105 lb-ft

*Spline is standard on this series.

M46 Carrier Ring Friction Disc

The friction material is bonded to a steel or zinc/aluminum alloy ring. This is used for severe duty applications and applications where people are being moved.

Applicable Series	Carrier ring material
Horizontal Use Only	
81,000	Steel
82,000	Steel
Horizontal or Vertical Use	
87,X00*	Zinc aluminum alloy

*Not available on 87,300 or 87,800 series.

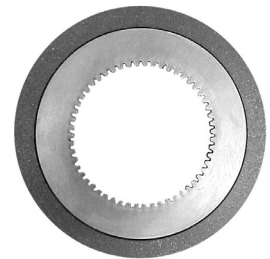

M47 Carrier Ring Friction Disc (Bronze)

The friction material is bonded to a bronze ring. This is used for severe duty applications and applications where people are being moved.

Horizontal applications only.

*Only available with pre-revision design, 24-tooth splined hub.

Applicable Series
81,000
82,000
86,000
87,X00*
6-35 lb-ft
50 & 75 lb-ft
105 lb-ft



M48 1,08X,000 Series Manual Adjust Mechanism

Excellent for holding applications when disc wear is not a concern. Not available on hazardous location brakes.

Applicable Series
87,000
81,000
82,000
86,000

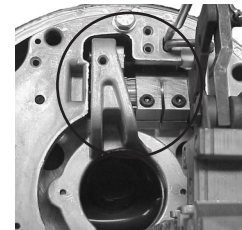

M60 Encoders

Internally mounted encoders are available in some series brakes, including some hazardous location brakes. See encoder brakes section for series availability and additional information.

Maximum Encoder Diameter (in.)	
1-056	N/A
1-087-E00	2.0"
1-081 & 1-082	2.5"
1-086	3.5"

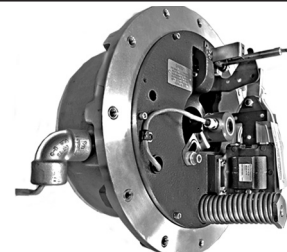

Technical Data

SAB Motor Frame Adapter Dimensions Selection

To select an adapter for a specific brake, refer to the motor frame adapter tables as shown in the brake series sections of this catalog. After selecting the adapter stock number, refer to the Tables below for dimensions.

All adapters are constructed with an opening for internal lead wire connection, corresponding to the NEMA standard location for the motor frame size.

Screws for mounting adapter to motor must be provided by customer. Socket head cap screws are supplied for mounting brake to adapter.

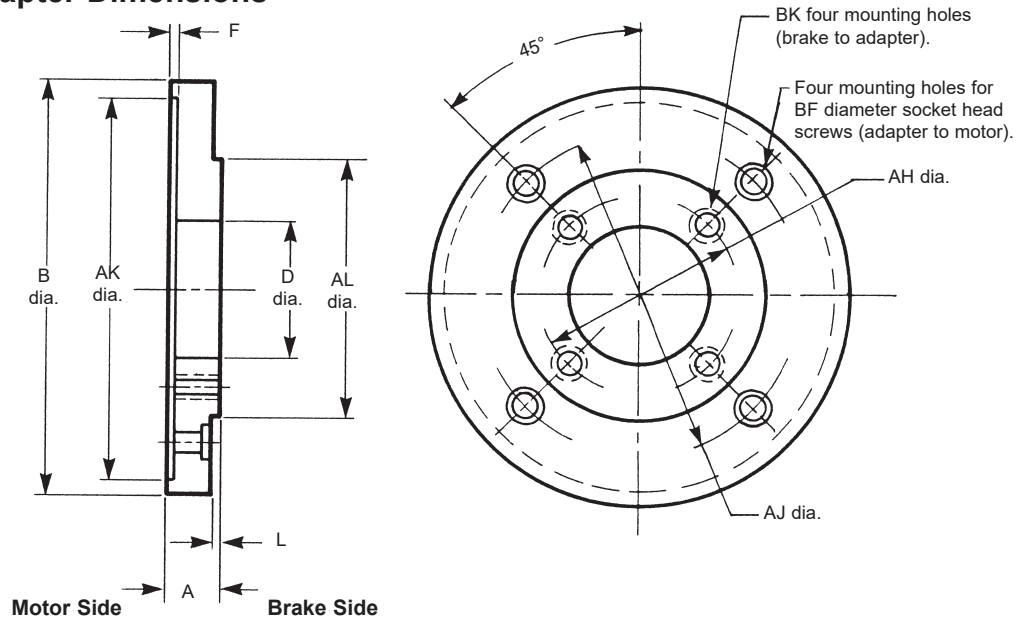

Dimensions for estimating only. For installation purposes, request certified prints.

Brake Series	Torque (lb-ft)	Adapter Stock Number	Dimensions in Inches (Dimensions in Millimeters)											Add'l Shaft Length Req'd			
			A	AH	AJ	AK	AL	B	BF	BK Hole	D	F	L				
56,000	1.5 - 6	5-55-5041-00				8.500	4.497										
65,300*		5-55-5046-00	1.25 (31.75)	5.88 (149.22)	7.25 (184.15)	8.502 (215.900) (215.951)	4.500 (114.325) (114.275)	9.00 (228.60)	.50 (12.70)	3/8 - 16 x 1/2 deep	4.00 (101.60)	.19 (4.76)	.12 (3.18)	.94 (23.88)			
56,000 and 56,800*	10 - 25	5-55-5043-00															
87,000 and 87,800*	6 - 105	5-55-7046-00	1.06 (26.99)		11.00 (279.40)	12.501 (317.525) (317.602)	8.499 (215.875) (215.849)	13.00 (330.20)	.62 (15.88)			4.12 (104.78)		.38 (9.52)	.87 (22.10)		
87,300		5-55-7054-00		7.25 (184.15)						1/2 - 13 through		.19 (4.76)					
87,000 and 87,800*	6 - 105	5-55-7055-00	1.00 (25.40)		9.00 (228.60)	10.500 (266.700) (266.751)	8.499 (215.875) (215.849)	11.00 (279.40)	**		6.25 (158.75)		.25 (6.35)	.81 (20.57)			
87,300*		5-55-7045-00															
87,000, 87,800* and 87,300*	6 - 105	5-55-7043-00	.75 (19.05)	7.25 (184.15)	5.88 (149.35)	4.502 (114.35) (114.48)	8.499 (215.875) (215.849)	8.75 (222.25)	.62 (15.75)	1/2 - 13 through	4.00 (101.60)	.19 (4.76)	.25 (6.35)	.56 (14.23)			
81,000	125 - 130	5-55-2045-00	1.06 (26.99)	11.00 (279.40)	14.00 (355.60)	16.002 (406.451) (406.527)	12.499 (317.475) (317.398)	16.50 (419.10)	.62 (15.88)	5/8 - 11 through	9.75 (247.65)	.19 (4.76)	.25 (6.35)	.87 (22.10)			
81,000	125 - 230	5-55-2041-00			7.25 (184.15)	8.500 (215.900) (215.951)	12.499 (317.475) (317.398)	12.496 (317.475) (317.398)	.50 (12.70)	5/8 - 11 through	6.00 (152.40)		.19 (4.76)	.93 (23.62)			
81,000		5-55-2043-00	1.12 (28.58)	11.00 (279.40)	9.00 (228.60)	10.500 (266.700) (266.751)	12.496 (317.398)	12.496 (317.398)			7.75 (196.85)			.93 (23.62)			
82,000 and 82,300*	125 - 440	5-55-2046-00	1.94 (49.21)		14.00 (355.60)	16.002 (406.451) (406.527)		16.50 (419.10)	.62 (15.88)	5/8 - 11 x 1 deep	9.50 (241.30)			1.75 (44.45)			
82,000 and 82,300*		5-55-2042-00	1.38 (34.92)	11.00 (279.40)	7.25 (184.15)	8.500 (215.900) (215.951)	12.496 (317.475) (317.398)	13.25 (336.55)	.50 (12.70)	5/8 - 11 through	6.00 (152.40)	.19 (4.76)	.25 (6.35)	1.19 (30.23)			
82,000 and 82,300*		5-55-2044-00	1.38 (34.92)		9.00 (228.60)	10.500 (266.700) (266.751)		13.25 (336.55)			7.75 (196.85)			1.19 (30.23)			
86,000	500 - 1000	5-55-6041-00	1.56 (38.69)	14.00 (355.60)	11.00 (279.40)	12.500 (317.500) (317.602)	16.000 (406.400) (406.273)	16.19 (411.16)	.62 (15.88)	5/8 - 11 x 3/4 deep	8.62 (219.08)	.19 (4.76)	.25 (6.35)	1.37 (34.80)			

* 1/2-13 flat head screws are supplied with adapter.

** When adding an adapter to a hazardous location brake, refer to the "mounting requirements" on the product page for the recommended brake series for accommodating adapters.

Foot Mounting Kits

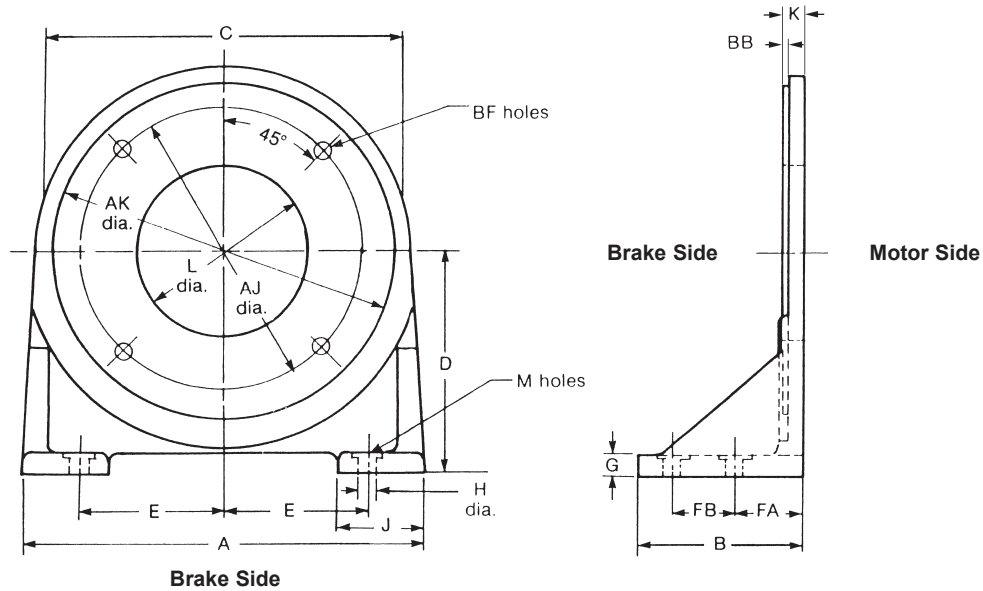

Kits include the foot mounting bracket and hardware to fit the BF mounting holes.

Dimensions for estimating only. For installation purposes, request certified prints.

Brake Series	Torque	Foot Mounting Kit Number	Dimensions in Inches (Dimensions in Millimeters)																	Wgt lbs.	
			A	AJ	AK	B	BB	BF		C	D	E	FA	FB	G	H	J	K	L		M
								No.	Thd.												
56,000	1.5-25	5-55-5023-00	7.00 (177.80)	5.88 (149.22)	$\frac{4.499}{4.498}$ ($\frac{114.275}{114.249}$)	2.38 (60.32)	.12 (3.18)	2	3/8-16	6.50 (165.10)	3.50 (88.90)	2.88 (73.02)	1.50 (38.10)	-	.38 (9.52)	.41 (10.32)	1.50 (38.10)	.50 (12.70)	2.50 (63.50)	2	4.5
87,000	6-125	5-55-7021-00	8.62 (219.08)	7.25 (184.15)	$\frac{8.499}{8.498}$ ($\frac{215.875}{215.849}$)	3.00 (76.20)	.25 (6.35)	4	1/2-13	8.62 (218.95)	5.00 (127.00)	3.56 (90.49)	2.00 (50.80)	-	.38 (9.52)	.53 (13.49)	1.62 (41.28)	.56 (14.29)	5.75 (146.05)	2	7
81,000	125-230	5-55-2022-00	15.50 (393.70)	11.00 (279.40)	$\frac{12.499}{12.498}$ ($\frac{317.475}{317.449}$)	7.00 (177.80)	.25 (6.35)	4	5/8-11	13.25 (336.55)	8.50 (215.90)	6.88 (174.62)	2.00 (50.80)	4.00 (101.60)	.62 (15.88)	.69 (17.46)	3.00 (76.20)	.88 (22.22)	9.00 (228.60)	4	40
82,000	125-550		18.25 (463.55)	14.00 (355.60)	$\frac{16.000}{15.995}$ ($\frac{406.400}{406.273}$)	8.00 (203.20)	.22 (5.56)	4	5/8-11	17.00 (431.80)	10.88 (276.22)	6.38 (161.92)	3.38 (85.72)	3.00 (76.20)	1.00 (25.40)	.81 (20.64)	4.12 (104.78)	1.22 (30.96)	8.50 (215.90)	4	75

Dimensions for C-Face Brake Motor Systems

Brakes Externally Wired to Motor
C-face motor with double shaft extension.

Stearns disc brakes are designed to mount on standard C-face motors having the same dimensions and tolerances on the accessory end as on the drive end. They also mount on foot mounting brackets and machine mounting faces having the same mounting dimensions and tolerances. Some motor accessory end C-face may differ from the drive end.

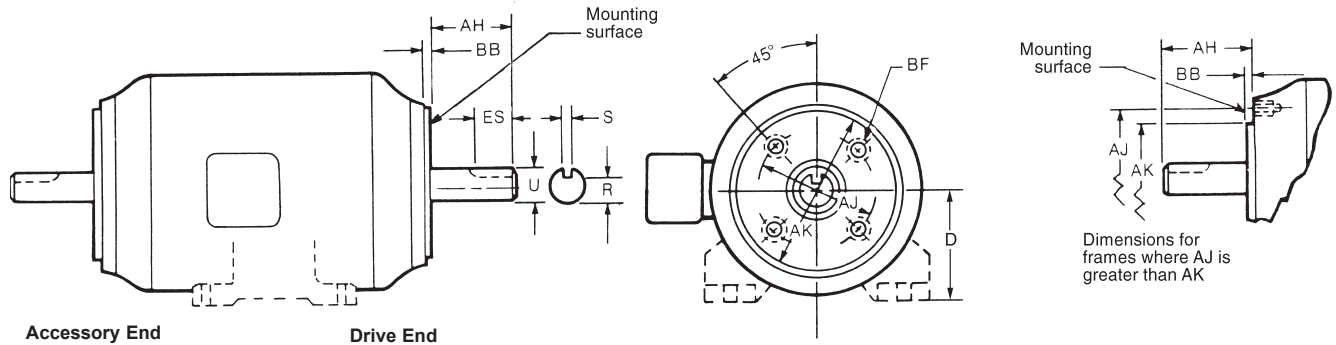

Drive End Dimensions (Inches)

Frame Designation	AJ	AK	BB Min.	BF Hole			U	AH	Keyseat			Base to Centerline D
				Number	Tap Size	Bolt Penetration Allowance			R	ES Min.	S	
42C	3.750	3.000	0.16	4	1/4-20	...	0.375	1.312	0.328	...	flat	2.62
48C	3.750	3.000	0.16	4	1/4-20	...	0.500	1.69	0.453	...	flat	3.00
56C	5.875	4.500	0.16	4	3/8-16	...	0.625	2.06	0.517	1.41	0.188	3.50
143TC and 145TC	5.875	4.500	0.16	4	3/8-16	0.56	0.875	2.12	0.771	1.41	0.188	3.50
182TC and 184TC	7.250	8.500	0.25	4	1/2-13	0.75	1.125	2.62	0.986	1.78	0.250	4.50
182TCH and 184TCH	5.875	4.500	0.16	4	3/8-16	0.56	1.125	2.62	0.986	1.78	0.250	4.50
213TC and 215TC	7.250	8.500	0.25	4	1/2-13	0.75	1.375	3.12	1.201	2.41	0.312	5.25
254TC and 256TC	7.250	8.500	0.25	4	1/2-13	0.75	1.625	3.75	1.416	2.91	0.375	6.25
284TC and 286TC	9.000	10.500	0.25	4	1/2-13	0.75	1.875	4.38	1.591	3.28	0.500	7.00
284TSC and 286TSC	9.000	10.500	0.25	4	1/2-13	0.75	1.625	3.00	1.416	1.91	0.375	7.00
324TC and 326TC	11.000	12.500	0.25	4	5/8-11	0.94	2.125	5.00	1.845	3.91	0.500	8.00
324TSC and 326TSC	11.000	12.500	0.25	4	5/8-11	0.94	1.875	3.50	1.591	2.03	0.500	8.00
364TC and 365TC	11.000	12.500	0.25	8	5/8-11	0.94	2.375	5.62	2.021	4.28	0.625	9.00
364TSC and 365TSC	11.000	12.500	0.25	8	5/8-11	0.94	1.875	3.50	1.591	2.03	0.500	9.00
404TC and 405TC	11.000	12.500	0.25	8	5/8-11	0.94	2.875	7.00	2.450	5.65	0.750	10.00
404TSC and 405TSC	11.000	12.500	0.25	8	5/8-11	0.94	2.125	4.00	1.845	2.78	0.500	10.00
444TC and 445TC	14.000	16.000	0.25	8	5/8-11	0.94	3.375	8.25	2.880	6.91	0.875	11.00
444TSC and 445TSC	14.000	16.000	0.25	8	5/8-11	0.94	2.375	4.50	2.021	3.03	0.625	11.00
500 Frame Series	14.500	16.500	0.25	4	5/8-11	0.94	12.50

Tolerances (Inches)

AK Dimension, Face Runout, Permissible Eccentricity of Mounting Rabbet

AK Dimension	Tolerance on AK Dimension		Maximum Face Runout	Maximum Permissible Eccentricity of Mounting Rabbet
	Plus	Minus		
Less than 12	0.000	0.003	0.004	0.004
12 and Larger	0.000	0.005	0.007	0.007

Shaft Extension Diameters

Shaft Diameter	Tolerances	
	Plus	Minus
0.2500 to 1.5000, inclusive	0.000	0.0005
Over 1.5000 to 6.500, inclusive	0.000	0.001

Width of Shaft Extension Keyseats

Width of Keyseat	Tolerances	
	Plus	Minus
0.188 to 0.750, inclusive	0.002	0.000
Over 0.750 to 1.500, inclusive	0.003	0.000

Shaft Runout

Shaft Diameter	Maximum Permissible Shaft Runout
0.3750 to 1.625, inclusive	0.002
Over 1.625 to 6.500, inclusive	0.003

SOURCE: ANSI/NEMA Standards Publication No. MG 1-1987; Part 4 and Part 11.

Dimensions for C-Face AC Brake Motor Systems Continued

Accessory End

FC face mounting for accessories, including brakes, on the end opposite the drive end of motor. Some motor accessory end C-face may differ from the drive end. Confirm shaft diameter and bolt circle before ordering.

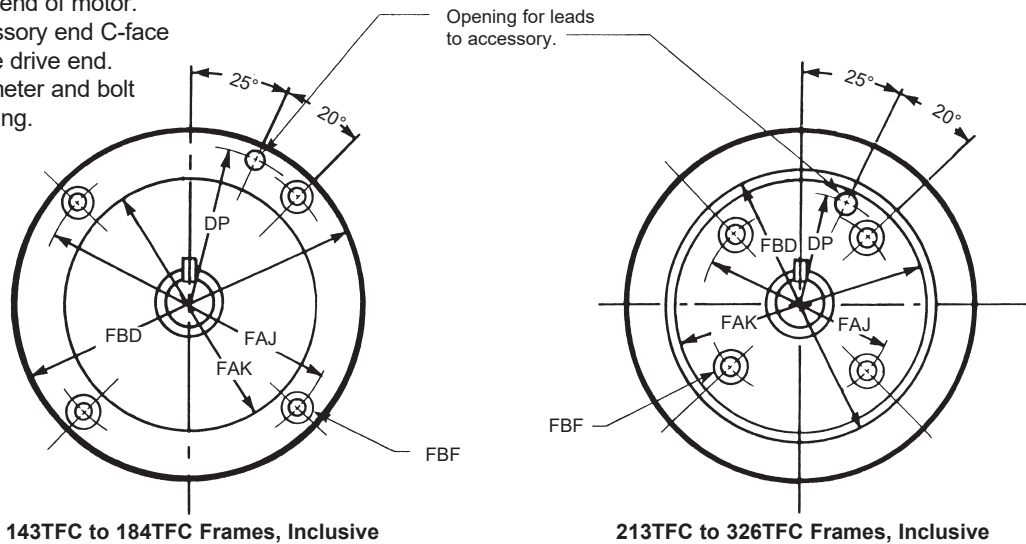

Dimensions (Inches)

Frame Designation	FAJ	FAK	FBD Max.	FBF Hole			Hole for Accessory Leads	
				Number	Tap Size	Bolt Penetration Allowance	DP	Diameter
143TFC and 145TFC	5.875	4.500	6.50	4	3/8-16	0.56	2.81	0.41
182TFC and 184TFC	5.875	4.500	6.50	4	3/8-16	0.56	2.81	0.41
213TFC and 215TFC	7.250	8.500	9.00	4	1/2-13	0.75	3.81	0.62
254TFC and 256TFC	7.250	8.500	10.00	4	1/2-13	0.75	3.81	0.62
284TFC and 286TFC	9.000	10.500	11.25	4	1/2-13	0.75	4.50	0.62
324TFC and 326TFC	11.000	12.500	14.00	4	5/8-11	0.94	5.25	0.62

NOTE: Standards have not been developed for the shaft extension diameter and length, and keyseat dimensions.

Tolerances* (Inches)

FAK Dimension, Face Runout, Permissible Eccentricity of Mounting Rabbet

FAK Dimension	Tolerance on FAK Dimension		Maximum Face Runout	Maximum Permissible Eccentricity of Mounting Rabbet
	Plus	Minus		
Less than 12	0.000	0.003	0.004	0.004
12 and Larger	0.000	0.005	0.007	0.007

* Tolerance requirement on 56,X00 and 87,000 Series brake kits is .015 T.I.R. (total indicated runout shaft to motor register face).

Shaft Runout

Shaft Diameter	Maximum Permissible Shaft Runout
0.3750 to 1.625, inclusive	0.002
Over 1.625 to 6.500, inclusive	0.003

SOURCE: ANSI/NEMA Standards Publication No. MG 1-1987; Part 4 and Part 11.

Stearns Recommended Minimum Shaft Diameter by Torque

Minimum recommended shaft size considers a keyed C1045 steel shaft under *dynamic* use in a typical spring set brake application.

Torque ft-lb	Minimum Shaft (inches)
0.50	0.250
0.75	0.250
1.5	0.375
3	0.500
6	0.500
10	0.625
15	0.750
25	0.875
35	1.000
50	1.125

Torque ft-lb	Minimum Shaft (inches)
75	1.250
105	1.375
125	1.375
175	1.625
230	1.750
330	2.000
440	2.125
500	2.375
750	2.500
1000	2.750

Torque Nm	Minimum Shaft (mm)
4 Nm	ø10 mm
8 Nm	ø13 mm
16 Nm	ø16 mm
32 Nm	ø20 mm
60 Nm	ø25 mm
80 Nm	ø28 mm
150 Nm	ø34 mm
240 Nm	ø39 mm
400 Nm	ø47 mm

Set & Release Times

The models listed below were tested for typical set and release times. Times listed below are defined as follows:

T1 = Total set time to 80% of rated static torque T2 = Release time, measured as the time from when the power is applied to the brake to the time that the solenoid plunger or armature is fully seated.

NOTE: Times will vary with the motor used, and brakes tested with factory-set air gap. The times shown should be used as a guide only.

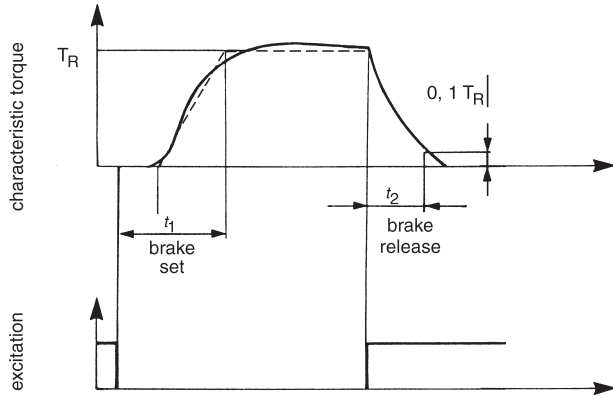

SAB T1/T2 Time in Milliseconds

Series	Static Torque lb-ft	Coil Size	Coil Strength	T1 AC	T2 AC
56,000	1 1/2 – 25	4	3	25	14
87,000	10,15, 25,50	5 & 6	3	53	21
87,000	35,75,105	8	3	50	25
81,000 82,000	All	9	3	58	31

Brake and motor are switched separately.
All brakes tested in horizontal position.
Coil is energized for >24 hours before testing.
Ambient temperature 70°F at time of test.

AAB Series 333 Times in Milliseconds

Size	Applied Voltage/Type of Switching	T1	T2
72	DC side switching	23	35
	230 Vac/ac side switching/full wave	103	39
	460 Vac/ac side switching/half wave	98	34
90	DC side switching	19	73
	230 Vac/ac side switching/full wave	113	72
	460 Vac/ac side switching/half wave	114	73
	230 Vac connected across motor full wave	357	72
112	230 Vac connected across motor /quickset	42	72
	DC side switching	155	39
	230 Vac/ac side switching/full wave	547	43
	460 Vac/ac side switching/half wave	501	54
132	DC side switching	119	100
	230 Vac/ac side switching/full wave	833	101
	460 Vac/ac side switching/half wave	803	106
145	DC side switching	185	186
	230 Vac/ac side switching/full wave	999	192
	460 Vac/ac side switching/half wave	1007	209
	230 Vac connected across motor full wave	1689	192
	230 Vac connected across motor /quickset	368	192
170	460 Vac/ac side switching/half wave/With air gap shim	629	223
	DC side switching	129	163
	230 Vac/ac side switching/full wave	1130	174
	460 Vac/ac side switching/half wave	1140	175
196	DC side switching	96	263
	230 Vac/ac side switching/full wave	920	264
	460 Vac/ac side switching/half wave	957	274
230	DC side switching	131	264
	230 Vac/ac side switching/full wave	1299	236
	460 Vac/ac side switching/half wave	1303	276
	Tor-Ac 230 Vac/ac side switching/full wave	169	295
	Tor-Ac 230 Vac/ac side switching/full wave/With air gap shim	122	327
	230 Vac connected across motor quickset/quickrelease/with air gap shim	122	145
278	DC side switching	182	388
	230 Vac/ac side switching/full wave	1807	389
	460 Vac/ac side switching/half wave	1689	366

AAB Series 310/311/320/321 Times in Milliseconds

Series	310 DC Side Switching					
Size	1.79	2.0	2.87	3.35	4.25	5.0
T1	3	6	9	14	13	22
T2	20	43	48	110	120	195
Series	311 DC Side Switching					
Size	3.38	4.75	5.0			
T1	43	48	96			
T2	12	74	35			
Series	320 DC Side Switching					
Size	1.2	1.8	2.0	2.8		
T1	14	43	16	27		
T2	24	26	35	34		
Series	320 Full wave rectifier/AC Side Switching					
Size	1.2	1.8	2.0	2.8		
T1	31	97	52	78		
T2	27	29	40	42		
Series	321 DC Side Switching			321 AC Side Switching		
Size	1.2	1.8	2.8	1.2	1.8	2.8
T1	13	16	20	45	77	131
T2	18	27	49	16	25	26

Conversions

English-Metric Conversion Factors

Multiply the base unit by the factor shown to obtain the desired conversion.

Measurement	Base Unit	Factor	Conversion
Length	inch, in	25.4	(<i>millimeter, mm</i>)
	(<i>millimeter, mm</i>)	.03937	inch, in
Torque	pound-feet, lb-ft	1.355818	(<i>newton-meter, Nm</i>)
	(<i>newton-meter, Nm</i>)	.73756	pound-feet, lb-ft
	pound-inch, lb-in	.113	(<i>newton-meter, Nm</i>)
	(<i>newton-meter, Nm</i>)	8.85	pound-inch, lb-in
	ounce-inch, oz-in	.007062	(<i>newton-meter, Nm</i>)
	(<i>newton-meter, Nm</i>)	141.611	ounce-inch, oz-in
Moment of Inertia	pound-feet squared, lb-ft ²	.04214	(<i>kilogram-meter squared, kgm²</i>)
	(<i>kilogram-meter squared, kgm²</i>)	23.73	pound-feet squared, lb-ft ²
Kinetic Energy	foot-pound, ft-lb	1.355818	(<i>joule, J</i>)
	(<i>joule, J</i>)	.73756	foot-pound, ft-lb
Weight	pound, lb	.453592	(<i>kilogram, kg</i>)
	(<i>kilogram, kg</i>)	2.20462	pound, lb
Horsepower (English)	horsepower, hp	.7457	(<i>kilowatt, kW</i>)
	(<i>kilowatt, kW</i>)	1.341	horsepower, hp
Thermal Capacity	horsepower-seconds per minute, hp-sec/min	12.42854	(<i>watts W</i>)
	(<i>watts, W</i>)	.08046	horsepower-seconds per minute, hp-sec/min
Temperature	degrees Fahrenheit, °F	(°F - 32) x 5/9	(<i>degrees Celsius, °C</i>)
	(<i>degrees Celsius, °C</i>)	(°C x 9/5) + 32	degrees Fahrenheit, °F

English-English Conversion Factors for Thermal Capacity

Base Unit	Multiply by	To Obtain
horsepower	60.0	hp-sec/min
ft-lb/sec	.109	hp-sec/min
ft-lb/min	.0018	hp-sec/min
in-lb/sec	.009	hp-sec/min
in-lb/min	.00015	hp-sec/min

Decimal Equivalents of Fractions

Decimal Equivalent (Inches)		Fraction (Inches)
2-Place	3-Place	
.02	.016	1/64
.03	.031	1/32
.05	.047	3/64
.06	.062	1/16
.08	.078	5/64
.09	.094	3/32
.11	.109	7/64
.12	.125	1/8
.14	.141	9/64
.16	.156	5/32
.17	.172	11/64
.19	.188	3/16
.20	.203	13/64
.22	.219	7/32
.23	.234	15/64
.25	.250	1/4
.27	.266	17/64
.28	.281	9/32
.30	.297	19/64
.31	.312	5/16
.33	.328	21/64
.34	.344	11/32
.36	.359	23/64
.38	.375	3/8

Decimal Equivalent (Inches)		Fraction (Inches)
2-Place	3-Place	
.39	.391	25/64
.41	.406	13/32
.42	.422	27/64
.44	.438	7/16
.45	.453	29/64
.47	.469	15/32
.48	.484	31/64
.50	.500	1/2
.52	.516	33/64
.53	.531	17/32
.55	.547	35/64
.56	.562	9/16
.58	.578	37/64
.59	.594	19/32
.61	.609	39/64
.62	.625	5/8
.64	.641	41/64
.66	.656	21/32
.67	.672	43/64
.69	.688	11/16
.70	.703	45/64
.72	.719	23/32
.73	.734	47/64
.75	.750	3/4

Decimal Equivalent (Inches)		Fraction (Inches)
2-Place	3-Place	
.77	.766	49/64
.78	.781	25/32
.80	.797	51/64
.81	.812	13/16
.83	.828	53/64
.84	.844	27/32
.86	.859	55/64
.88	.875	7/8
.89	.891	57/64
.91	.906	29/32
.92	.922	59/64
.94	.938	15/16
.95	.958	61/64
.97	.969	31/32
.98	.984	63/64
1.00	1.000	1

Application Engineering

Introduction

Information and guidelines provided in the application section are intended for general selection and application of spring set brakes. Unusual operating environments, loading or other undefined factors may affect the proper application of the product. Stearns application services are available to assist in proper selection or to review applications where the specifier may have questions.

A spring set brake is used to stop and hold a rotating shaft. Generally the brake is mounted to an electric motor, but can also be mounted to gear reducers, hoists, machinery or utilize a foot mount kit.

The brake should be located on the high speed shaft of a power transmission system. This permits a brake with the lowest possible torque to be selected for the system.

Spring set disc brakes use friction to stop (dynamic torque) and hold (static torque) a load. Energy of the motor rotor and moving load is converted to thermal energy (heat) in the brake during deceleration. The brakes are power released, spring applied. No electrical current is required to maintain the spring set condition.

The system designer will need to consider the mount surface and match the brake to the load and application. Factors include: brake torque, stopping time, deceleration rate, load weight and speed, location and environment. Brake thermal ratings, electrical requirements and environmental factors are discussed in separate sections.

Electrical Considerations

Solenoid actuated brakes (SAB) are available with standard motor voltages, frequencies and Class B or H coil insulation. Most models can be furnished with either single or dual voltage coils. Coils in most models are field replaceable.

Inrush and holding amperage information is published for the common coil voltages and factory available for other voltages or frequencies. Amperage information for specific coil sizes is provided for selection of wire size and circuit protection at brake installation. Fixed voltage - 50/60 Hz dual frequency coils are available in many models.

All SAB AC coils are single phase and can be wired to either single or three phase motors without modifications. All solenoid coils have a voltage range of +/- 10% of the rated nameplate voltage at the rated frequency. Instantaneous rated voltage must be supplied to the coil to insure proper solenoid pull in and maximum coil cycle rate. The plunger rapidly seats in the solenoid and the

amperage requirements drops to a holding amperage value.

Instantaneous voltage must be supplied to the coil to insure proper solenoid pull-in and maximum coil cycle rate.

Since Stearns SABs require low current to maintain the brake in the released position, the response time to set the brake *can* be affected by EMF voltages generated by the motor windings. It may be necessary to isolate the brake coil from the motor winding.

The solenoid coil cycle rate limits the engagements per minute of a static or holding duty brake. Brake thermal performance, discussed in another section, limits engagements per minute in dynamic applications.

Class B insulation is standard in most SAB models, class H coil insulation is optional and is recommended for environments above 104°F (40°C), or rapid cycling applications.

Armature actuated brakes (AAB) are available in standard DC voltages. Available AC rectification is listed in the catalog section. Wattage information is provided in the catalog pages. Unlike solenoid actuated brakes, armature actuated brakes do not have inrush amperage. Coil and armature reaction time and resulting torque response time information is available. Like SAB, mechanical reaction time depends on typical application factors including load, speed and position.

Electrical response time and profiles are unique to the SAB and AAB. Reaction time requirements should be considered when selecting or interchanging brakes.

All Stearns brake coils are rated for continuous duty and can be energized continually without overheating. The coil heating effect is greatest at coil engagement due to engaging, pull in or inrush amperage.

Temperature limits as established by UL controls standards are:

Class A insulation	221°F (105°C)
Class B insulation	266°F (130°C)
Class H insulation	356°F (180°C).

Types of Applications

In order to simplify the selection of a disc brake, loads can be classified into two categories, non-overhauling and overhauling.

Loads are classified as non overhauling, if (1) no components of the connected equipment or external material undergo a change of height, such as would occur in hoisting, elevating or lowering a load, and (2) there is only rotary motion in a horizontal plane. For example, a loaded conveyor operating in a horizontal plane would be typical of a non-overhauling load.

If the same conveyor were transporting material to a lower level, it would be classified as an overhauling load. The external material or load undergoes a change in height, with the weight of the load attempting to force the conveyor to run faster than its design speed or to overhaul.

Non-overhauling loads require braking torque only to stop the load and will remain at rest due to system friction. Overhauling loads, such as a crane hoist, have two torque requirements. The first requirement is the braking torque required to *stop* the load, and the second requirement is the torque required to *hold* the load at rest. The sum of these requirements is considered when selecting a brake for an overhauling load.

Alignment

Requirements per NEMA:

Permissible ECCENTRICITY of mounting rabbet (AK dimension):

42C to 286TC frames inclusive is 0.004" total indicator reading. 324TC to 505TC frames inclusive is 0.007" total indicator reading.

Face Runout:

42C to 286TC frames inclusive is 0.004" total indicator reading.

If a customer furnishes a face on the machine for brake mounting, the same tolerances apply. Floor mounted brakes must be carefully aligned within 0.005" for concentricity and angular alignment. Use of dowels to insure permanent alignment is recommended.

In offset brake mount locations such as fan covers, cowls or jack shafting, proper mount rigidity and bearing support must be provided. Spring set frictional brakes characteristically have a rapid stop during torque application which may affect the mount surface or contribute to shaft deflection.

Printed installation information is published and available on all Stearns spring set brakes.

Determining Brake Torque

Torque Ratings

Brake torque ratings are normally expressed as nominal static torque. That is, the torque required to begin rotation of the brake from a static, engaged condition. This value is to be distinguished from dynamic torque, which is the retarding torque required to stop a linear, rotating or overhauling load.

As a general rule, a brake's dynamic torque is approximately 80% of the static torque rating of the brake for stopping time up to one second. Longer stopping time will produce additional brake heat and possible fading (reduction) of dynamic torque. The required dynamic torque must be converted to a static torque value before selecting a brake, using the relationship:

$$T_s = \frac{T_d}{0.8}$$

Where, T_s = Static torque, lb-ft

T_d = Dynamic torque, lb-ft

0.8 = Constant
(derating factor)

All Stearns brakes are factory burnished and adjusted to produce no less than rated nominal static torque. Burnishing is the initial wear-in and mating of the rotating friction discs with the stationary metallic friction surfaces of the brake.

Although brakes are factory burnished and adjusted, variations in torque may occur if components are mixed when disassembling and reassembling the brake during installation. Further burnishing may be necessary after installation. Friction material will burnish under normal load conditions. Brakes used as holding only duty require friction material burnishing at or before installation to insure adequate torque.

When friction discs are replaced, the brake must be burnished again in order to produce its rated holding torque.

System Friction

The friction and rolling resistance in a power transmission system is usually neglected when selecting a brake. With the use of anti-friction bearings in the system, friction and rolling resistance is usually low enough to neglect. Friction within the system will assist the brake in stopping the load. If it is desired to consider it, subtract the frictional torque from the braking torque necessary to decelerate and stop the load. Friction and rolling resistance are neglected in the examples presented in this guide.

Non-overhauling Loads

There are two methods for determining brake torque for non-overhauling loads. The first method is to size the brake to the torque of the motor. The second is to select a brake on the basis of the total system or load inertia to be stopped.

Selecting Brake Torque from the Motor Data

Motor full-load torque based on nameplate horsepower and speed can be used to select a brake. This is the most common method of selecting a brake torque rating due to its simplicity.

This method is normally used for simple rotary and linear inertial loads. Brake torque is usually expressed as a percent of the full load torque of

the motor. Generally this figure is not less than 100% of the motor's full load torque. Often a larger service factor is considered. Refer to Selection of Service Factor.

The required brake torque may be calculated from the formula:

$$T_s = \frac{5,252 \times P}{N} \times SF$$

Where, T_s = Static brake torque, lb-ft

P = Motor horsepower, hp

N = Motor full load speed, rpm

SF = Service factor

5,252 = Constant

Match the brake torque to the hp used in the application. When an oversized motor hp has been selected, brake torque based on the motor hp may be excessive for the actual end use.

Nameplate torque represents a nominal static torque. Torque will vary based on combinations of factors including cycle rate, environment, wear, disc burnish and flatness. Spring set brakes provide a rapid stop and hold and are generally not used in repeat positioning applications.

Selection of Service Factor (SF)

A service factor is applied to the basic drive torque calculation. The SF compensates for any tolerance variation, data inaccuracy, unplanned transient torque and potential variations of the friction disc.

When using the basic equation:

$T = (\text{hp} \times 5252) / \text{rpm}$ with non-overhauling loads, a service factor of 1.2 to 1.4 is typical. Overhauling loads with unknown factors such as reductions may use a service factor of 1.4 to 1.8.

Spring set brakes combined with variable frequency drives use service factors ranging from 1.0 to 2.0 (2.0 for holding duty only) depending on the system design. These holding duty brakes must be wired to a separate dedicated power supply.

Occasionally, a brake with a torque rating less than the motor full load torque or with a service factor less than 1.0 is selected. These holding or soft stop applications must be evaluated by the end user or system designer to insure adequate sizing and thermal capacity.

Typically a brake rated 125% of the motor full load torque, or with a 1.25 service factor, provides a stop in approximately the same time as that required for the motor to accelerate the load to full load speed.

Occasionally a motor is oversized or undersized for the load or application. In these situations, the load inertia and desired stopping time calculations should be used rather than relying on the service factor method alone.

Service factor selection can be based on motor performance curves. Motor rotor and load inertia should be considered in this selection process. Depending on the motor design (NEMA A, B, C and D), rpm and horsepower, the maximum torque is either the starting or breakdown torque. A NEMA design B, 3 phase, squirrel cage design motor at breakdown torque produces a minimum of 250% the full load torque. A service factor of 2.5 would be selected. Typical service factors depending on NEMA motor design are: NEMA design A or B: 1.75 to 3.0, NEMA design C: 1.75 to 3.0 and NEMA design D: not less than 2.75.

A brake with an excessive service factor may result in system component damage, an unreasonably rapid stop or loss of load control. A SF above 2.0 is not recommended without evaluation by the end user or system designer.

Example 1: Select brake torque from motor horsepower and speed.

Given: Motor power (P) - 5 hp

Motor speed (N) - 1,750 rpm

Service factor (SF) - 1.4

$$T = \frac{5,252 \times P}{N} \times SF$$

$$= \frac{5,252 \times 5}{1,750} \times 1.4$$

$$T = 21 \text{ lb-ft}$$

A brake having a standard rating of 25 lb-ft nominal static torque would be selected.

Example 2 illustrates selection of a brake to provide proper static torque to hold a load if dynamic braking were used to stop the load.

Example 2: Select a brake to hold a load in position after some other method, such as dynamic braking of the motor, has stopped all rotation.

Given: Weight of load (W) - 5 lb

Drum radius (R) - 2 ft

Service factor (SF) - 1.4

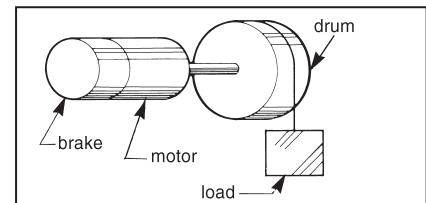

The static holding torque is determined by the weight of the load applied at the drum radius. A service factor is applied to ensure sufficient holding torque is available in the brake.

$$T_s = F \times R \times SF$$

$$= 5 \times 2 \times 1.4$$

$$T_s = 14 \text{ lb-ft}$$

Sizing the Brake to the Inertial Load

For applications where the load data is known, where high inertial loads exist, or where a stop in a specified time or distance is required, the brake should be selected on the basis of the total inertia to be retarded. The total system inertia, reflected to the brake shaft speed, would be:

$$Wk_T^2 = Wk_B^2 + Wk_M^2 + Wk_L^2$$

Where: Wk_T^2 = Total inertia reflected to the brake, lb-ft²

Wk_B^2 = Inertia of brake, lb-ft²

Wk_M^2 = Inertia of motor rotor, lb-ft²

Wk_L^2 = Equivalent inertia of load reflected to brake shaft, lb-ft²

Other significant system inertias, including speed reducers, shafting, pulleys and drums, should also be considered in determining the total inertia the brake would stop.

If any component in the system has a rotational speed different than the rotational speed of the brake, or any linear moving loads are present, such as a conveyor load, their equivalent inertia in terms of rotary inertia at the brake rotational speed must be determined. The following formulas are applicable:

Rotary Motion:

$$\text{Equivalent } Wk_B^2 = Wk_L^2 \left(\frac{N_L}{N_B} \right)^2$$

Where,

Equivalent Wk_B^2 = Inertia of rotating load reflected to brake shaft, lb-ft²

Wk_L^2 = Inertia of rotating load, lb-ft²

N_L = Shaft speed at load, rpm

N_B = Shaft speed at brake, rpm

Horizontal Linear Motion

$$\text{Equivalent } Wk_W^2 = W \left(\frac{V}{2\pi N_B} \right)^2$$

Where,

Equivalent Wk_W^2 = Equivalent inertia of linear moving load reflected to brake shaft, lb-ft²

W = Weight of linear moving load, lb

V = Linear velocity of load, ft/min

N_B = Shaft speed at brake, rpm

Once the total system inertia is calculated, the required average dynamic braking torque can be calculated using the formula:

$$T_d = \frac{Wk_T^2 \times N_B}{308 \times t}$$

Where, T_d = Average dynamic braking torque, lb-ft

Wk_T^2 = Total inertia reflected to brake, lb-ft²

N_B = Shaft speed at brake, rpm

t = Desired stopping time, sec

308 = Constant

The calculated dynamic torque is converted to the static torque rating using the relationship:

$$T_s = \frac{T_d}{0.8}$$

Where, T_s = Brake static torque, lb-ft

T_d = System dynamic torque, lb-ft

Examples 3, 4, 5 and 6 illustrate how brake torque is determined for non-overhauling loads where rotary or horizontal linear motion is to be stopped.

Example 3: Select a brake to stop a rotating flywheel in a specified time.

Given, Motor speed (N_M) - 1,750 rpm

Motor inertia (Wk_M^2) - 0.075 lb-ft²

Flywheel inertia (Wk_{FW}^2) - 4 lb-ft²

Brake inertia (Wk_B^2) - 0.042 lb-ft²

Required stopping time (t) - 1 sec

First determine the total inertia to be stopped,

$$Wk_T^2 = Wk_M^2 + Wk_{FW}^2 + Wk_B^2$$

$$= 0.075 + 4 + 0.042$$

$$Wk_T^2 = 4.117 \text{ lb-ft}^2$$

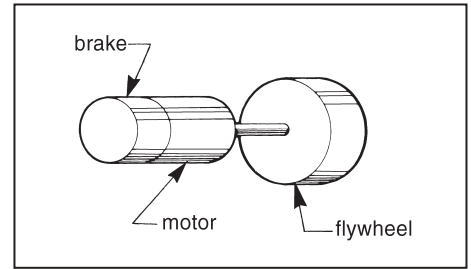

The dynamic braking torque required to stop the total inertia in 1 second is,

$$T_d = \frac{Wk_T^2 \times N_{BM}}{308 \times t}$$

$$= \frac{4.117 \times 1,750}{308 \times 1}$$

$$T_d = 23.4 \text{ lb-ft}$$

Converting T_d to static torque

$$T_s = \frac{T_d}{0.8}$$

$$= \frac{23.4}{0.8}$$

$$T_s = 29.3 \text{ lb-ft}$$

A brake having a standard static torque rating of 35 lb-ft would be selected. Since a brake with more torque than necessary to stop the flywheel in 1 second is selected, the stopping time would be,

$$t = \frac{Wk_T^2 \times N_{BM}}{308 \times T_d}$$

$$= \frac{Wk_T^2 \times N_{BM}}{308 \times (0.8 T_s)}$$

$$= \frac{4.117 \times 1,750}{308 \times (0.8 \times 35)}$$

$$t = 0.84 \text{ sec}$$

See section on stopping time and thermal information.

Example 4: Select a brake to stop a rotating flywheel, driven through a gear reducer, in a specified time.

Given: Motor speed (N_M) - 1,800 rpm

Motor inertia (Wk_M^2) - 0.075 lb-ft²

Gear reduction (GR) - 20:1

Gear reducer inertia at high speed shaft (Wk_{GR}^2) - 0.025 lb-ft²

Flywheel inertia (Wk_{FW}^2) - 20 lb-ft²

Required stopping time (t) - 0.25 sec

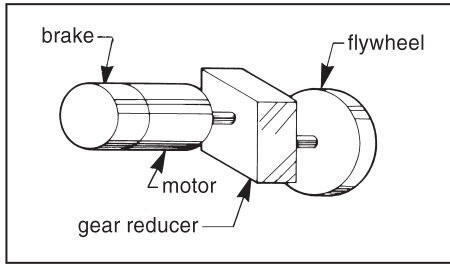

First, determine rotating speed of flywheel (N_{FW})

$$N_{FW} = \frac{N_{BM}}{GR}$$

$$= \frac{1,800}{20}$$

$$N_{FW} = 90 \text{ rpm}$$

Next, the inertia of the flywheel must be reflected back to the motor brake shaft.

$$Wk_b^2 = Wk_{FW}^2 \left(\frac{N_{FW}}{N_M} \right)^2$$

$$= 20 \left(\frac{90}{1,800} \right)^2$$

$$Wk_b^2 = 0.05 \text{ lb-ft}^2$$

Determining the total Wk^2 ,

$$Wk_T^2 = Wk_M^2 + Wk_{GR}^2 + Wk_b^2$$

$$= 0.075 + 0.025 + 0.05$$

$$Wk_T^2 = 0.15 \text{ lb-ft}^2$$

The required dynamic torque to stop the flywheel in 0.25 seconds can now be determined.

$$T_d = \frac{Wk_T^2 \times N_{BM}}{308 \times t}$$

$$T_d = \frac{0.15 \times 1,800}{308 \times 0.25}$$

$$T_d = 3.5 \text{ lb-ft}$$

Converting dynamic torque to static torque,

$$T_s = \frac{T_d}{0.8}$$

$$= \frac{3.5}{0.8}$$

$$T_s = 4.4 \text{ lb-ft}$$

A brake having a standard static torque rating of 6 lb-ft would be selected. Since a brake with more torque than necessary to stop the flywheel in 0.25 seconds is selected, the stopping time would be,

$$t = \frac{Wk_T^2 \times N_M}{308 \times T_d}$$

$$= \frac{Wk_T^2 \times N_M}{308 \times (0.8 \times T_s)}$$

$$= \frac{0.15 \times 1,800}{308 \times (0.8 \times 6)}$$

$$t = 0.18 \text{ sec}$$

See section on stopping time and thermal information.

Example 5: Select a brake to stop a load on a horizontal belt conveyor in a specified time.

Given:

Conveyor pulley speed (N_p) - 32 rpm

Weight of load (W) - 30 lb

Conveyor pulley and belt inertia (Wk_p^2) - 4.0 lb-ft²

Conveyor pulley diameter (d_p) - 1 ft

Required stopping time (t) - 0.25 sec

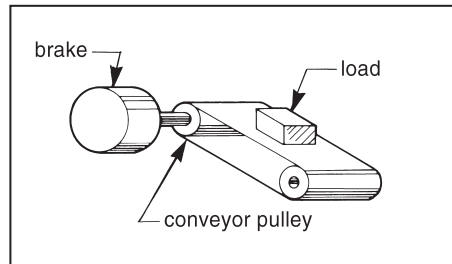

First, convert the rotational pulley speed to linear belt speed (V_B).

$$V_B = \pi d_p N_p$$

$$= \pi \times 1 \times 32$$

$$V_B = 100.5 \text{ ft/min}$$

Next, determine inertia of load.

$$Wk_W^2 = W \left(\frac{V_B}{2\pi \times N_p} \right)^2$$

$$= 30 \left(\frac{100.5}{2\pi \times 32} \right)^2$$

$$Wk_W^2 = 7.5 \text{ ft-lb}^2$$

Then, determine total inertial load.

$$Wk_T^2 = Wk_W^2 + Wk_p^2$$

$$= 7.5 + 4.0$$

$$Wk_T^2 = 11.5 \text{ lb-ft}^2$$

The required dynamic torque to stop the conveyor load in 0.25 seconds can now be determined.

$$T_d = \frac{Wk_T^2 \times N_p}{308 \times t}$$

$$T_d = \frac{11.5 \times 32}{308 \times 0.25}$$

$$T_d = 4.8 \text{ lb-ft}$$

Converting dynamic torque to static torque,

$$T_s = \frac{T_d}{0.8}$$

$$= \frac{4.8}{0.8}$$

$$T_s = 6 \text{ lb-ft}$$

A brake having a standard static torque rating of 6 lb-ft would be selected. See thermal information.

Example 6: Select a brake to stop a trolley crane and its load in a specified time. Brake mounted on wheel axle.

Given:

Weight of crane (W_c) - 2,000 lb

Weight of load (W_L) - 100 lb

Trolley velocity (v) - 3 ft/sec or 180 ft/min

Radius of trolley wheel (r) - 0.75 ft

Required stopping time (t) - 2 sec

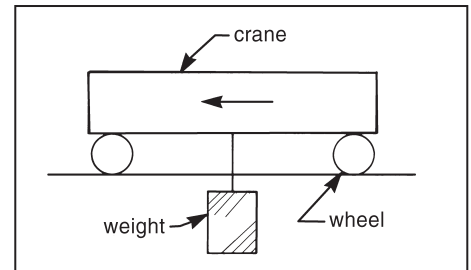

The dynamic braking torque required to stop the trolley crane and load can be determined by one of two methods. The first method is to determine the equivalent inertia of the linearly moving crane and load, then calculate the dynamic braking torque. The second method is to determine the dynamic braking torque directly.

Using the first method, the total weight to be stopped is determined first.

$$W_T = W_L + W_C$$

$$= 100 + 2,000$$

$$W_T = 2,100 \text{ lb}$$

Next, the rotational speed of the axle (N_B) is calculated.

$$N_B = \frac{V}{2\pi r}$$

$$= \frac{180}{2 \times \pi \times 0.75}$$

$$N_B = 38.2 \text{ rpm}$$

Then, the equivalent inertia of the linearly moving crane and load is determined.

$$Wk_f^2 = W_T \left(\frac{V}{2\pi N_B} \right)^2$$

$$= 2,100 \left(\frac{180}{2\pi \times 38.2} \right)^2$$

$$Wk_f^2 = 1,181 \text{ lb-ft}^2$$

Finally, the dynamic braking torque required to stop the total inertia in 2 seconds is,

$$T_d = \frac{Wk_f^2 \times N_B}{308 \times t}$$

$$= \frac{1,181 \times 38.2}{308 \times 2}$$

$$T_d = 73 \text{ lb-ft}$$

Using the second method, the dynamic braking torque required to stop the crane and load in 2 seconds can be calculated directly using the formula,

$$T_d = \frac{W_T v}{gt} \times r$$

Where, T_d = Average dynamic braking torque, lb-ft

W_T = Total weight of linear moving load, lb

v = Linear velocity of load, ft/sec

g = Gravitational acceleration constant, 32.2 ft/sec²

t = Desired stopping time, sec

r = Length of the moment arm (wheel radius), ft

or, for this example,

$$T_d = \frac{2,100 \times 3}{32.2 \times 2} \times 0.75$$

$$T_d = 73 \text{ lb-ft}$$

For both methods above, the required dynamic braking torque is converted to static torque,

$$T_s = \frac{T_d}{0.8}$$

$$= \frac{73}{0.8}$$

$$T_s = 91 \text{ lb-ft}$$

A smaller brake could be mounted on the high speed shaft in place of the higher torque on the low speed shaft.

A brake having a standard static torque rating of 105 lb-ft is selected. Since a brake with more torque than necessary to stop the load in 2 seconds is selected, the stopping time would be,

$$T = \frac{W_T v}{g T_d} \times r$$

$$= \frac{W_T v}{g \times (0.8 \times T_s)} \times r$$

$$= \frac{2,100 \times 3}{32.2 \times (0.8 \times 105)} \times 0.75$$

$$t = 1.8 \text{ sec}$$

See section on stopping time and cycle rates, thermal selection. Stops should be under 2 seconds. Longer stops require application test.

Overhauling Loads

Applications with a descending load, such as power lowered crane, hoist or elevator loads, require a brake with sufficient torque to both *stop* the load, and *hold* it at rest. Overhauling loads having been brought to rest still invite motion of the load due to the effect of gravity. Therefore, brake torque must be larger than the overhauling torque in order to stop and hold the load. If brake torque is equal to or less than the overhauling torque, there is no net torque available for stopping a descending load.

First, the total system inertia reflected to the brake shaft speed must be calculated.

Second, the average dynamic torque required to decelerate the descending load in the required time is calculated with the formula:

$$T_d = \frac{Wk_f^2 \times N_B}{308 \times t}$$

Where, T_d = Average dynamic braking torque, lb-ft

Wk_f^2 = Total inertia reflected to brake, lb-ft²

N_B = Shaft speed at brake, rpm. Consider motor slip when descending.

t = Desired stopping time, sec

Third, the overhauling torque reflected to the brake shaft is determined by the formula:

$$T_o = W \times R \times \frac{N_L}{N_B}$$

Where, T_o = Overhauling dynamic torque of load reflected to brake shaft, lb-ft

W = Weight of overhauling load, lb

R = Radius of hoist or elevator drum, ft

N_L = Rotating speed of drum, rpm

N_B = Rotating speed at brake, rpm

Or alternately, the dynamic torque to overcome the overhauling load can be calculated with the formula:

$$T_o = \frac{0.158 \times W \times V}{N_B}$$

Where, T_o = Overhauling dynamic torque of load reflected to brake shaft, lb-ft

W = Weight of overhauling load, lb

V = Linear velocity of descending load, ft/min

N_B = Shaft speed at brake, rpm

0.158 = Constant

Next, the total dynamic torque required to stop and hold the overhauling load is the sum of the two calculated dynamic torques:

$$T_t = T_d + T_o$$

Finally, the dynamic torque must be converted to static brake torque to select a brake:

$$T_s = \frac{T_d}{0.8}$$

Where, T_s = Brake static torque, lb-ft

T_t = System dynamic torque, lb-ft

If the total inertia of the system and overhauling load cannot be accurately determined, a brake rated at 180% the motor full load torque should be selected. Refer to selection of service factor. The motor starting torque may permit a heavier than rated load to be lifted; the brake must stop the load when descending.

Examples 7, 8 and 9 illustrate how brake torque would be determined for overhauling loads. In these examples brakes are selected using the system data rather than sizing them to the motor. Refer to the section on thermal calculations to determine cycle rate.

Consider motor slip in calculation. An 1800 rpm motor with 10% slip would operate at 1,620 rpm when the load is ascending and 1,980 rpm when descending. Motor rpm, armature inertia and load position will affect stop time. Brakes on overhauling loads should be wired through a dedicated relay.

Example 7: Select a brake to stop an overhauling load in a specified time.

Given: Cable speed (V) - 667 ft/min
 Weight of load (W) - 100 lb
 Drum diameter (D) - 0.25 ft
 Drum inertia (Wk_d^2) - 5 lb-ft²
 Required stopping time (t) - 1 sec

First, determine brakemotor shaft speed (N_B).

$$N_B = \frac{V}{\pi D}$$

$$= \frac{667}{\pi \times 0.25}$$

$$N_B = 849 \text{ rpm}$$

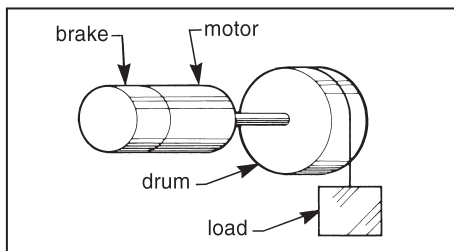

Then, determine the equivalent inertia of the overhauling load.

$$Wk_f^2 = W \left(\frac{V}{2\pi N_B} \right)^2$$

$$= 100 \left(\frac{667}{2\pi \times 849} \right)^2$$

$$Wk_f^2 = 1.56 \text{ lb-ft}^2$$

Therefore, the total inertia at the brake is,

$$Wk_f^2 = Wk_d^2 + Wk_f^2$$

$$= 5 + 1.56$$

$$Wk_f^2 = 6.56 \text{ lb-ft}^2$$

Now, the dynamic torque required to decelerate the load and drum in the required time is calculated.

$$T_d = Wk_f^2 \times N_B$$

$$= \frac{6.56 \times 850}{308 \times 1}$$

$$T_d = 18.1 \text{ lb-ft}$$

Next, calculate the dynamic torque required to overcome the overhauling load.

$$T_o = W \times R$$

$$= 100 \times \frac{0.25}{2}$$

$$T_o = 12.5 \text{ lb-ft}$$

The total dynamic torque to stop and hold the overhauling load is the sum of the two calculated dynamic torques.

$$T_t = T_d + T_o$$

$$= 18.1 + 12.5$$

$$T_t = 30.6 \text{ lb-ft}$$

Dynamic torque is then converted to static torque.

$$T_s = \frac{T_t}{0.8}$$

$$= \frac{30.6}{0.8}$$

$$T_s = 38.3 \text{ lb-ft}$$

A brake having a standard torque rating of 50 lb-ft is selected based on expected stop time. Since a brake with more torque than necessary to stop the load in 1 second is selected, the stopping time would be,

$$t = \frac{Wk_f^2 \times N}{308 \times T_d}$$

where,

$$T_s = \frac{T_t}{0.8}$$

$$= \frac{T_d + T_o}{0.8}$$

or,

$$T_d = 0.8T_s - T_o$$

$$= (0.8)(50) - 12.5$$

$$T_d = 27.5 \text{ lb-ft}$$

therefore,

$$t = \frac{6.56 \times 850}{308 \times 27.5}$$

$$t = 0.7 \text{ sec}$$

Wire the brake through a dedicated relay on overhauling loads where stop time or distance is critical. See section on stopping time.

Example 8: Select a brake to stop an overhauling load driven through gear reducer in a specified time.

Given: Motor speed (N_M) - 1,150 rpm
 Motor inertia (Wk_M^2) - 0.65 lb-ft²
 Gear reduction (GR) - 300:1
 Drum diameter (D) - 1.58 ft
 Weight of load (W) - 4,940 lb
 Drum inertia (Wk_d^2) - 600 lb-ft²
 Required stopping time (t) - 0.5 sec

First, calculate all inertial loads reflected to the brake motor shaft.

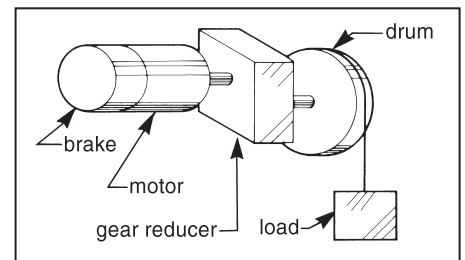

The rotational speed of the drum is,

$$N_D = \frac{N_M}{GR}$$

$$= \frac{1,150}{300}$$

$$N_D = 3.83 \text{ rpm}$$

From this, the cable speed can be determined.

$$V = N_D \times \pi D$$

$$= 3.83 \times \pi \times 1.58$$

$$V = 19.0 \text{ ft/min}$$

The equivalent inertia of the load reflected to the brake motor shaft is,

$$Wk_f^2 = W \left(\frac{V}{2\pi N_{BM}} \right)^2$$

$$= 4,940 \left(\frac{19.0}{2\pi \times 1,150} \right)^2$$

$$Wk_f^2 = 0.034 \text{ lb-ft}^2$$

The equivalent inertia of the drum at the brake motor shaft speed is,

$$Wk_d^2 = Wk_D^2 \left(\frac{N_D}{N_{BM}} \right)^2$$

$$= 600 \left(\frac{3.83}{1,150} \right)^2$$

Finally, the total inertia the brake will retard is,

$$Wk_t^2 = Wk_m^2 + Wk_f^2 + Wk_d^2$$

$$Wk_t^2 = 0.0067 \text{ lb-ft}^2$$

$$Wk_t^2 = 0.691 \text{ lb-ft}^2$$

The dynamic torque required to decelerate the total inertia is,

$$T_d = \frac{Wk_t^2 \times N_{BM}}{308 \times t}$$

$$= \frac{0.691 \times 1,150}{308 \times 0.5}$$

$$T_d = 5.16 \text{ lb-ft}^2$$

Now, calculate the dynamic torque to overcome the overhauling load.

$$T_o = W \times R = W \times \frac{1}{2} D$$

$$= 4,940 \times \frac{1.58}{2}$$

$$T_o = 3,903 \text{ lb-ft}$$

Which reflected to the brake motor shaft becomes,

$$T_m = \frac{T_o}{GR}$$

$$= \frac{3,903}{300}$$

$$T_m = 13.0 \text{ lb-ft}$$

Then, the total dynamic torque to stop and hold the overhauling load is the sum of the two calculated dynamic torques.

$$T_t = T_d + T_m$$

$$= 5.16 + 13.0$$

$$T_t = 18.16 \text{ lb-ft}$$

Dynamic torque is then converted to static torque.

$$T_s = \frac{T_t}{0.8}$$

$$= \frac{18.16}{0.8}$$

$$T_s = 22.7 \text{ lb-ft}$$

A brake having a standard torque rating of 25 lb-ft is selected.

Example 9: Select a brake to stop and hold a load on an inclined plane (skip hoist).

Given: Motor data
Power (P) - 7½ hp
Speed (N_M) - 1,165 rpm
Rotor inertia (Wk_M²) - 1.4 lb-ft²

Gear reducer data:

Reduction (G_R) - 110:1
Inertia at input shaft (Wk_R²) - 0.2 lb-ft²

Drum data

Diameter (D_D) - 1.5 ft
Inertia (Wk_D²) - 75 lb-ft²

Pulley data

Diameter (D_P) - 1.5 ft
Inertia (Wk_P²) - 20 lb-ft²
Bucket weight (W_B) - 700 lb
Maximum weight of load (W_L) - 4,000 lb
Slope of track (B) - 52.7°

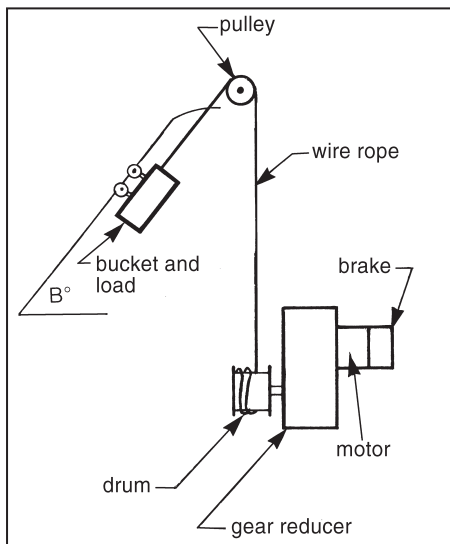

Required stopping time (t) - 1 sec

The bucket is full when ascending the track and is empty when descending. When selecting a brake the most severe condition would be a fully loaded bucket backed down the hoist track. In normal operation the descending bucket would be empty. In this example, the brake is selected for the most severe condition.

The total torque to stop and hold the bucket and load when descending is the sum of (a) the torque to decelerate the total inertia and (b) the torque required to hold the loaded bucket.

First, calculate all inertial loads reflected to the brake motor shaft. The rotational speed of the drum is:

$$N_D = \frac{N_M}{GR}$$

$$= \frac{1,165}{110}$$

$$N_D = 10.6 \text{ rpm}$$

From this the cable speed can be determined:

$$V = N_D \times \pi D_D$$

$$= 10.6 \times \pi \times 1.5$$

$$V = 50 \text{ ft/min}$$

The equivalent inertia of the loaded bucket reflected to the brake motor shaft is,

$$Wk_f^2 = W \left(\frac{V}{2\pi N_M} \right)^2$$

$$= 4,700 \left(\frac{50}{2\pi \times 1,165} \right)^2$$

$$Wk_f^2 = 0.219 \text{ lb-ft}^2$$

Next, the inertia of the pulley and drum are reflected to the brake motor shaft speed so the total inertia at the brake can be determined.

Since the diameters of the pulley and drum are the same, 1.5 ft, their rotational speeds would be the same, 10.6 rpm.

The inertia of the pulley reflected to the brake motor shaft is,

$$Wk_p^2 = Wk_P^2 \left(\frac{N_D}{N_M} \right)^2 = Wk_P^2 \left(\frac{1}{GR} \right)^2$$

$$= 20 \times \left(\frac{1}{110} \right)^2$$

$$Wk_p^2 = 0.0017 \text{ lb-ft}^2$$

The inertia of the drum reflected to the brake motor shaft is,

$$Wk_d^2 = Wk_D^2 \left(\frac{N_D}{N_M} \right)^2 = Wk_D^2 \left(\frac{1}{GR} \right)^2$$

$$= 75 \times \left(\frac{1}{110} \right)^2$$

$$Wk_d^2 = 0.0062 \text{ lb-ft}^2$$

The total inertia to be stopped is,

$$Wk_t^2 = Wk_f^2 + Wk_p^2 + Wk_d^2 + Wk_R^2 + Wk_M^2$$

$$= 0.219 + 0.0017 + 0.0062 + 0.2 + 1.4$$

$$Wk_t^2 = 1.827 \text{ lb-ft}^2$$

Then, the dynamic torque required to bring the descending bucket and load to rest is,

$$T_d = \frac{Wk_t^2 \times N_M}{308 \times T_d}$$

$$T_d = \frac{1.827 \times 1,165}{308 \times 1}$$

The additional dynamic torque required to hold the overhauling load would be determined by the unbalanced component of the force acting along the plane of the hoist track, $W_T \sin B$, and the length of the moment arm which is the drum radius (R_D). $W_T \sin B$ is the force necessary to retard downward motion of the loaded hoist bucket.

$$\begin{aligned} T_O &= W_T \sin B \times R_D \\ &= W_T \sin B \times \frac{1}{2} D_D \\ &= 4,700 \times \sin 52.7^\circ \times \frac{1}{2} (1.5) \\ &= 4,700 \times 0.7955 \times 0.75 \\ T_O &= 2,804 \text{ lb-ft} \end{aligned}$$

Which reflected to the brake motor shaft becomes,

$$\begin{aligned} T_m &= \frac{T_O}{GR} \\ &= \frac{2,804}{110} \\ T_m &= 25.5 \text{ lb-ft} \end{aligned}$$

Then, the total dynamic torque to stop and hold the descending bucket and load is the sum of the two calculated dynamic torques.

$$\begin{aligned} T_t &= T_d + T_m \\ &= 6.9 + 25.5 \\ T_t &= 32.4 \text{ lb-ft} \end{aligned}$$

Converting to static torque,

$$\begin{aligned} T_s &= \frac{T_t}{0.8} \\ &= \frac{32.4}{0.8} \\ T_s &= 40.5 \text{ lb-ft} \end{aligned}$$

A brake having a standard torque rating of 50 lb-ft is selected. Since a brake with more torque than necessary to stop the load in 1 second is selected, the stopping time would be,

$$t = \frac{Wk_f^2 \times N_B}{308 \times T_d}$$

$$\begin{aligned} \text{Where, } T_s &= \frac{T_t}{0.8} \\ &= \frac{T_d + T_m}{0.8} \end{aligned}$$

$$\begin{aligned} \text{or, } T_d &= 0.8 T_s - T_m \\ &= (0.8)(50) - 25.5 \end{aligned}$$

$$T_d = 14.5 \text{ lb-ft}$$

therefore,

$$\begin{aligned} t &= \frac{1,827 \times 1,165}{308 \times 14.5} \\ t &= 0.48 \text{ sec} \end{aligned}$$

See section on stopping time.

Stopping Time & Deceleration Rate

In the formulas used to determine dynamic torque, stopping time or "t" in seconds is a desired or assumed value selected on the requirements of the application. For optimum brake performance, a stopping or braking time of 1 second or less is desirable. Stop times between 2 and 3 seconds require test. *A brake of insufficient torque rating will lengthen the stopping time. This may result in overheating of the brake to a point where torque falls appreciably. The friction material could carbonize, glaze, or fail.*

After determining the braking torque required by a system, it may be necessary to recalculate the stopping time based on the actual brake size selected to insure that stopping time falls within the 0 to 2 second range. Any formula, where the stopping time is a variable, may be rewritten to solve for the new stopping time. For instance, the dynamic torque equation may be transposed as follows:

$$\begin{aligned} T_d &= \frac{Wk_f^2 \times N_B}{308 \times t} \\ \text{or, } t &= \frac{Wk_f^2 \times N_B}{308 \times (0.8 \times T_s)} \end{aligned}$$

Where, t = Stopping time, sec

Wk_f^2 = Total inertia reflected to brake, lb-ft²

N_B = Shaft speed at brake, rpm

T_s = Nominal static torque rating of brake, lb-ft

T_d = Dynamic braking torque (0.8 x T_s), lb-ft

0.8 = Constant (derating factor)

308 = Constant

Brakes are rated in static torque. This value is converted to dynamic torque, as done in the above equation, when stopping time is calculated. That is,

$$T_d = 0.8 \times T_s$$

Where, T_d = Dynamic braking torque, lb-ft

T_s = Nominal static torque rating of brake, lb-ft

The approximate number of revolutions the brake shaft makes when stopping is:

$$\text{Revolutions to stop} = \frac{t \times N_B}{120}$$

Where, t = Stopping time, sec

N_B = Shaft speed at brake, rpm

120 = Constant

The average rate of deceleration when braking a linearly moving load to rest can be calculated using the stopping time determined by the above formula and the initial linear velocity of the load.

$$a = \frac{V_i}{t}$$

Where, a = Deceleration, ft/sec²

V_i = Initial linear velocity of load, ft/sec

t = Stopping time, sec

RPM Considerations

The maximum allowable rotational speed of the brake should not be exceeded in braking. Maximum brake rpm as listed in the catalog is intended to limit stopping time to 2 seconds or less and insure friction disc stability. Brakes are not dynamically balanced because of the low brake inertia.

Determining Required Thermal Capacity

Thermal Ratings

When a brake stops a load, it converts mechanical energy to thermal energy or heat. The heat is absorbed by components of the brake. This heat is then dissipated by the brake. The ability of a given brake to absorb and dissipate heat without exceeding temperature limitations is known as thermal capacity.

There are two categories of thermal capacity for a brake. The first is the *maximum* energy the brake can absorb in one stop, generally referred to as a "crash" or "emergency" stop. The second is the heat dissipation capability of the brake when it is cycled frequently. *To achieve optimum brake performance, the thermal rating should not be exceeded. They are specified for a predetermined maximum temperature rise of the brake friction material.*

The ability of a brake to absorb and dissipate heat is determined by many factors, including the design of the brake, the ambient temperature, brake enclosure, position of the brake, the surface that the brake is mounted to, and the altitude.

The rating for a given brake is the maximum allowable. Longer brake life results when the brake has more thermal capacity than a power transmission requires. Much shorter life or brake failure will result when the thermal capacity rating is exceeded. Ratings are determined at an ambient temperature of 72°F (22°C), with the brake in a horizontal position, with a stopping time of 1 second or less, and with no external heat source such as a motor.

Ambient temperature will limit the thermal capacity of a brake. Temperatures above 72°F (22°C) require derating of the thermal capacity rating. For example, at 150°F, thermal capacity is reduced approximately 30% (see Derating Thermal Capacity Chart).

CHART: Derating Thermal Capacity

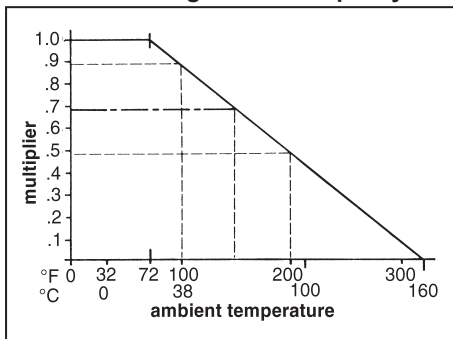

A temperature range of 20°F (-7°C) to 104°F (40°C) is acceptable in most brake applications. Above 104°F also consider Class H coil insulation.

Thermal capacity ratings are determined with enclosures on the brake. Other customer furnished covers or cowls may affect a brake's thermal capacity. The effect on thermal capacity should be evaluated. In some cases, thermal capacity may be increased by use of air or liquid cooling. However, provisions must be made to prevent contaminating the brake internally.

Brakes with brass stationary discs are derated 25%.

The mounting position of a brake will also affect thermal capacity. The specified ratings are for brakes mounted in a horizontal position with the solenoid plunger above the solenoid. For brakes mounted in a vertical position, or 15° or more from horizontal, the thermal capacity decreases due to friction disc drag. Brakes are modified for vertical operation to minimize the drag. 2- and 3- disc brakes are derated 25%, 4-disc brakes are derated 33%. 4- and 5-disc brakes are not recommended for vertical use.

Thermal capacity ratings are established without external sources of heat increasing the brake temperature. The surface that a brake is mounted to, such as an electric

motor or gear reducer, will limit the heat dissipation capability or thermal capacity of a brake. These sources of heat should be evaluated when determining the thermal requirements of the system for which the brake is selected.

High altitudes may also affect a brake's thermal capacity. Stearns brakes will operate to 10,000 ft above sea level at 72°F (22°C) ambient temperature. At 104°F (40°C) ambient temperature, altitude and temperature adjustments occur. Refer to NEMA MG1-1993 section 14 for additional information.

CHART: Altitude & Thermal Capacity

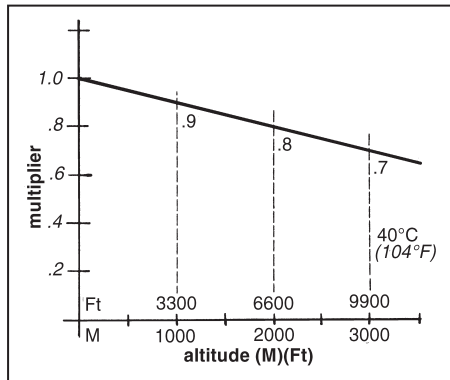

Maximum Energy Absorption

The thermal capacity of a brake is limited by the maximum energy it can absorb in one stop. This factor is important when stopping extremely high inertial loads at infrequent intervals. Such use of a brake requires extensive cooling time before it can be operated again.

The energy a brake is required to absorb in one stop by a given power transmission system is determined by the formulas below. *The calculated energy of the system should not exceed the maximum kinetic energy rating of the brake. System energy exceeding the brake's maximum rating may result in overheating of the brake to a point where torque falls appreciably. The friction material of the brake could glaze, carbonize or fail.*

In the case of linear loads, the energy that the brake must absorb is kinetic energy. It is determined by the formula:

$$KE_l = \frac{Wv^2}{2g}$$

KE_l = Kinetic energy of linear moving load, lb-ft

W = Weight of load, lb

v = Linear velocity of load, ft/sec

g = Gravitational acceleration constant, 32.2 ft/sec²

In the case of rotational loads, the energy that the brake must absorb is also kinetic energy. It is determined by the formula:

$$KE_r = \frac{Wk_f^2 \times N_B^2}{5875}$$

Where, KE_r = Kinetic energy of linear load, lb-ft

Wk_f² = Inertia of the rotating load reflected to brake shaft, lb-ft²

N_B = Shaft speed at brake, rpm

5875 = Constant

In the case of overhauling loads, both the kinetic energy of the linear and rotating loads and the potential energy transformed into kinetic energy by the change in height or position must be considered when determining the total energy that the brake must absorb. The potential energy transformed to kinetic energy is determined by the formula:

$$PE = W_s$$

Where, PE = Change in potential energy, ft-lb

W = Weight of overhauling load, lb

s = Distance load travels, ft

Thus, the total energy to be absorbed by a brake stopping an overhauling load is:

$$E_t = KE_l + KE_r + PE$$

Example 10 illustrates how energy absorption for Example 8 would be determined for one stop.

Example 10: Determine the total energy absorbed by a brake in one stop.

In Example 8, the calculation for total energy to be absorbed would be as follows.

First, calculate the kinetic energy of the linear load. The load weight was 4,940 lb and the velocity is 19 ft/min or 0.317 ft/sec. The kinetic energy is:

$$KE_l = \frac{Wv^2}{2g} = \frac{4,940 \times 0.317^2}{2 \times 32.2}$$

$$KE_l = 7.71 \text{ ft-lb}$$

Next, calculate the kinetic energy for the rotational load. The motor inertia is 0.65 lb-ft² and the drum inertia reflected to the brake shaft speed is 0.0067 lb-ft². The total rotational inertia at the brake motor shaft is,

$$\begin{aligned} Wk_r^2 &= Wk_m^2 + Wk_d^2 \\ &= 0.65 + 0.0067 \\ Wk_r^2 &= 0.6567 \text{ lb-ft}^2 \end{aligned}$$

And the kinetic energy of the rotating components is,

$$\begin{aligned} KE_r &= \frac{Wk_r^2 \times N_B^2}{5,875} \\ &= \frac{0.6567 \times 1,150^2}{5,875} \end{aligned}$$

$$KE_r = 147.8 \text{ ft-lb}$$

Now, calculate the potential energy converted to kinetic energy due to the change in position of the load while descending. A descending load is the most severe case since potential energy is transformed to kinetic energy that the brake must absorb. A 25 lb-ft brake was selected in Example 8. The 25 lb-ft static torque rating is converted to dynamic torque,

$$\begin{aligned} T_d &= T_s \times 0.8 \\ &= 25 \times 0.8 \\ T_d &= 20 \text{ lb-ft} \end{aligned}$$

Of this torque, 13.0 lb-ft is required to overcome the overhauling load as determined in Example 8. The dynamic torque available to decelerate the load is,

$$\begin{aligned} T_d &= T_t - T_m \\ &= 20 - 13 \\ T_d &= 7 \text{ lb-ft} \end{aligned}$$

The stopping time resulting from this dynamic torque is,

$$\begin{aligned} t &= \frac{Wk_r^2 \times N_M}{308 \times T_d} \\ &= \frac{0.691 \times 1,150}{308 \times 7} \\ t &= 0.369 \text{ sec} \end{aligned}$$

Where, $Wk_r^2 = 0.690 \text{ lb-ft}^2$ is the total

inertia the brake is to retard as determined in Example 8. With the load traveling at 19.0 ft/min or 0.317 ft/sec, the distance it will travel is,

$$\begin{aligned} s &= \frac{1}{2} vt \\ &= \frac{1}{2} \times 0.317 \times 0.369 \\ s &= 0.059 \text{ lb-ft} \end{aligned}$$

Wire the brake through a dedicated relay on overhauling loads where stop time or distance is critical. The potential energy transformed to kinetic energy in this distance would be,

$$\begin{aligned} PE &= W_s \\ &= 4,940 \times 0.059 \\ PE &= 291 \text{ ft-lb} \end{aligned}$$

Thus, the total energy to be absorbed by the brake would be,

$$\begin{aligned} E_T &= KE_r + KE_s + PE \\ &= 7.71 + 147.8 + 291 \\ E_T &= 447 \text{ ft-lb} \end{aligned}$$

The 25 lb-ft brake selected in Example 8 should be capable of absorbing 447 ft-lb of energy. The brake's maximum kinetic energy absorption rating should exceed this value.

Motor slip and test loads (150% of load) should be considered both in sizing and thermal calculations.

Brakes overheated in testing will require inspection before using in the standard application.

Heat Dissipation in Cyclic Applications

In general, a brake will repetitively stop a load at the duty cycle that a standard electric motor can repetitively start the load. A brake's thermal capacity is based upon the heat it can absorb and dissipate while cycling. The thermal capacity ratings for brakes are listed in the specification tables for specific brake models.

The energy that a brake is required to absorb and dissipate by a given power transmission system is determined from the total inertia of the load and system, the rotating or linear speed of the load, and the number of times the load is to be stopped in a given time period. The rate of energy dissipation is expressed in horsepower seconds per minute (hp-sec/min). Other common units for energy rates, such as foot pounds per second (ft-lb/sec), can be converted to hp-sec/min using the conversion factors given in the technical data section.

Refer to the Thermal Capacity Chart for use above 104°F (40°C) ambient temperature.

For applications demanding optimum brake performance, such as high inertial loads and frequent stops, the rate of energy dissipation required by the system is determined using the following formulas. *The calculated rate of energy dissipation should not exceed the thermal capacity of the brake. Thermal dissipation*

requirements exceeding the brake's rating may result in overheating of the brake to a point where torque falls appreciably. The friction material of the brake could glaze, carbonize or fail.

For rotating or linear loads, the rate at which a brake is required to absorb and dissipate heat when frequently cycled is determined by the relationship:

$$TC = \frac{Wk_r^2 \times N_B^2 \times n}{3.2 \times 10^6}$$

Where, TC = Thermal capacity required for rotating or linear loads
hp-sec/min

Wk_r^2 = Total system inertia reflected to brake, lb-ft²

N_B = Shaft speed at brake, rpm

n = Number of stops per minute, not less than 1

$$3.2 \times 10^6 = \text{Constant}$$

The rotating speed enters the formula as a squared function. Therefore, thermal requirements are of particular significance in systems where the brake will be operated at high speeds.

$$TC = \frac{E_T \times n}{550}$$

Where, TC = Thermal capacity required for overhauling loads
hp-sec/min

E_T = Total energy brake absorbs, ft-lb

n = Number of stops per minute, not less than 1

$$550 = \text{Constant}$$

For overhauling loads, the rate at which a brake is required to absorb and dissipate heat when frequently cycled is determined by the relationship:

Example 11 illustrates how the required thermal capacity would be determined for Example 4.

Example 11: Determine the thermal capacity required to stop a rotating load frequently.

Referring back to Example 4, the flywheel will be stopped 20 times per minute.

The required thermal capacity of the 6 lb-ft brake selected in this example is determined as follows.

The total inertial load the brake is to retard is 0.15 lb-ft². The shaft speed of the brake motor is 1,800 rpm. Therefore, the required thermal capacity is,

$$\begin{aligned} TC &= \frac{Wk_r^2 \times N_B^2 \times n}{3.2 \times 10^6} \\ &= \frac{0.15 \times 1,800^2 \times 20}{3.2 \times 10^6} \end{aligned}$$

$$TC = 3.0 \text{ hp-sec/min}$$

The 6 lb-ft brake selected in Example 4 should have a thermal capacity rating equal to or greater than 3.0 hp-sec/min.

A brake with greater thermal capacity will result in greater wear life.

If productivity is to be improved in Example 4 by increasing the cycle rate, the maximum number of stops per minute is determined by the rated thermal capacity of the brake. If the 6 lb-ft brake selected in Example 4 has rated thermal capacity of 9 hp-sec/min, the maximum permissible stops per minute would be determined by transposing the above formula to,

$$\begin{aligned}n_{\max} &= \frac{TC_{\text{rated}} \times (3.2 \times 10^6)}{WK_f^2 \times N_{\text{H}}^2} \\ &= \frac{9 \times (3.2 \times 10^6)}{0.15 \times 1,800^2} \\ n_{\max} &= 59 \text{ stops/min}\end{aligned}$$

So, the brake could be operated up to 36 times per minute without exceeding its ability to absorb and dissipate the heat generated by the frequent stops and meet the maximum solenoid cycle rating. *Cycle rate cannot exceed the solenoid cycle rate appearing in the catalog.*

Electrical Considerations

Please see Super-Mod dimensional data section.

Environmental Considerations

Brakes with standard open enclosures when mounted on NEMA C-face motors are drip-proof, except where a manual release lever has a clearance opening in the housing. The standard enclosure is commonly used on open, drip-proof and enclosed motors operating indoors or in protected outdoor environments.

NEMA 4, IP 54 is available on most brake models and are commonly used for outdoor installations, or where there are moist, abrasive or dusty environments. Standard and severe duty NEMA 4 enclosures are available in some brake series.

Brakes of various styles and materials for above or below deck on ships and dockside installation are available. The materials are usually specified by the ship designers or Navy specification MIL-B-16392C. Brakes are also available to meet MIL-E-17807B for shipboard weapon and cargo elevators. Refer to Marine, Maritime and Navy catalog pages.

Brakes Listed by Underwriters Laboratories, Inc. are available for use in hazardous locations, including Class I, Groups C and D; and Class II, Groups E, F and G. Motor-mounted, hazardous-location electric disc brakes are listed only when mounted to a Listed hazardous-location motor of the same Class and Group at the motor manufacturer's facility, and where the combination has been accepted by UL. This procedure completes the hazardous duty assembly of the brake. However, foot-mounted hazardous-location disc brakes that are Listed are also available for coupling to a motor, and may be installed by anyone.

Hazardous-location brakes are *not* gasketed unless indicated in the brake description. The enclosure prevents flame propagation to the outside atmosphere through controlled clearances. Protection from weather and washdowns must be provided. If the brake is used in a high humidity or low temperature environment, internal electric heaters should be used.

Standard ambient temperature range for brake operation is from 20°F (-7°C) to 104°F (40°C). Refer to Thermal Ratings section for brake operation at higher ambient temperatures. Heaters may be available for brake operation at low ambient temperatures and high humidity environments. Ductile iron construction and heaters are recommended for prolonged cold climate use.

Conclusion

The spring-set, electrically released disc brake is an important accessory to electric motors used in cycling and holding operations. It is available in a wide variety of enclosures. In most applications, a brake requires no additional wiring, controls or auxiliary electrical equipment. It is simple to maintain since the replaceable items, the friction discs, can be easily changed.

Many spring-set motor brakes are equipped with features such as simple wear adjustment to provide optimum friction disc life, visual wear indicator, torque adjustment and manual release. Featured on some types of brakes is automatic adjustment to compensate for friction disc wear. This feature eliminates the need for periodic adjustment and is advantageous in remote or inaccessible locations. Not all of the brakes on the market provide all of these features, but there are many Stearns motor brakes offering these features.

Care should be exercised in properly selecting a brake giving due consideration to torque as well as environment and thermal requirements. On applications where all the pertinent information is not available, selection must be based on previous experience of the designer and user, as well as the brake manufacturer, and should be confirmed by tests under actual operating conditions. If the brake is selected with reasonable allowances made for extremes in operating conditions, it will perform its task with little attention or maintenance.

Formulas

The following formulas cover the basic calculations used in brake application engineering.

Required	Given	Formula
Full load motor torque (T_{flmt}), lb-ft	Horsepower (P), hp Shaft speed (N), rpm 5252 = Constant	$T_{flmt} = \frac{5252 \times P}{N}$
Average dynamic braking torque (T_d), lb-ft	Total inertia reflected to brake (Wk^2), lb-ft ² Shaft speed at brake (N), rpm Desired stopping time (t), seconds 308 = Constant	$T_d = \frac{Wk^2 \times N}{308 \times t}$
Static torque (T), lb-ft	Force (F), lb Pulley or drum radius, (R), ft	$T = F \times R$
Overhauling dynamic torque reflected to brake shaft (T_o), lb-ft	Weight of overhauling load (W), lb Linear velocity of descending load (V), ft/min Shaft speed at brake (N), rpm 0.158 = Constant	$T_o = \frac{0.158 \times W \times V}{N}$
Static torque of brake (T_s), lb-ft (General Guideline)	Dynamic braking torque required (T_d), lb-ft 0.8 = Constant (derating factor)	$T_s = \frac{T_d}{0.8}$
Inertia of rotating load reflected to brake shaft (Wk_b^2), lb-ft ²	Inertia of rotating load (Wk_L^2), lb-ft ² Shaft speed at load (N_L), rpm Shaft speed at brake (N_B), rpm	Equivalent $Wk_b^2 = Wk_L^2 \left(\frac{N_L}{N_B} \right)^2$
Equivalent inertia of linear moving load reflected to brake shaft (Wk_w^2), lb-ft ²	Weight of linear moving load (W), lb Linear velocity of load (V), ft/min Shaft speed at brake (N_B), rpm 2 = Constant	Equivalent $Wk_w^2 = W \left(\frac{V}{2\pi N_B} \right)^2$
Kinetic energy of rotating load, (KE_r), ft-lb	Inertia of rotating load reflected to brake shaft (Wk_b^2), lb-ft ² Shaft speed at brake (N_B), rpm 5875 = Constant	$KE_r = \frac{Wk_b^2 \times N_B^2}{5875}$
Kinetic energy of linear moving load (KE_l), ft-lb	Weight of load (W), lb Linear velocity of load (v), ft/sec g = Gravitational acceleration constant, 32.2 ft/sec ²	$KE_l = \frac{Wv^2}{2g}$
Change in potential energy (PE), ft-lb	Weight of overhauling load (W), lb Distance load travels (s), ft	$PE = Ws$
Total energy absorbed by brake (E_T), ft-lb	Total linear kinetic energy, (KE_L), ft-lb Total rotary kinetic energy (KE_R), ft-lb Potential energy converted to kinetic energy (PE), ft-lb	$E_T = KE_L + KE_R + PE$
Thermal capacity required for rotational or linear moving loads (TC), hp-sec/min	Total system inertia reflected to brake shaft (Wk_T^2), lb-ft ² Shaft speed at brake (N_B), rpm Number of stops per minute (n), not less than one $3.2 \times 10^6 = \text{Constant}$	$TC = \frac{Wk_T^2 \times N_B^2 \times n}{3.2 \times 10^6}$
Thermal capacity required for overhauling loads (TC), hp-sec/min	Total energy brake absorbs (E_T), ft-lb Number of stops per minute (n), not less than one 550 = Constant	$TC = \frac{E_T \times n}{550}$
Linear velocity, ft/min	N = rpm Diameter (D), ft	$V = N\pi D$