

## Direct NEMA 48C & 56C Mounting Brakes AAB 321 & 322 Series Brakes



AAB 321 Series

### Key Industries:

- Agriculture
- Automation
- Material handling
- Packaging

### Features:

- Out-of-box torque
- Integrated brake housing design to keep brake coil cool
- Field replaceable coil
- Splined friction disc with anti-rattle features
- 321 Series IP 40
- 322 Series IP 54

The AAB 321 and 322 series brakes are designed to provide dynamic stopping or holding torque for high cycling applications. These units are highly reliable and deliver out-of-box torque and quiet operation. Their simplified assembly makes for a practical solution with minimal wear components that equates to a reduction in maintenance. The brake series have a flexible design that can be customized to fit a variety of applications.

### Additional Options Offered for our 321 & 322 Series Brakes:

- Internal rectifier
- Quick-set rectifiers
- Brake release indicator switch
- Brake-to-motor gasket
- Thru-shaft
- Conduit box

### Benefits of our 321 & 322 Series Brakes:

- Designed for high cycling applications
- Out-of-box torque – no burnishing required
- Enclosed design to keep elements out
- Quiet operation
- Integrated enclosure design keeps brake coil cool for longer life

### Why Stearns 321 & 322 Series Brakes:

- Years of experience in the brake industry
- Designed for long life
- Fewer wear components for maintenance reduction
- Available in IP 40 or IP 54 for better protection against environment

# Technical Information

48C

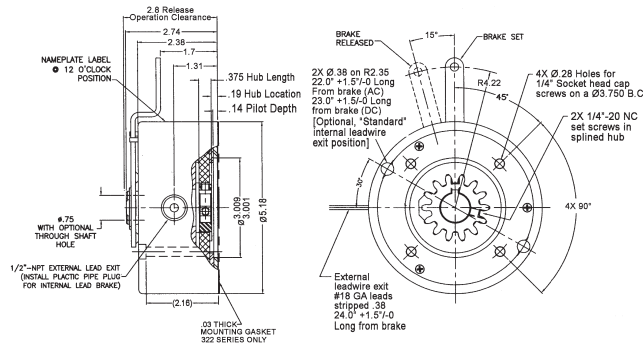

56C

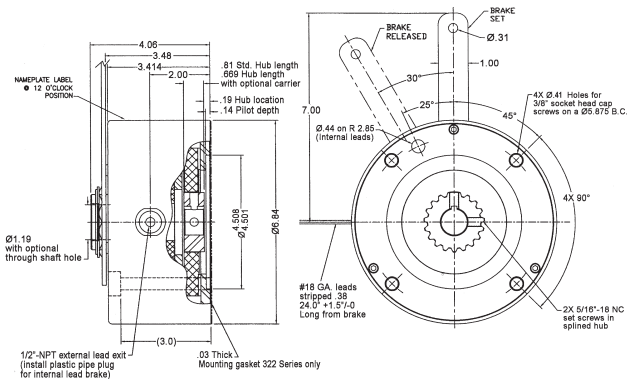

## Technical Characteristics

MOTOR FRAME	321 SERIES MODEL NUMBER	322 SERIES MODEL NUMBER	NOMINAL STATIC TORQUE LB-FT (NM)	APPROX. WEIGHT		POWER (WATTS)	HUB AND DISC INERTIA (OZ-IN-SEC <sup>2</sup> )
				LBS	KG		
48C	3-21-83XF	3-22-83XF	1.5 (2)	9.5	4.3	20	1.2 x 10 <sup>-2</sup>
	3-21-84XF	3-22-84XF	3 (4)				
	3-21-85XF	3-22-85XF	6 (8)				
	3-21-86XF	3-22-86XF	8.3 (11)				
56C	3-21-93XG	3-22-93XG	3 (4)	23	10.4	31	15.5 x 10 <sup>-2</sup>
	3-21-94XG	3-22-94XG	6 (8)				
	3-21-95XG	3-22-95XG	10 (14)				
	3-21-96XG	3-22-96XG	15 (20)				
	3-21-98XG	3-22-98XG	25 (34)				

Note: Available as standard or w/manual release

(414) 272-1100  
[stearnsbrakes.com](http://stearnsbrakes.com)

Stearns  
 5150 International Drive, Cudahy, WI 53110  
 Stearns is a registered trademark of Rexnord Corporation  
 STS-005\_LTR

**Stearns**<sup>®</sup>