

## Installation and Service Instructions for Self Adjust Brakes 82,000 Series (rev. A)

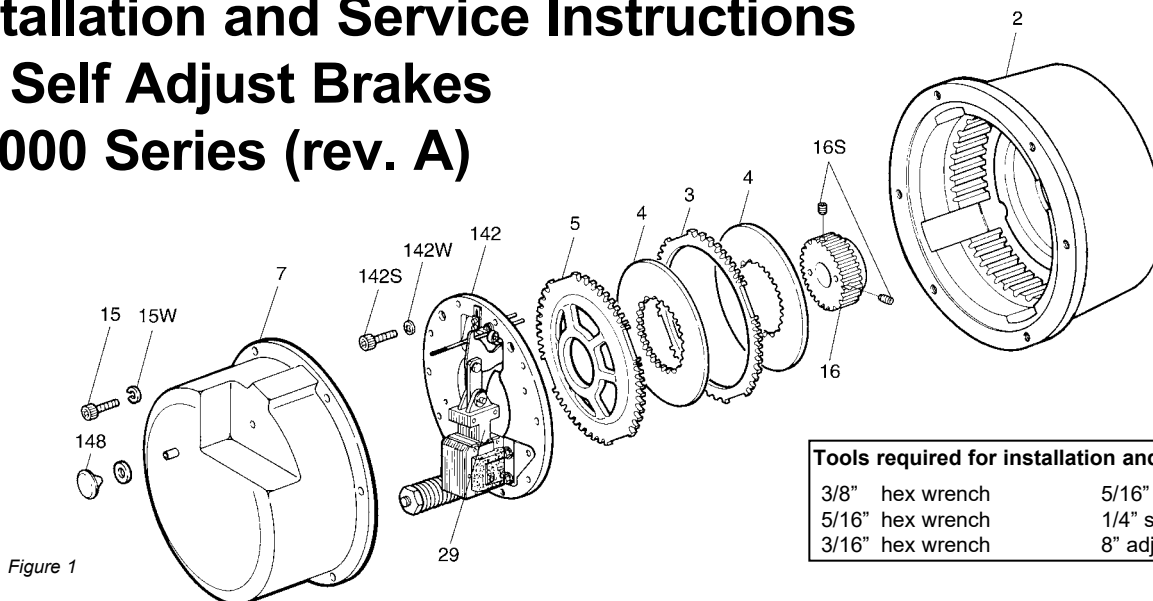

Figure 1

### Tools required for installation and servicing:

3/8" hex wrench	5/16" nut driver
5/16" hex wrench	1/4" screwdriver
3/16" hex wrench	8" adjustable wrench

<b>Stearns®</b> www.stearnsbrakes.com		<b>CRUS</b>	
<small>SEE INSTALLATION AND SERVICE SHEET OR INSTALLATION LABEL INSIDE OF HOUSING BEFORE INSTALLING, OPERATING, OR SERVICING BRAKE</small>			
SERIAL NUMBER:			
MODEL NUMBER:			
TORQUE:		LB-FT	
ENCLOSURE RATING:			
HZ	VOLTS	INRUSH/HOLDING AMPS	VOLTS INRUSH/HOLDING AMPS
MOUNTING:		Rexnord Industries, LLC	
IP RATING:		Stearns Division	
CUST P/N:		Cudahy, WI 53110	

### Important

Please read these instructions carefully before installing, operating, or servicing your Stearns Brake. Failure to comply with these instructions could cause injury to personnel and/or damage to property if the brake is installed or operated incorrectly. For definition of limited warranty/liability, contact Rexnord Industries, LLC, Stearns Division, 5150 International Dr., Cudahy, WI 53110, (414) 272-1100.

### Caution

1. Installation and servicing must be made in compliance with all local safety codes including Occupational Safety and Health Act (OSHA). All wiring and electrical connections must comply with the National Electric Code (NEC) and local electric codes in effect.
2. Use of this brake in atmospheres containing explosive gases and dusts must be in accordance with NEC article 501. This brake is not suitable for use in certain atmospheres containing explosive gases and dusts. HazLoc inspection authorities are responsible for verifying and authorizing the use of suitably designed and installed HazLoc equipment. When questions arise consult local Authority Having Jurisdiction (AHJ).
3. To prevent an electrical hazard, disconnect power source before working on the brake. If power disconnect point is out of sight,

lock disconnect in the offposition and tag to prevent accidental application of power.

4. Make certain power source conforms to the requirements specified on the brake nameplate.
5. Be careful when touching the exterior of an operating brake. Allow sufficient time for brake to cool before disassembly. Surfaces may be hot enough to be painful or cause injury.
6. Do not operate brake with housing removed. All moving parts should be guarded.
7. Installation and servicing should be performed only by qualified personnel familiar with the construction and operation of the brake.
8. For proper performance and operation, only genuine Stearns parts should be used for repairs and replacements.
9. After usage, the brake interior will contain burnt and degraded friction material dust. This dust must be removed before servicing or adjusting the brake.  
DO NOT BLOW OFF DUST using an air hose. It is important to avoid dispersing dust into the air or inhaling it, as this may be dangerous to your health.
  - a) Wear a filtered mask or a respirator while removing dust from the inside of a brake.
  - b) Use a vacuum cleaner or a soft brush to remove dust from the brake. When brushing, avoid causing the dust to become airborne. Collect the dust in a container, such as a bag, which can be sealed off.
10. **Caution!** While the brake is equipped with a manual release to allow manual shaft rotation, the motor should not be run with the manual release engaged, to avoid overheating the friction disc(s).

### General Description

This series of brake is spring-set, electrically released. They contain two to four rotating friction discs (4) driven by a hub (16) mounted on the motor or other shaft.

**Note:** Fan-guard mounted brakes requiring IP56 protection may require additional sealing measures beyond seals provided with this brake. Pressurized sprays aimed at the fan and brake hub surfaces can result in fluid migration along the motor shaft and keyway, and into the brake. The use of an appropriate sealant such as RTV or a forsheda seal is advised.

### Operating Principle

This series contains two or more friction discs (4) assembled alternately between the endplate (2) friction surface, stationary disc(s) (3) and pressure plate (5). The stationary components are restrained from rotating by being keyed into the endplate. With the brake released, all disc pack components are free to slide axially and the friction disc(s) to rotate.

Brake release occurs when the solenoid coil is electrically energized, causing the solenoid plunger to travel a specified distance and through a lever system, overcoming the pressure spring force. This action releases the clamping force on the disc pack, thereby allowing the friction disc(s) and brake hub to rotate.

Brake sets and torque is produced when electric current to the solenoid coil is interrupted, thereby collapsing the solenoid magnetic field. The solenoid plunger returns to its original de-energized position allowing the lever arm to move forward by virtue of the compressed torque springs. This action compresses the disc pack components which applies a retarding torque to the brake hub and ultimately restores the brake to a spring-set static condition.

# BRAKE MOUNTING

- 1** Remove manual release knob.  
Remove housing screws.  
Remove housing.

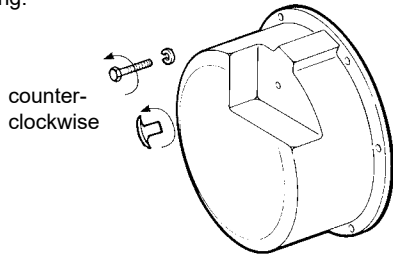

- 2** A. Push plunger down.  
B. Pull manual release to hold plunger.  
C. Remove support plate screws.

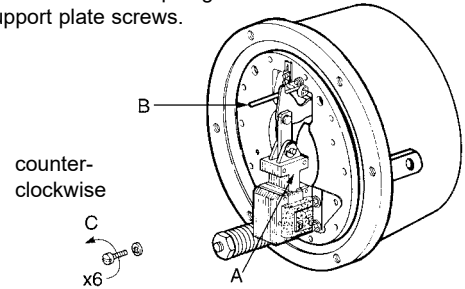

- 3** Lift off support plate.  
Remove disc pack.

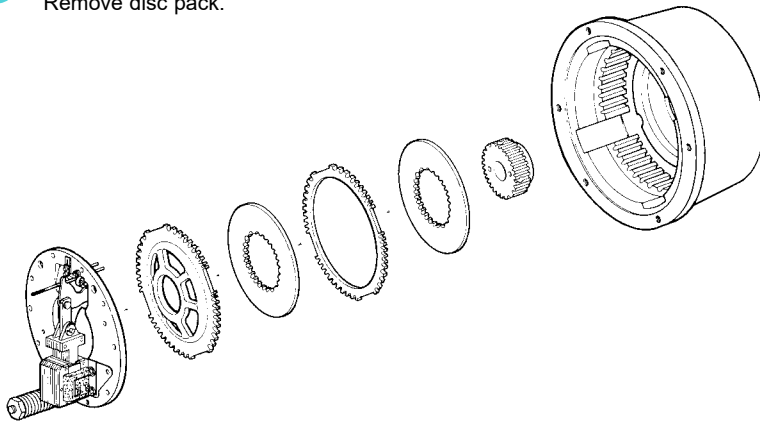

- 4** A. Position endplate on motor register.  
B. Insert four mounting bolts and tighten.  
(Torque per manufacturer specification)

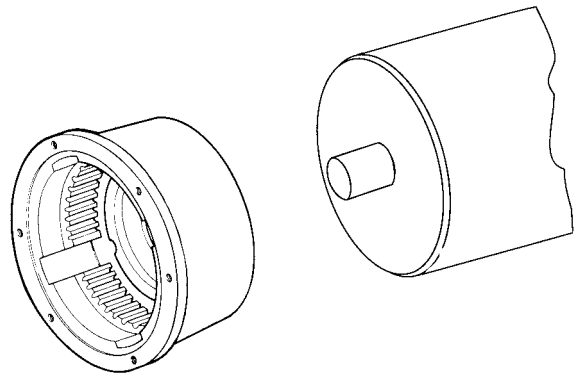

- 5** A. Position hub on shaft so that the inner surface is flush with motor register.  
Torque to: 5/16" - 156 in-lb; (18 Nm)  
3/8" - 288 in-lb; (33 Nm)  
1/2" - 625 in-lb; (70 Nm)  
3/4" - 2150 lb-in; (240 Nm)

- B. Reassemble disc pack in reverse order of removal.\*

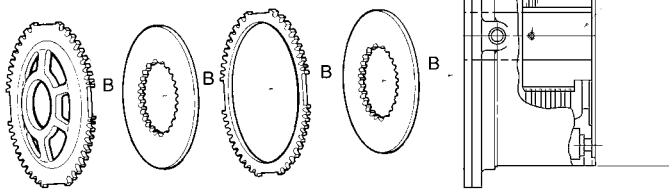

\* For vertical bakes refer to Service Instruction Sheet 8-078-932-06.

- 6** A. Route lead wires through conduit hole.  
B. Position support plate on endplate.  
C. Insert six mounting screws with lockwashers; tighten to 85-100 lb-in.

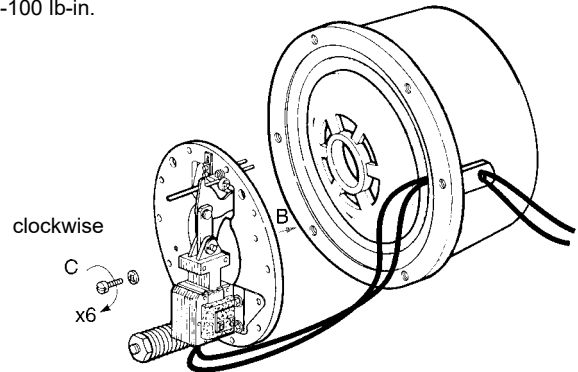

- 7** AC coils are 50/60 hz, single phase rated. Power supply to coil must not have current or frequency limiting output that is less than the coil requirement. Voltage supply to the coil must be within  $\pm 10\%$  of nameplate rating.

**\*Caution:** Keep wiring away from pinch points.

## Coil Wiring

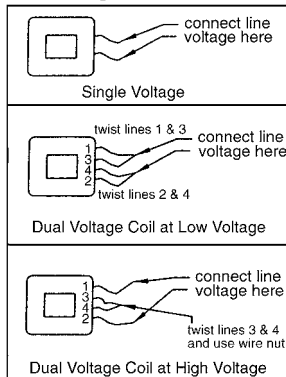

- 8** Replace housing.  
Tighten housing screws to 130 lb-in and release knob to 50 in-lb.

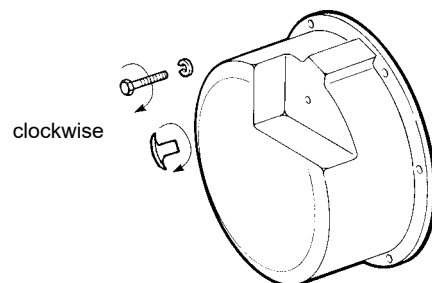

**General Maintenance**

**Warning!** Any mechanism or load held in position by the brake should be secured to prevent possible injury or damage to equipment before any disassembly of the brake is attempted or the manual release knob or lever is operated on the brake. Observe all cautions listed at the beginning of this manual.

**Note:** Do not lubricate any part of the brake as this may cause a malfunction and/or a loss of torque.

**Troubleshooting**

**A. If brake does not stop properly, coasts or overheats:**

1. Check that manual release knob is not in released mode.
2. Check for excessively worn, charred or broken friction discs.
3. Check that hub has not loosened and shifted on motor shaft.
4. Check that friction discs slide freely over hub. Clean hub and /or file burrs and nicks if required.
5. Check that stationary disc(s) and/or pressure plate can move freely in endplate and that they are not warped from overheating.
6. Check endplate slots for wear in the areas where stationary disc(s) and/or pressure plate make contact. Grooves in slots can prevent free disc movement and result in torque loss, stationary disc or friction disc breakage.
7. On vertically mounted brakes, check that springs are installed correctly. Check for wear on plunger guide bracket.
8. Confirm that the pressure spring nut (19) is properly tightened against the spacer (134) under the nut. Spring length should be measured from the cast surface of the support plate to the bottom side of the spring nut. Spring lengths are based on the brake fully assembled, using a new

disc pack. Spring length will increase as the disc pack wears.

9. Check solenoid air gap (see page 4). Adjust if necessary.

Torque (lb-ft)	Compressed Spring Length
125	4-23/32
175	4-23/32
230	4-27/32
330	5-3/32
440	5-3/32
550	5-3/32

10. Check that solenoid linkage can move freely. It requires approximately 18 lbs of pressure on the 125 lb-ft; 23 lbs on the 175, and 230 lb-ft; 28 lbs on 330, 440 and 550 lb-ft to seat solenoid plunger correctly functioning brake.
11. Check voltage reading at coil terminals against coil voltage rating.
12. Check that brake coil is energized at the same time as, or prior to, motor and de-energized at the same time, or after, motor.
13. If stopping time exceeds 1 second, or if the application requires more than five stops per minute, check the thermal requirements to stop load against the thermal capacity of the brake.
14. Check for excessive voltage drop in motor line when motor is started. Check wire gauge of supply line against motor starting current and solenoid inrush current. Measure voltage drop at solenoid coil terminals during maximum inrush current condition. To accomplish this, insert a block of wood, or other non-magnetic material, between solenoid plunger and frame. Block thickness should approximately equal solenoid air gap. Energize motor and brake simultaneously, take reading and

immediately shut down. This is to prevent motor, brake, or solenoid burnup.

**B: If brake hums, solenoid pulls in slowly, or coil burns out:**

1. Check Items A-7, A-9, A-11 and A-14.
2. Check if shading coils are broken.
3. Check for worn plunger guides or if plunger rubs on solenoid frame laminations.
4. Check for worn solenoid plunger and frame.
5. Check if solenoid is dirty.
6. Check if solenoid mounting screws have loosened.
7. Check for worn or binding linkage. For normal pressure required to seat solenoid plunger to frame see A-10.

**C. If brake is noisy during stopping and/or friction discs shatter:**

1. Check for worn motor bearings allowing shaft runout.
2. On foot mounted brakes, recheck alignment.
3. Check hub position on shaft. The outboard face of hub should protrude 3/32" to 1/8" beyond face of outboard friction disc.
4. Check motor shaft endfloat. It should not exceed 0.020".
5. Check concentricity of endplate and C-face register. Alignment must be within .007" concentricity and face runout. Shaft runout should be within .002" TIR.

**Vertical Brake Assembly**

Refer to service sheet 8-078-932-06 for proper spring and spacer positions when brake is assembled for vertical orientation.

**Note:** The older 82,000 series brake with vertical pins & springs; use sheet 8-078-932-05

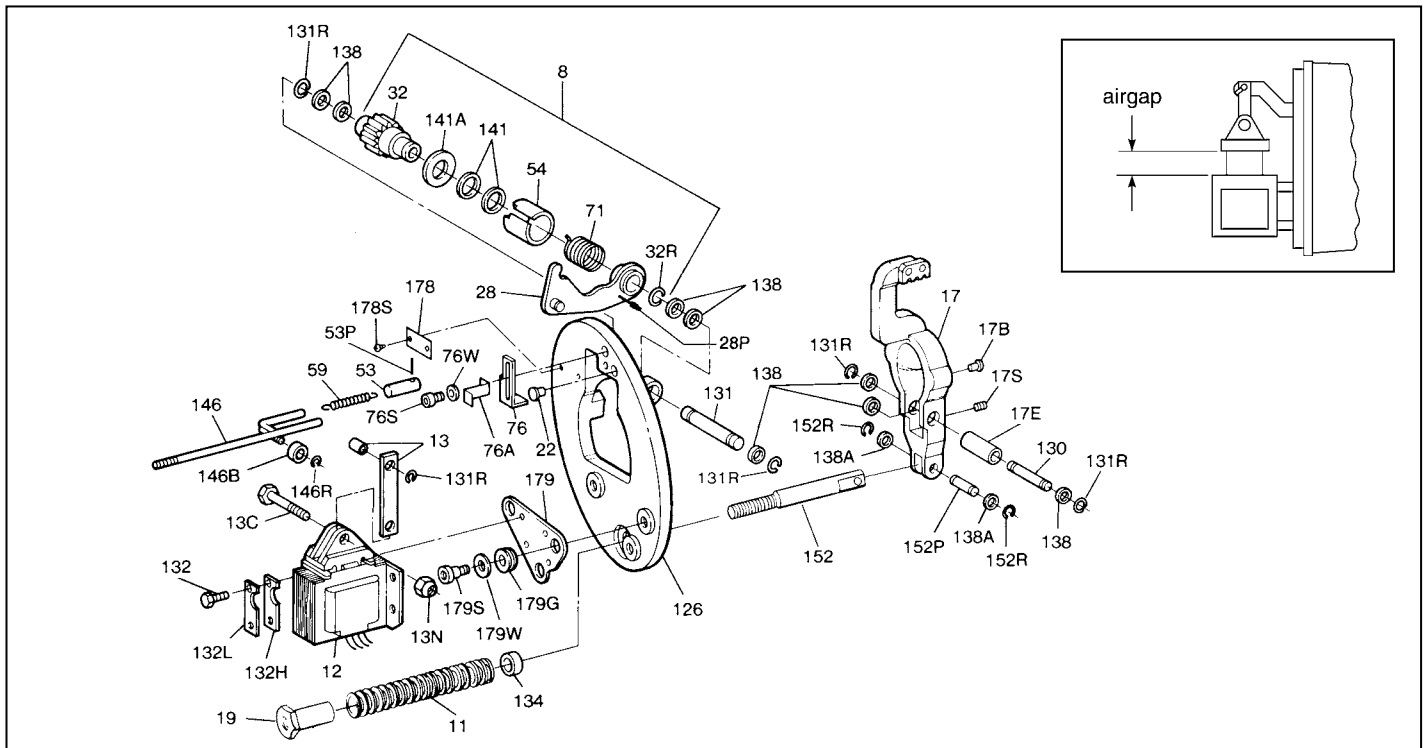

## AIR GAP ADJUSTMENT

**1**

**Note:** Refer to page 2, Brake Mounting, for removal and replacement of housing. Loosen two locking screws. Slide bracket outward to increase or inward to decrease air gap. Tighten screws to 75-78 lb-in.

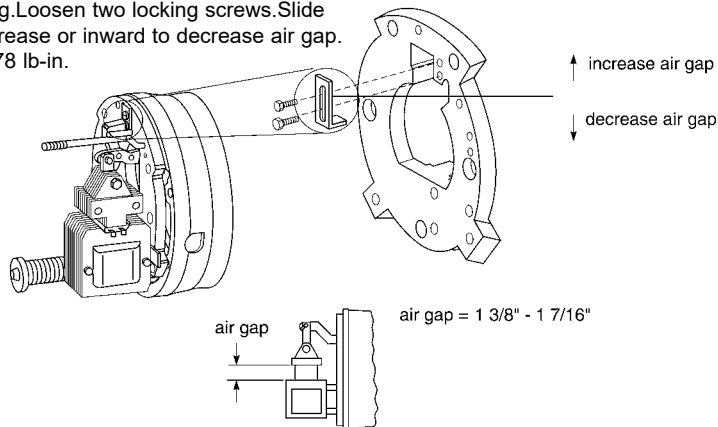

Wrap spring stop ① is positioned above the tang of the wrap spring ②

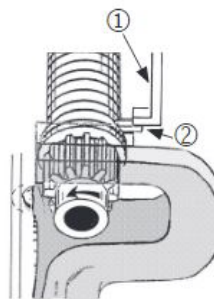

**Note:** Refer to page 2, Brake Mounting, for removal and replacement of housing.

## COIL REPLACEMENT

**1**

Disconnect coil lead wires from power source and pull them out of the brake.

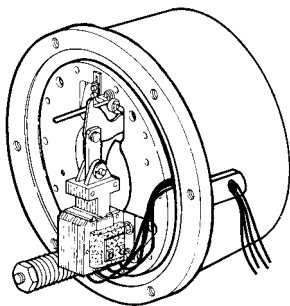

**Note:** Refer to page 2, Brake Mounting, for removal and replacement of housing.

**2**

A. Remove solenoid mounting screws.  
B. Lift solenoid frame away from plunger.

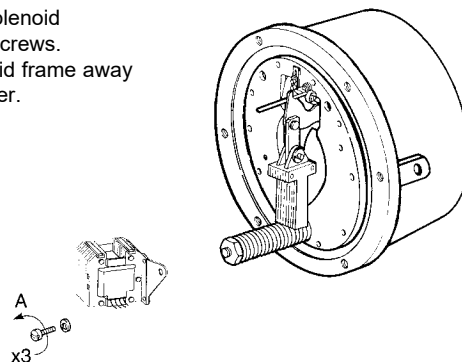

**3**

A. Remove guide screws.  
B. Lift guides out of coil.  
C. Push coil out of frame.

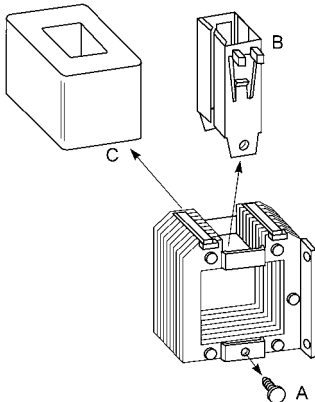

**4**

A. Insert new coil.  
B. Press plunger guides into place.  
C. Insert and tighten guide screws.

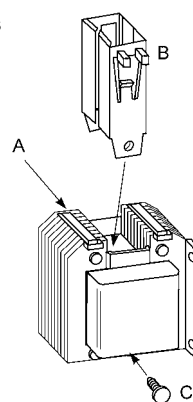

**5**

A. Slide coil assembly on to plunger.  
B. Insert mounting screws and tighten to 125 lb-in.

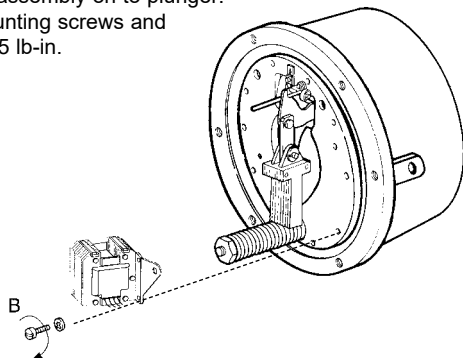

**6**

Reroute coil wires and reconnect to power supply.

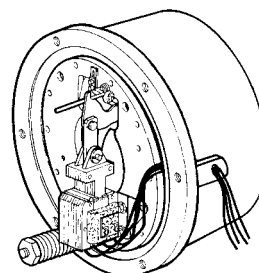

# FRICTION DISC REPLACEMENT

- 1** **Note:** Refer to page 2, Brake Mounting, for removal and reassembly of housing.
- A. Push plunger down.
  - B. Pull manual release to hold plunger.
  - C. Remove support plate screws.

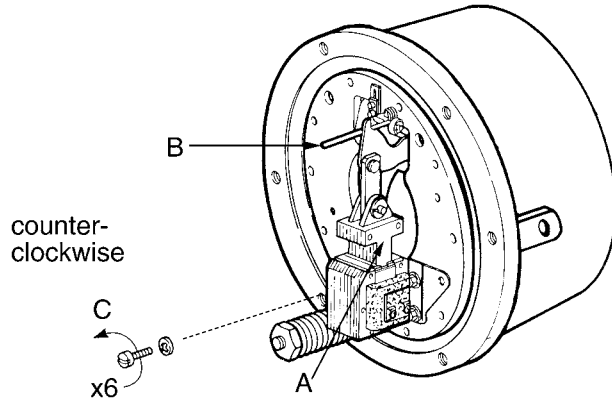

**Friction Disc Wear:**

- 1. Discs can wear to 50% of original thickness, or .187".
- 2. Entire wear of disc pack cannot exceed the thickness of a new disc, or .375

- 2**
- A. Remove support plate.
  - B. Remove disc pack components.
  - C. Discard old friction discs.

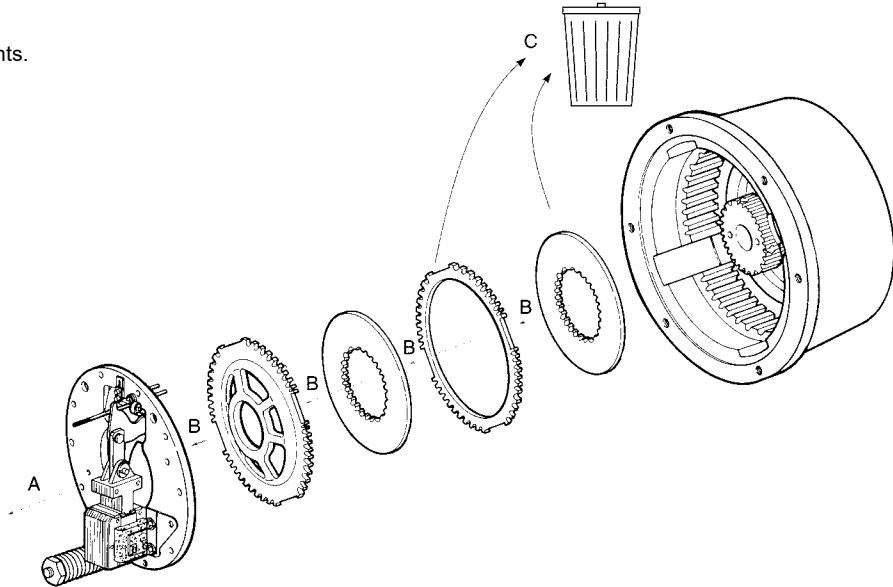

- 3**
- A. Install new friction discs and reassemble in reverse order of disassembly.\*
  - B. Position support plate and tighten six screws to 85-100 lb-in.

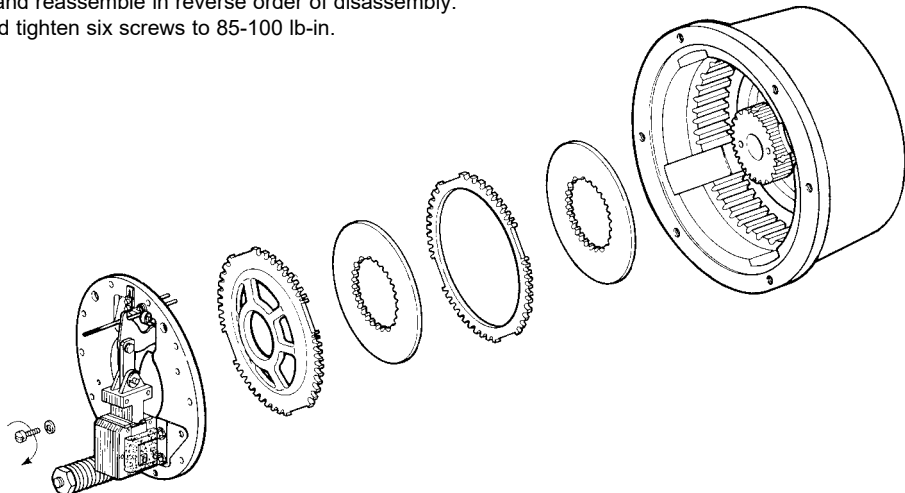

\* For vertical brakes refer to Service Instruction Sheet 8-078-932-06.

**Information required when ordering replacement parts:**

- Give part number of parts needed, brake model number and brake serial number. The brake model and serial number may identify special brakes not covered by this parts list.
- When ordering hubs, specify shaft diameter (hub bore) and keyway.
- Consult factory regarding support plate assembly for vertical and extra items.
- Enclosure Types are designated as follows: UL Type 1 (formerly referred to as standard)  
UL Type 4X (formerly referred to as BISSC washdown)

**General Information**

- For vertical details, see P/N 8-078-932-06 and SA-701.

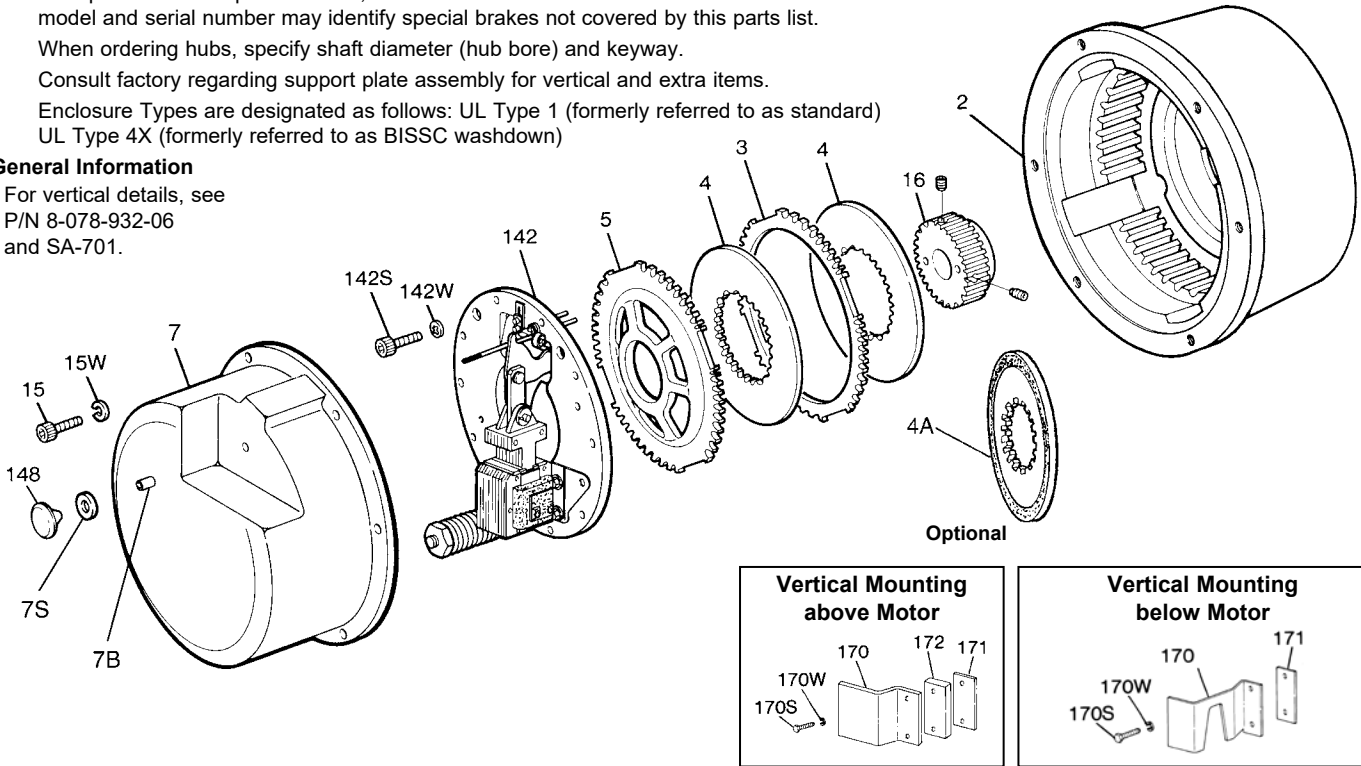

Torque (lb-ft)	125		175		230		330		440		550	
	AC		AC		AC		AC		AC		AC	
Current	1	4X	1	4X	1	4X	1	4X	1	4X	1	4X
Enclosure Type	1	4X	1	4X	1	4X	1	4X	1	4X	1	4X
Brake Model Number	1-082-011-02		1-082-012-02		1-082-021-02		1-082-022-02		1-082-031-02		1-082-032-02	
Part Number	1-082-041-02		1-082-042-02		1-082-051-02		1-082-052-02		1-082-061-02		1-082-062-02	
2	1		1		1		1		1		1	
2S		1		1		1		1		1		1
3	1	1	1	1	2	2	2	2	3	3	4	4
4	2	2	2	2	3	3	3	3	4	4	5	5
4A												
5					1	1	1	1			1	1
7	1	1	1	1	1	1	1	1	1	1	1	1
7B	1	1	1	1	1	1	1	1	1	1	1	1
7D	1	1	1	1	1	1	1	1	1	1	1	1
7S	1	1	1	1	1	1	1	1	1	1	1	1
15	6	6	6	6	6	6	6	6	6	6	6	6
15W	6	6	6	6	6	6	6	6	6	6	6	6
16	1	1	1	1								
69		1		1		1		1		1		1
140	1	1	1	1	1	1	1	1			1	1
142	1	1										
142S	6	6	6	6	6	6	6	6	6	6	6	6
142W	6	6	6	6	6	6	6	6	6	6	6	6
148	1	1	1	1	1	1	1	1	1	1	1	1

**TABLE 1**  
Components of Standard Horizontal AC Units

Item No.	Description	Part Number
2	Endplate (horizontal/vertical)	8-002-221-41
	Endplate (horizontal/vertical)	8-002-222-41
	Endplate and oil seal assembly (horizontal/vertical)	5-22-2011-40
	Endplate and oil seal assembly (horizontal/vertical)	5-22-2012-40
2S	Seal (component of endplate and seal assembly)	9-02-0015-00
3	Stationary disc	8-003-206-01
4	Friction disc	5-66-8420-00
4A	Carrier disc (horizontal only)	5-18-2001-00
5	Pressure plate	8-005-205-01
	Pressure plate	8-005-206-01
7	Housing, bearing and seal assembly (cast iron)	5-07-2012-00
optional	Housing, bearing and seal assembly (aluminum)	5-07-2112-00
7B	Housing bearing (component of Item 7)	9-04-0050-00
7D	Pipe plug (drain)	9-33-0325-00
7S	Housing seal (component of Item 7)	9-02-0017-00
15	Machine screw (housing)	9-17-3216-00
15W	Lock washer (housing)	9-45-1332-00
16	Hub and set screw assembly	5-16-2101-00
	Hub and set screw assembly	5-16-2102-00
	Hub and set screw assembly	5-16-2103-00
	Hub and set screw assembly	5-16-2104-00
69	Gasket (housing to endplate)	8-069-205-00
140	Lead wire bushing (endplate) (internal connection only)	8-140-002-11
	Lead wire bushing (endplate) (internal connection only)	8-140-002-13
142	Support plate assembly (see Table 3 for components)	5-42-2071-00-09
	Support plate assembly (see Table 3 for components)	5-42-2072-00-09
	Support plate assembly (see Table 3 for components)	5-42-2073-00-09
	Support plate assembly (see Table 3 for components)	5-42-2074-00-09
	Support plate assembly (see Table 3 for components)	5-42-2075-00-09
	Support plate assembly (see Table 3 for components)	5-42-2076-00-09
	Support plate assembly (see Table 3 for components)	5-42-2077-00-42
	Support plate assembly (see Table 3 for components)	5-42-2078-00-09
142S	Cap screw (support plate)	9-17-5016-00
142W	Conical spring washer (sup. plate) 1/4 I.D. x 9/16 O.D.	9-46-0006-00
148	Release knob	8-148-804-00

X = -02 (cast iron housing)  
-03 (cast aluminum housing)

				Torque (lb-ft)		125		175		230		330		440	
				Current		AC		AC		AC		AC		AC	
				Enclosure Type		1	4X	1	4X	1	4X	1	4X	1	4X
				Brake Model Number		1-082-011-0X	1-082-012-0X	1-082-021-0X	1-082-022-0X	1-082-031-0X	1-082-032-0X	1-082-041-0X	1-082-042-0X	1-082-051-0X	1-082-052-0X
Type of Modification	Item No.	Description (most items not shown)	Part Number	1-082-011-0X	1-082-012-0X	1-082-021-0X	1-082-022-0X	1-082-031-0X	1-082-032-0X	1-082-041-0X	1-082-042-0X	1-082-051-0X	1-082-052-0X		
Vertical Mounting above Motor	2	See Table 1 for endplate													
	3	Stationary disc	8-003-206-02	1	1	1	1	2	2	2	2	3	3		
	5	Pressure plate	8-005-205-02					1	1	1	1				
		Pressure plate	8-005-206-02	1	1	1	1					1	1		
	7	Housing and side release assembly	5-07-1002-00		1	1			1		1		1		
	Not Shown	Vertical spring kit	5-96-0205-00	1	1	1	1	1	1	1	1	1	1		
	170	Plunger guide bracket	<i>kit</i> 5-55-2002-00	1	1	1	1	1	1	1	1	1	1		
	170S	Cap screw (bracket)													
	170W	Lock washer (bracket)													
	171	Shim (bracket)													
172	Spacer														
	Release plate	} <i>components of support plate - vertical mounting</i>	8-170-102-00		1		1		1		1		1		
	Screw		9-16-3012-00		2		2		2		2		2		
	Lock nut		9-40-3730-00		2		2		2		2		2		
	Spring pin		9-32-4055-00		1		1		1		1		1		
	Release rod		8-146-201-01		1		1		1		1		1		
	Foot mounting kit, comprised of:		5-55-2022-00												
34	Foot mounting bracket	8-034-205-01	1	1	1	1	1	1	1	1	1	1			
34S	Cap screw	9-17-1624-00	4	4	4	4	4	4	4	4	4	4			
39W	Lock washer	9-45-0336-00	4	4	4	4	4	4	4	4	4	4			
Vertical Mounting below Motor	3	Stationary disc	8-003-206-02	1	1	1	1	2	2	2	2	3	3		
	5	Pressure plate	8-005-205-02					1	1	1	1				
		Pressure plate	8-005-206-02	1	1	1	1					1	1		
	Not Shown	Vertical spring kit	5-96-0206-00	1	1	1	1	1	1	1	1	1	1		
	170	Plunger guide bracket	8-170-205-00												
170S	Cap screw (bracket)	8-350-002-00	2	2	2	2	2	2	2	2	2	2			
170W	Lock washer (bracket)	9-45-0330-00	2	2	2	2	2	2	2	2	2	2			
171	Shim (bracket)	8-454-016-00	*	*	*	*	*	*	*	*	*	*			
Shaft through Housing	7	Housing, bearing and seal assembly	5-07-2014-00		1		1		1		1		1		
	24	Shaft bushing (specify bore)	8-024-202-01		1		1		1		1		1		
	24L	Set screw (shaft bushing)	9-20-3004-00		2		2		2		2		2		
	24S	Shaft seal (component of Item 7)	9-02-0010-00		1		1		1		1		1		
Brass Parts (horizontal brakes)	3	Stationary disc	8-003-208-01	1	1	1	1	2	2	2	2	3	3		
	4	Friction disc	8-004-208-00	2	2	2	2	3	3	3	3	4	4		
	5	Pressure plate	8-005-207-01					1	1	1	1				
		Pressure plate	8-005-208-01	1	1	1	1					1	1		
Space Heater Kit	Not shown	Heater (115 volt circuit)	5-27-2006-00	1	1	1	1	1	1	1	1	1	1		
		Heater (230 volt circuit)	5-27-2007-00	1	1	1	1	1	1	1	1	1	1		

\*As required.

Item No.	Description	Part Number	Brake Size Torque (lb-ft)			
			125	175	230	330
			440	550	AC	AC
8	Solenoid lever and pinion assembly (comprised of Items 28, 32, 32R, 54, 71, 141 and 141A)	5-66-7321-00	1	1	1	1
11	Pressure spring (green) Pressure spring (yellow) Pressure spring (red)	9-70-4601-00 9-70-6001-00 9-70-5801-00	1	1	1	1
13	Solenoid link and bearing assembly	5-55-2006-00	1	1	1	1
13C	Cap screw (solenoid link)	8-157-703-00	1	1	1	1
13N	Nut (solenoid link)	9-40-3732-00	1	1	1	1
17	Lever arm assembly	5-17-2001-00	1	1	1	1
17B	Pressure button	9-25-1908-00	2	2	2	2
17E	Eccentric sleeve (lever arm)	8-054-201-00	1	1	1	1
17S	Set screw (lever arm)	9-20-3004-00	2	2	2	2
19	Pressure spring nut	8-019-202-01	1	1	1	1
22	Solenoid lever stop	8-022-603-00	1	1	1	1
53	Manual release spring tube	8-053-201-00	1	1	1	1
53P	Roll pin (spring tube)	9-32-4012-00	1	1	1	1
59	Release spring	9-71-0004-00	1	1	1	1
76	Wrap spring stop	8-076-203-00	1	1	1	1
76A	Holding plate (wrap spring stop)	8-076-204-00	1	1	1	1
76S	Cap screw (spring stop)	9-17-2812-00	2	2	2	2
76W	Lock washer (spring stop)	9-45-1328-00	2	2	2	2
126	Support plate and bearing assembly	5-26-2004-00	1	1	1	1
130	Pivot pin (lever arm)	8-118-204-00	1	1	1	1
131	Pivot pin (solenoid lever)	8-131-201-00	1	1	1	1
131R	Retaining ring (pivot pin)	9-03-0020-00	5	5	5	5

**Table 3 (see Note)**  
Components of  
Support Plate Assemblies

Item No.	Description	Part Number	Brake Size Torque (lb-ft)			
			125	175	230	330
			440	550	AC	AC
132	Cap screw (solenoid mounting)	8-350-008-00	4	4	4	4
132H	Holding plate (solenoid mounting)	8-076-207-00	2	2	2	2
132L	Lock plate (solenoid mounting)	8-076-206-00	2	2	2	2
134	Pressure spring spacer	8-134-001-02	1	1		
	Pressure spring spacer	8-134-001-03			1	
	Pressure spring spacer	8-134-001-05				1
138	Bearing (washer type)	8-138-201-00	8	8	8	8
138A	Bearing (washer type)	8-138-701-00	2	2	2	2
146	Release rod	8-146-201-00	1	1	1	1
146B	Ball bearing (release rod)	9-01-6801-00	1	1	1	1
146R	Retaining ring (release rod)	9-03-0007-00	1	1	1	1
152	Pressure spring stud	8-152-201-00	1	1	1	1
152P	Pivot pin (spring stud)	8-118-202-00	1	1	1	1
152R	Retaining ring (spring stud)	9-03-0019-00	2	2	2	2
159	Brake release interlock kit (standard manual release)	5-55-2005-00	1	1	1	1
	Brake release interlock kit (side manual release)	5-55-2004-00	1	1	1	1
178	Instruction plate	8-078-054-00	1	1	1	1
178S	Drivescrew	9-25-1303-00	2	2	2	2
179	Solenoid mounting plate	8-179-205-01	1	1	1	1
179G	Grommet (mounting plate)	8-147-202-00	3	3	3	3
179S	Shoulder screw (mounting plate)	9-26-1108-00	3	3	3	3
179W	Washer (mounting plate)	8-138-202-00	3	3	3	3

**Table 3 (continued)**  
Components of  
Support Plate Assemblies

**Note:** Some brakes manufactured prior to the "-02" series had solenoid which were mounted on (4) rubber shock mounts. Conversion kits are available to replace these mounts. Kit 5-12-9595 replaces 1" diameter by 17/32" high mounts with 1/4-20 studs. Kit 5-12-9594 replaces 1-1/4" diameter by 3/4" high mounts with 5/16-18 studs. Kit 5-12-9593 must replace mounts on serial numbers B-960232 through 69 and B-989748.

**Table 4**  
Components of Solenoid and Coil Assemblies

Item	Description	Part Number	Torque (lb-ft)		
			125	330	
<b>AC Brakes</b>			<b>175</b>	<b>440</b>	
			<b>230</b>	<b>550</b>	
12	Solenoid assembly (AC)	5-12-5529-00	1	1	
12A	Size 9	115 Vac	5-96-6929-50	1	
		230 Vac	5-96-6929-52	1	
	Strength 3	Coil	460 Vac	5-96-6929-60	1
		575 Vac	5-96-6929-66	1	
	assembly	115/230 Vac	5-96-6929-56	1	
		230/460 Vac	5-96-6929-61	1	
	Size 9	115 Vac	5-96-6929-67	1	
		230 Vac	5-96-6929-69	1	
	Strength 4	Coil	460 Vac	5-96-6929-75	1
		575 Vac	5-96-6929-80	1	
assembly	115/230 Vac	5-96-6929-70	1		
	230/460 Vac	5-96-6929-81	1		

**Solenoid and Coil Assembly**

**Table 5**  
Contents of Assemblies and Kits

Item No.	Description
12	Solenoid assembly (5-12-55XX-00) 1 – Plunger 1 – Frame 2 – Lock plates 1 – Solenoid link cap screw 1 – Solenoid link nut
12A	Coil assembly (5-96-6929-XX) 1 – Coil 2 – Plunger guides 2 – Plunger guide screws
159	Brake switch kit (5-55-2004-00 or 5-55-2005-00) (brake release interlock switch - N.O.) 1 – Microswitch 1 – Bracket, microswitch 1 – Bracket, mounting 1 – Mounting hardware

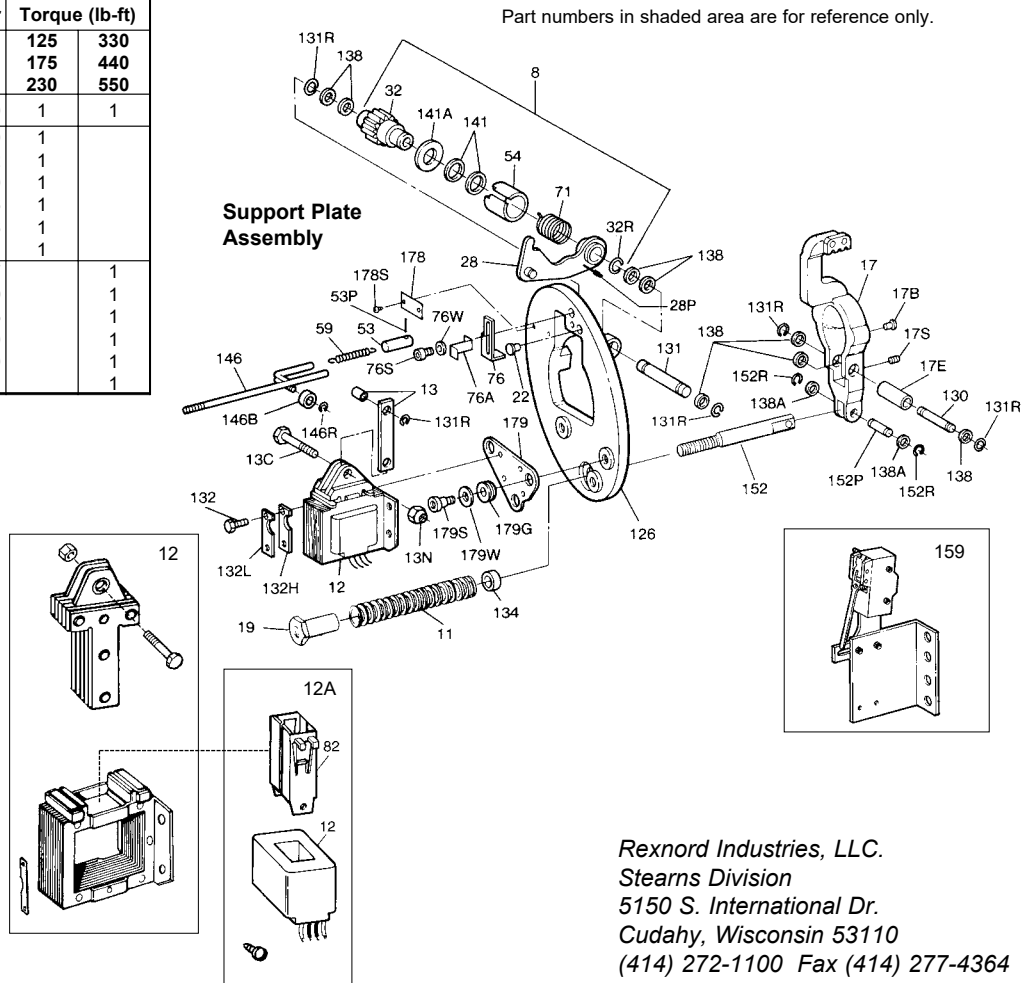

Rexnord Industries, LLC.  
Stearns Division  
5150 S. International Dr.  
Cudahy, Wisconsin 53110  
(414) 272-1100 Fax (414) 277-4364