

## Installation and Service Instructions for 86,000 Series Self-Adjust Brakes

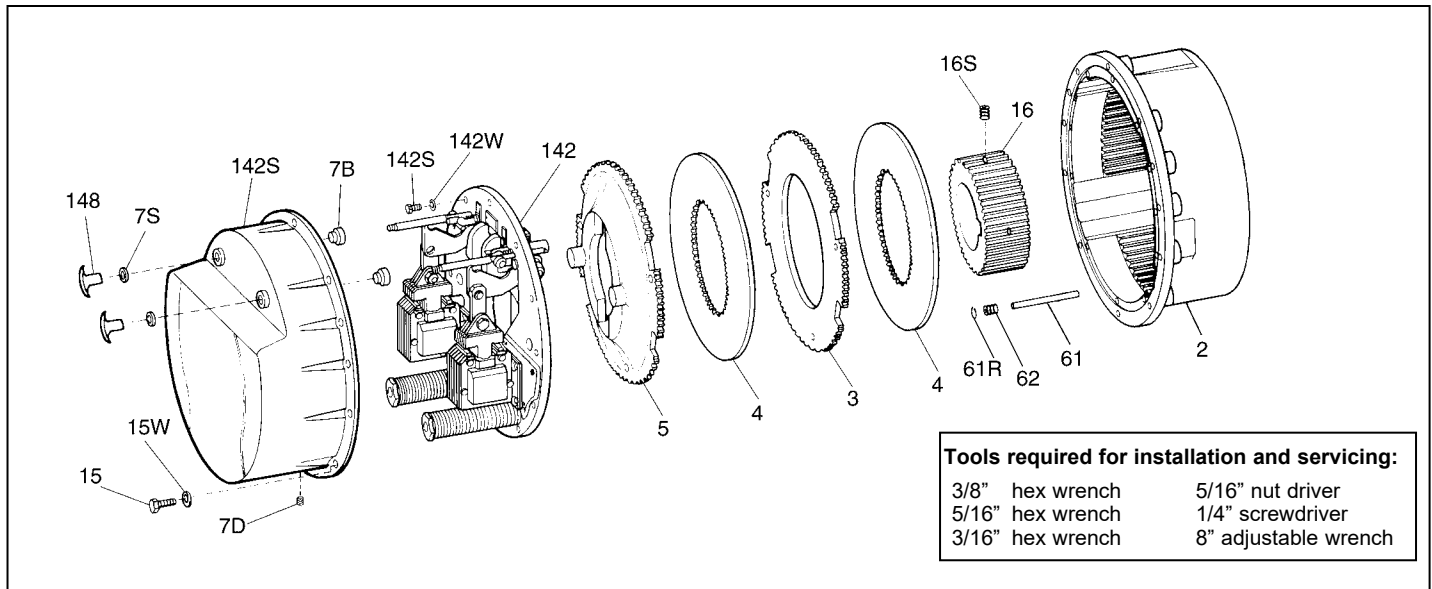

### Typical Nameplate

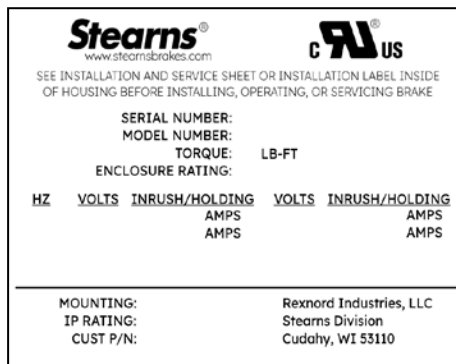

### IMPORTANT

Please read these instructions carefully before installing, operating, or servicing your Stearns Brake. Failure to comply with these instructions could cause injury to personnel and/or damage to property if the brake is installed or operated incorrectly. For definition of limited warranty/liability, contact Rexnord Industries, LLC, Stearns Division, 5150 International Dr., Cudahy, WI 53110, (414) 272-1100.

### Caution

- Installation and servicing must be made in compliance with all local safety codes including Occupational Safety and Health Act (OSHA). All wiring and electrical connections must comply with the National Electric Code (NEC) and local electric codes in effect.
- Use of this brake in atmospheres containing explosive gases and dusts must be in accordance with NEC article 501. This brake is not suitable for use in certain atmospheres containing explosive gases and dusts. **HazLoc** inspection authorities are responsible for verifying and authorizing the use of suitably designed and installed **HazLoc** equipment. When questions arise consult local **Authority Having Jurisdiction (AHJ)**.

- To prevent an electrical hazard, disconnect power source before working on the brake. If power disconnect point is out of sight, lock disconnect in the *off* position and tag to prevent accidental application of power.
- Make certain power source conforms to the requirements specified on the brake nameplate.
- Be careful when touching the exterior of an operating brake. Allow sufficient time for brake to cool before disassembly. Surfaces may be hot enough to be painful or cause injury.
- Do not operate brake with housing removed. All moving parts should be guarded.
- Installation and servicing should be performed only by qualified personnel familiar with the construction and operation of the brake.
- For proper performance and operation, only genuine Stearns parts should be used for repairs and replacements.
- After usage, the brake interior will contain burnt and degraded friction material dust. This dust must be removed before servicing or adjusting the brake.

DO NOT BLOW OFF DUST using an air hose. It is important to avoid dispersing dust into the air or inhaling it, as this may be dangerous to your health.

- Wear a filtered mask or a respirator while removing dust from the inside of a brake.
  - Use a vacuum cleaner or a soft brush to remove dust from the brake. When brushing, avoid causing the dust to become airborne. Collect the dust in a container, such as a bag, which can be sealed off.
- Caution!** While the brake is equipped with manual releases to allow manual shaft rotation, the motor should not be run with the manual releases engaged, to avoid overheating the friction disc(s).

### General Description

This series of brakes is spring-set, electrically released. They contain two to four rotating friction discs (4) driven by a hub (16) mounted on the motor or other shaft.

**Note:** Fan-guard mounted brakes requiring IP54 & IP 56 protection may require additional sealing measures beyond seals provided with this brake. Pressurized sprays aimed at the fan and brake hub surfaces can result in fluid migration along the motor shaft and keyway, and into the brake. The use of an appropriate sealant such as *RTV* or a *forsheda* seal is advised.

### Operating Principle

This series contain two or more friction discs (4) assembled alternately between the endplate (2) friction surface, stationary disc(s) (3) and pressure plate (5). The stationary components are restrained from rotating by being keyed into the endplate. With the brake released, all disc pack components are free to slide axially and the friction disc(s) to rotate.

Brake release occurs when the solenoid coils are electrically energized, causing the solenoid plungers to travel a specified distance and through a lever system, overcoming the pressure spring force. This action releases the clamping force on the disc pack, thereby allowing the friction disc(s) and brake hub to rotate.

Brake sets and torque is produced when electric current to the solenoid coils are interrupted, thereby collapsing the solenoid magnetic fields. The solenoid plungers return to their original de-energized position allowing the lever arms to move forward by virtue of the compressed torque springs. This action compresses the disc pack components which applies a retarding torque to the brake hub and ultimately restores the brake to a spring-set static condition.

# BRAKE MOUNTING

- 1** Remove manual release knobs.  
Remove housing screws.  
Remove housing.

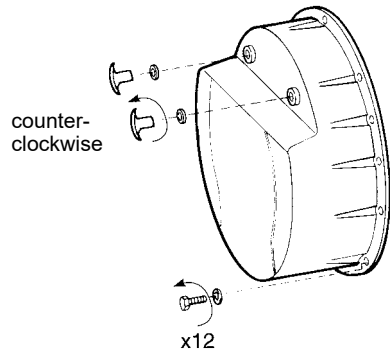

- 2** A. Push plungers down.  
B. Pull manual releases to hold plungers.  
C. Remove support plate screws.

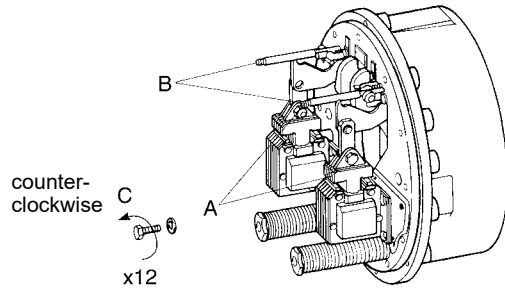

- 3** A. Lift off support plate.  
B. Remove retaining clips.  
C. Remove disc pack and centralizing springs.

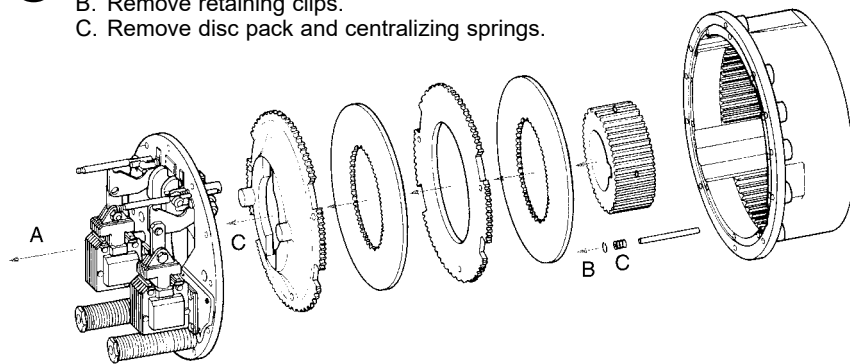

- 4** A. Position endplate on motor register.  
B. Insert four mounting bolts and tighten.  
(Torque per manufacturer specification)

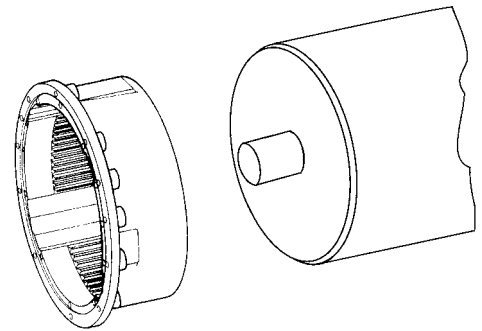

- 5** A. Position hub on shaft so that the inner spline surface is flush with machined friction surface.  
Torque to: 1/2" diameter – 620 lb-in (70 Nm)  
5/8" diameter – 1325 lb-in (150 Nm)  
3/4" diameter – 2150 lb-in (240 Nm)  
7/8" diameter – 5200 lb-in (585 Nm)  
1" diameter – 7100 lb-in (800Nm)  
B. Reassemble disc pack in reverse order of removal.

\*For vertical brakes, refer to Service Instruction Sheet 8-078-936-05.

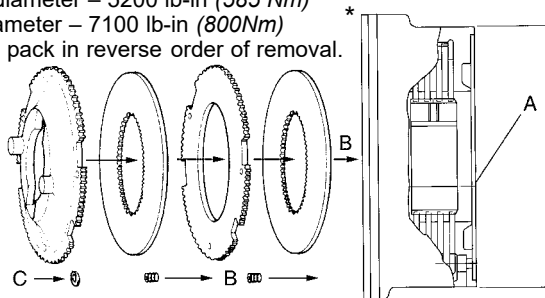

- 6** A. Route lead wires through conduit hole.  
B. Position support plate on endplate.  
C. Insert three mounting screws; tighten to 85-100 lb-in.

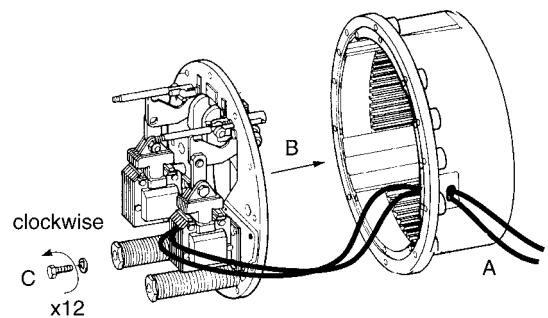

- 7** AC coils are 50/60 hz, single phase rated. Power supply to coil must not have current or frequency limiting output that is less than the coil requirement. Voltage supply to the coil must be within  $\pm 10\%$  of nameplate rating.\*

**Caution:** Keep wiring away from pinch points.

Coils are wired in parallel with a jumper on the terminal strip on the support plate.

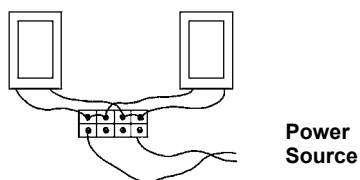

- 8** Replace housing.  
Tighten housing screws to 130 lb-in and release knob to 50 lb-in.

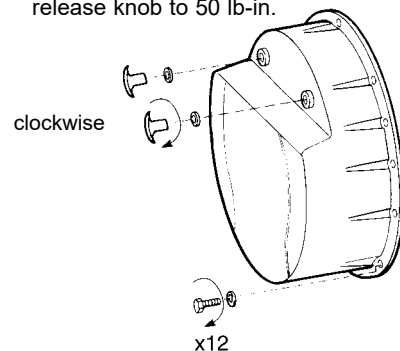

## General Maintenance

**Warning!** Any mechanism or load held in position by the brake should be secured to prevent possible injury to personnel or damage to equipment before any disassembly of the brake is attempted or before the manual release knob or lever is operated on the brake. Observe all cautions listed at the beginning of this manual.

**Note:** Do not lubricate any part of the brake as this may cause malfunction and/or a loss of torque.

## Troubleshooting

### A. If brake does not stop properly, coasts or overheats:

1. Check that manual release knobs are not in released mode.
2. Check for excessively worn, charred or broken friction discs.
3. Check that hub has not loosened and shifted on motor shaft.
4. Check that friction discs slide freely over hub. Clean hub and/or file burrs and nicks if required.
5. Check that stationary disc(s) and/or pressure plate can move freely in endplate and that they are not warped from overheating.
6. Check endplate slots for wear in the areas where stationary disc(s) and/or pressure plate make contact. Grooves in slots can prevent free disc movement and result in torque loss, stationary disc or friction disc breakage.
7. On vertically mounted brakes, check that springs are installed correctly and that stationary disc(s) can slide freely

over vertical mounting pins. Check for wear on plunger guide bracket.

8. Check that pressure spring nut (19) was properly tightened. Correct compressed spring height should be approximately 5-5/32" with new friction discs. Measurement is from top face of support plate to bottom of the spring nut.
9. Check solenoid air gap and other items per *Self-Adjust Maintenance*, Section III-C. Adjust if necessary
10. Check that solenoid linkages can move freely. It requires approximately 28 lbs of pressure to seat solenoid plunger to frame on a correctly functioning brake.
11. Check voltage reading at coil terminals against coil voltage rating.
12. Check that brake coils are energized at the same time as, or prior to, motor and de-energized at the same time, or after, motor.
13. If stopping time exceeds 1 second, or if the application requires more than five stops per minute, check the thermal requirements to stop load against the thermal capacity of the brake.
14. Check for excessive voltage drop in motor line when motor is started. Check wire gauge of supply line against motor starting current and solenoid inrush current. Measure voltage drop at solenoid coil terminals during maximum inrush current condition. To accomplish this, insert a block of wood, or other non-magnetic material, between solenoid plunger and frame. Block thickness should approximately equal solenoid air gap. Energize motor and brake simultaneously, take reading and immediately shut down. This is to prevent motor, brake, or solenoid burnup.

### B. If brake hums, solenoid pulls in slowly, or coil burns out:

1. Check Items A-7, A-9, A-11 and A-14.
2. Check if shading coils are broken.
3. Check for worn plunger guides or if plunger rubs on solenoid frame laminations.
4. Check for worn solenoid plunger and frame.
5. Check if solenoid is dirty.
6. Check if solenoid mounting screws have loosened.
7. Check for worn or binding linkage. For normal pressure required to seat solenoid plunger to frame see A-10.

### C. If brake is noisy during stopping and/or friction discs shatter:

1. Check for worn motor bearings allowing shaft runout.
2. On foot mounted brakes, recheck alignment.
3. Check hub position on shaft. The outboard face of hub should protrude 3/32" to 1/8" beyond face of outboard friction disc.
4. Check motor shaft endfloat. It should not exceed 0.020".
5. Check concentricity of endplate and C-face register. Alignment must be within .007" concentricity and face runout. Shaft runout should be within .002" TIR.

## Vertical Spring Assembly

Refer to service sheet 8-078-936-05 for proper spring and spacer positions when brake is assembled for vertical orientation.

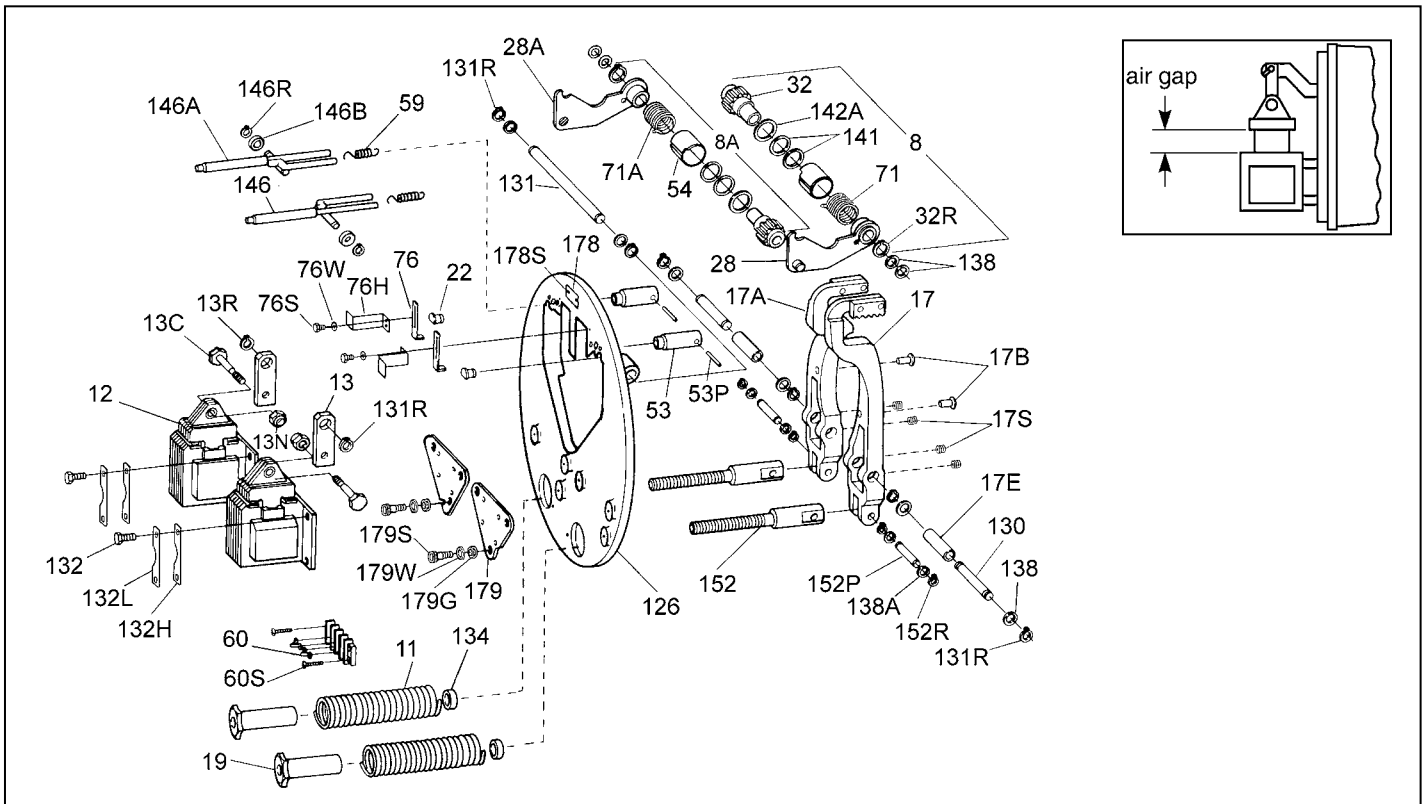

## AIR GAP ADJUSTMENT

**1**

**Note:** Refer to page 2, Brake Mounting, for removal and replacement of housing. Loosen two locking screws. Slide bracket outward to increase air gap or inward to decrease air gap. Tighten screws 75-78 lb-in.

Wrap spring stop to decrease air gap. The spring stop is positioned above the tang of the wrap spring.

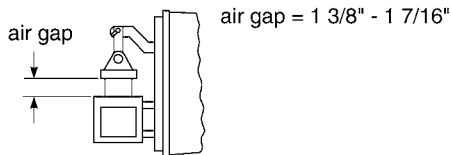
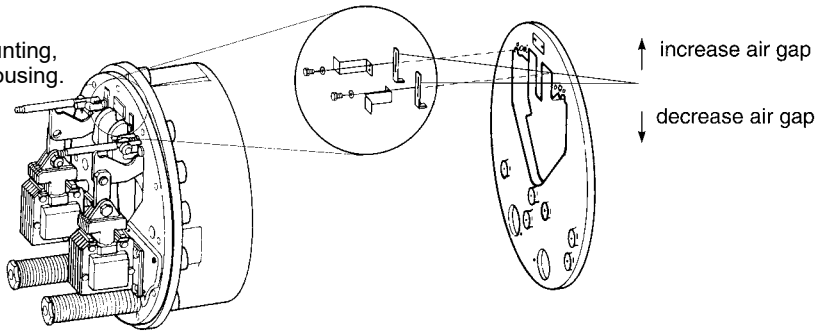
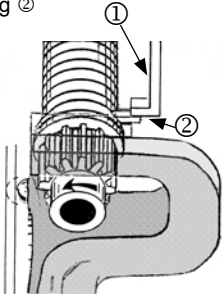

## COIL REPLACEMENT

**1**

Disconnect coil lead wires from terminal block.

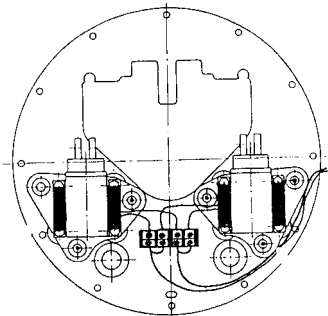

**Note:** Refer to page 2, Brake Mounting, for removal and replacement of housing.

**2**

A. Remove solenoid mounting screws.  
B. Lift solenoid frame away from plunger.

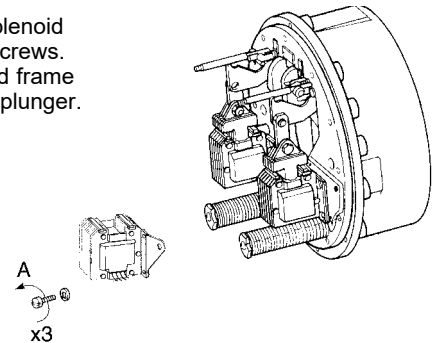

**3**

A. Remove guide screws.  
B. Lift guides out of coil.  
C. Push coil out of frame.

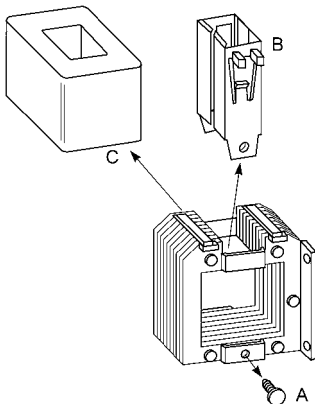

**4**

A. Insert new coil.  
B. Press plunger guides into place.  
C. Insert and tighten guide screws.

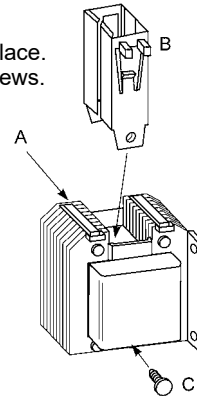

**5**

A. Slide coil assembly onto plunger.  
B. Insert mounting screws and tighten to 125 lb-in.

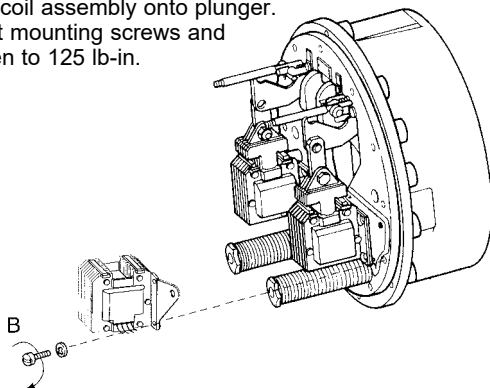

**6**

Reconnect coil leadwires to terminal block.

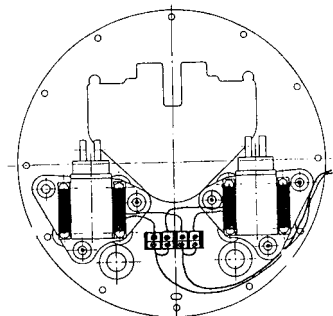

# FRICION DISC REPLACEMENT

- 1** **Note:** Refer to page 2, Brake Mounting, for removal and reassembly of housing.
- A. Push plungers down.
  - B. Pull manual releases to hold plungers.
  - C. Remove support plate screws.

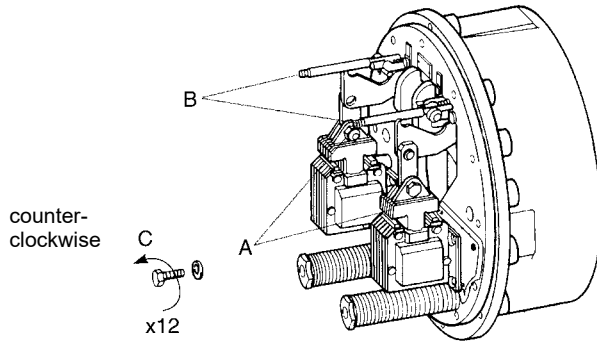

### Friction Disc Wear:

1. Discs can wear to 50% of original thickness, or .187".
2. Entire wear of disc pack cannot exceed the thickness of a new disc, or .375".

- 2**
- A. Remove support plate.
  - B. Remove retaining clips.
  - C. Remove disc pack components.
  - D. Discard old friction discs.

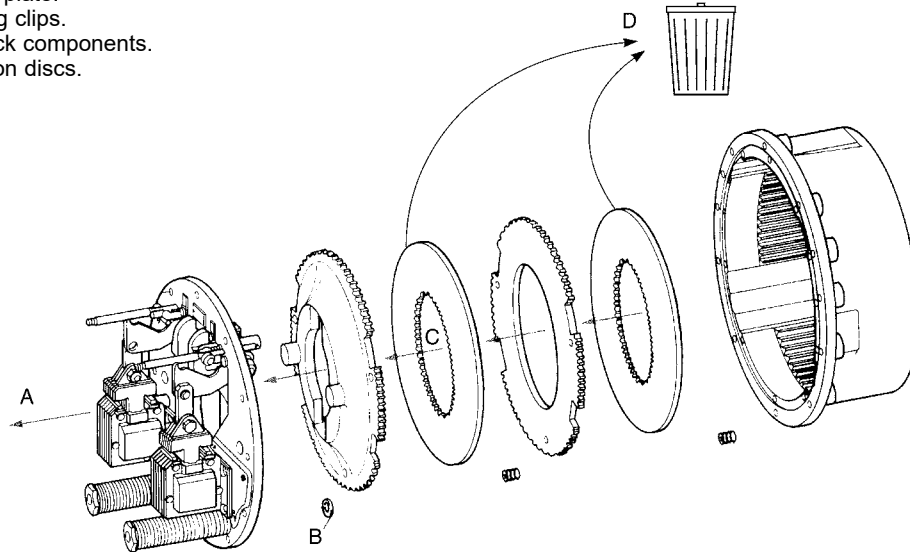

- 3**
- A. Install new friction discs and reassemble in reverse order of disassembly.\*
  - B. Reinstall the retaining clips.
  - C. Position support plate and tighten twelve screws to 85-100 lb-in.

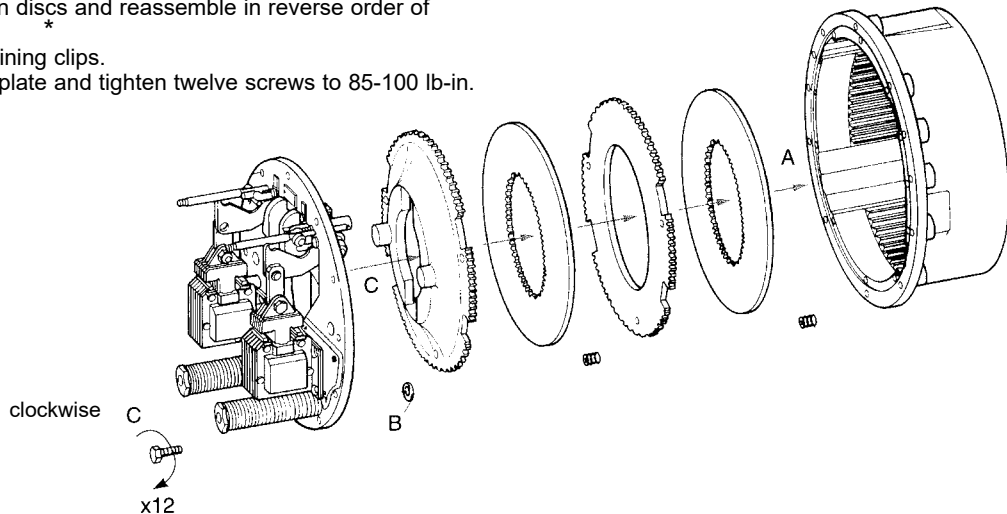

\* For vertical brakes refer to Service Instruction Sheet 8-078-936-05.

**Information required when ordering replacement parts:**

- Give Part Number of parts needed, Brake Model Number and Brake Serial Number. The Brake Model and Serial Number may identify special brakes not covered by this parts list.
- When ordering hubs, specify shaft diameter (hub bore) and keyway.
- Enclosure Types are designated as follows:  
**UL Type 1** (formerly referred to as standard)  
**UL Type 4X** (formerly referred to as BISSC washdown)

**General Information**

- For 86,100-02 see Table 1A.
- For vertical details consult factory.

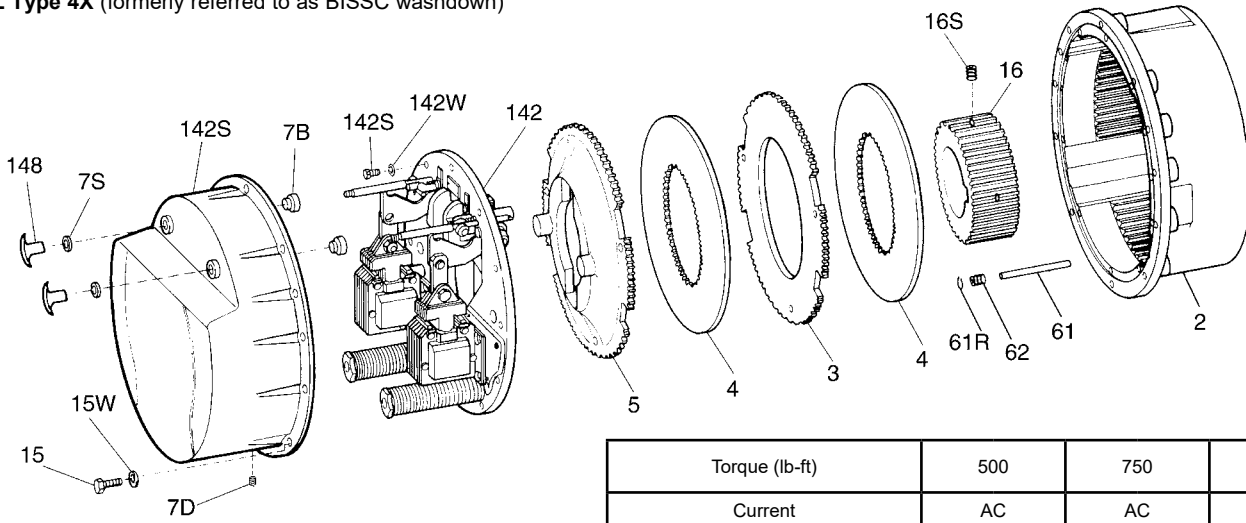

**TABLE 1:**  
**Components of Standard Horizontal AC Units**

Item No.	Description	Part Number ↓	Torque (lb-ft)		500		750		1000	
			Current		AC		AC		AC	
			Enclosure Type		1	4X	1	4X	1	4X
			1-086-021-02	1-086-022-02	1-086-031-02	1-086-032-02	1-086-041-02	1-086-042-02		
2	Endplate	8-002-662-03	1		1		1		1	
2S	Endplate and oil seal assembly Seal (component of endplate and seal assembly)	5-22-6605-00 9-02-0083-00		1		1		1		1
3	Stationary disc	8-003-661-01	1	1	2	2	3	4	3	3
4	Friction disc	5-66-8464-00	2	2	3	3	4	4		4
5	Pressure Plate	8-005-663-01	1	1						
	Pressure Plate	8-005-663-02			1	1			1	1
	Pressure Plate	8-005-663-03								
7	Housing, bearing and seal assembly	5-07-6602-00	1	1	1	1	1	1	1	1
7B	Housing bearing (component of Item 7)	8-021-663-00	2	2	2	2	2	2	2	2
7D	Pipe plug (drain)	9-33-0332-00	1	1	1	1	1	1	1	1
7S	Housing seal (component of Item 7)	9-02-0020-00	2	2	2	2	2	2	2	2
15	Cap screw (housing) socket head 5/16 - 18 x 1"	9-17-3116-00	12	12	12	12	12	12	12	12
15W	Lock washer (housing) spring 5/16" H.C.	9-45-1331-00	12	12	12	12	12	12	12	12
16	Hub and set screw assembly	5-16-6101-00	1							
	Hub and set screw assembly	5-16-6103-00			1					
	Hub and set screw assembly	5-16-6105-00					1			
	Hub and set screw assembly	5-16-6102-00		1						
	Hub and set screw assembly	5-16-6104-00				1				
	Hub and set screw assembly	5-16-6106-00								1
61	Centralizing pin	8-061-663-00	3	3						
	Centralizing pin	8-061-662-00			3	3				
	Centralizing pin	8-061-661-00					3	3		3
61R	Retaining ring (centralizing pin)	9-03-0028-00	3	3	3	3	3	3	3	3
62	Centralizing spring	9-70-1304-00	6	6	9	9	12	12		12
69	Gasket (housing to endplate) (not shown)	8-069-661-00		1		1				1
140	Leadwire bushing (endplate) (not shown) (internal connection only)	8-140-602-00	2	2	2	2	2	2		2
142	Support plate assembly (AC) (less coils) (see Table 2)	5-42-6621-00	1	1	1	1	1	1		1
142S	Cap screw (support plate) socket head 1/4-20 x 1-1/4"	9-17-5020-00	12	12	12	12	12	12	12	12
142W	Spring conical washer (support plate) 1/4 I.D. x 9/16 O.D.	9-46-0006-00	12	12	12	12	12	12	12	12
148	Release knob	8-148-804-00	2	2	2	2	2	2		2
<b>Floor Mounting</b>										
34	Floor stand kit (comprised of floor stand and cap screws)	5-55-6021-00	1	1	1	1	1	1		1
<b>Shaft through Housing</b>										
7	Housing, bearing and seal assembly	5-07-6604-00		1		1				1
24	Shaft bushing (specify bore)	8-024-601-01		1		1				1
24L	Set screw (shaft bushing)	9-22-1004-00		2		2				2
24S	Shaft seal (component of Item 7)	9-02-0080-00		1		1				1

\*See page 7 for Table 1A  
 Variable Endplate.

**TABLE 1A:**

Endplate (only variable) for 86,100-02 AC units (for mounting on NEMA C-face of motor frames 504UC, 505C, 504SC and 505SC)

Item No	Description	Part Number	Models Used On
A	Endplate Endplate and oil seal assembly	8-002-662-06 5-22-6611-00	1-086-1X1-02 and 1-086-1X5-02 1-086-1X2-02 and 1-086-1X6-02

**Note:** Term *left* or *right* applies when looking at support plate assembly from outboard face.

**TABLE 2:**

Components of Support Plate Assemblies

Item No.	Description	Part Number ↓	Current	AC
			Assembly Part Number →	5-42-6621-00
8	Solenoid lever and pinion assembly ( <i>right hand</i> ) (comprised of Items 28, 32, 32R, 54, 71, 141 & 141A)	5-66-7321-00		1
8A	Solenoid lever and pinion assembly ( <i>left hand</i> ) (comprised of Items 28A, 32, 32R, 54, 71A 141 & 141A)	5-66-7361-00		1
11	Pressure spring ( <i>red</i> )	9-70-5801-00		2
12	Solenoid assembly	see Table 3		2
13	Solenoid link/bearing assembly	5-55-6001-00		1
13C	Cap screw ( <i>solenoid link</i> )	8-157-703-00		2
13N	Nut ( <i>solenoid link</i> )	9-40-3732-00		2
17	Lever arm assembly ( <i>right hand</i> )	5-17-6601-00		1
17A	Lever arm assembly ( <i>left hand</i> )	5-17-6602-00		1
17B	Pressure button	9-25-1908-00		2
17E	Eccentric sleeve ( <i>lever arm</i> )	8-054-201-00		2
17S	Set screw ( <i>lever arm</i> ) 1/4 - 20 x 1/4"	9-20-3004-00		4
19	Pressure spring nut	8-019-201-00		2
22	Solenoid lever stop	8-022-603-00		2
28	Solenoid lever ( <i>right hand</i> ) (component of Item 8)			1
28A	Solenoid lever ( <i>left hand</i> ) (component of Item 8)			1
32	Pinion (components of Items 8 and 8A)			2
32R	Retaining ring (component of items 8 and 8A)			2
53	Spring tube ( <i>manual release</i> )	8-053-201-00		2
53P	Roll pin ( <i>spring tube</i> )	9-32-4012-00		2
54	Sleeve (component of Items 8 and 8A)			2
59	Release spring	9-71-0004-00		2
60	Terminal block	9-60-0925-00		1
60S	Machine screw ( <i>terminal block</i> )	9-10-2712-00		2
61	Terminal jumper	9-60-0803-00		2
71	Wrap spring ( <i>right hand</i> ) (component of Item 8)			1
71A	Wrap spring ( <i>left hand</i> ) (component of Item 8A)			1
76	Wrap spring stop	8-076-203-00		2
76H	Holding plate ( <i>previous design was flat plate</i> )	8-076-204-00		2
76S	Cap screw ( <i>spring stop</i> )	9-17-2812-00		4
76W	Lock washer ( <i>spring stop</i> )	9-45-1328-00		4
126	Support plate and bearing assembly	5-26-6607-00		1
130	Pivot pin ( <i>lever arm</i> )	8-118-204-00		2
131	Pivot pin ( <i>solenoid levers</i> )	8-131-601-00		1
131R	Retaining ring ( <i>pivot pins</i> )	9-03-0020-00		8
132	Cap screw hex head 5/16 - 18 x 1/2"	8-350-009-00		8
132H	Holding plate ( <i>solenoid mounting</i> )	8-076-665-00		4
132L	Lock plate ( <i>solenoid mounting</i> )	8-076-662-00		4
134	Spacer ( <i>pressure spring</i> )	8-134-001-05		2
138	Bearing ( <i>washer type</i> )	8-138-201-00		14
138A	Bearing ( <i>washer type</i> )	8-138-701-00		4
141	Spacer ( <i>wrap spring</i> ) (component of Items 8 and 8A)			4
141A	Spacer ( <i>wrap spring</i> ) (component of Items 8 and 8A)			2
146	Release rod ( <i>right hand</i> )	8-146-203-00		1
146A	Release rod ( <i>left hand</i> )	8-146-663-00		1
146B	Ball bearing ( <i>release rod</i> )	9-01-6801-00		2
146R	Retaining ring ( <i>release rod</i> ) Truarc 5100-25-ZD	9-03-0007-00		2
152	Pressure spring stud	8-152-201-00		2
152P	Pivot pin	8-118-202-00		2
152R	Retaining ring Truarc #5100-37	9-03-0019-00		4
178	Instruction plate	8-078-054-00		1
178S	Drivescrew	9-25-1303-00		2
179	Solenoid mounting plate	8-179-602-01		2
179G	Grommet ( <i>mounting plate</i> )	8-147-202-00		6
179S	Shoulder screw ( <i>mounting plate</i> )	9-26-1108-00		6
179W	Washer ( <i>mounting plate</i> )	8-138-202-00		6
Not Shown	Space Heater Kit (115v) (230v)	5-27-2008-00 5-27-2009-00		1 1

**Note:** Some brakes manufactured prior to the "-02" series had solenoids which were mounted on (4) rubber shock mounts. Conversion kit 5-12-9596-00 is available to replace these mounts.

## Support Plate Assembly

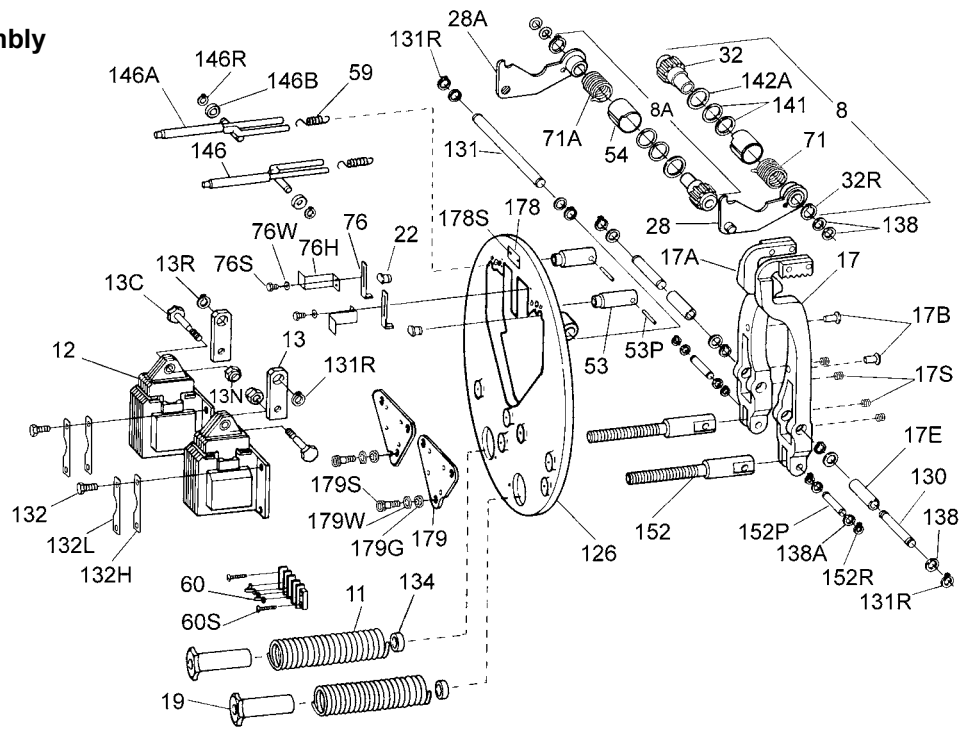

## Solenoid and Coil Assembly

TABLE 3 – Components of Solenoid and Coil Assemblies

Item	Description	Part Number
<b>AC Brakes</b>		
12*	Solenoid assembly (AC)	5-12-5521-00
12A	Size 9 Strength 4 coil assembly 60 Hz	115 Vac 230 Vac 460 Vac 575 Vac 5-96-6929-67 5-96-6929-69 5-96-6929-75 5-96-6929-80
159*	Brake release interlock switch kit	5-57-5504-00

\*AC brakes with the brake release interlock (N.O.) switch (Item 159) use the DC solenoid assembly for switch mounting.

TABLE 4

Contents of Assemblies and Kits

Item No.	Description
12	Solenoid assembly (5-12-55XX-00) 1 - Plunger 1 - Frame 2 - Lock plates 1 - Solenoid link cap screw 1 - Solenoid link nut
12A	Coil assembly (5-96-6929-XX) 1 - Coil 2 - Plunger guides 2 - Plunger guide screws
159	AC switch kit (5-57-5504-00) (brake release interlock switch - N.O.) 1 - AC switch 1 - Mounting screws 2 - Lock washers

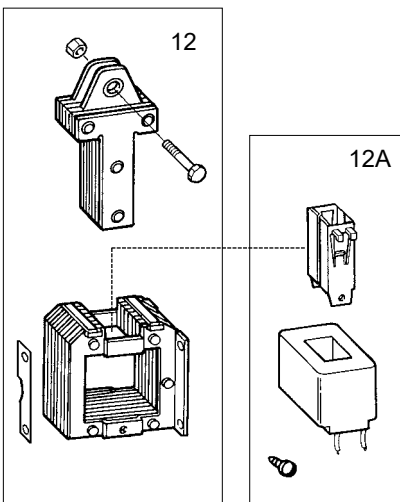

Rexnord Industries, LLC  
Stearns Division  
5150 International Dr.  
Cudahy, Wisconsin 53110  
(414) 272-1100 Fax: (414) 277-4364  
www.stearnsbrakes.com