

Installation & Service Instructions for Series 87,300-01 & 87,300-02

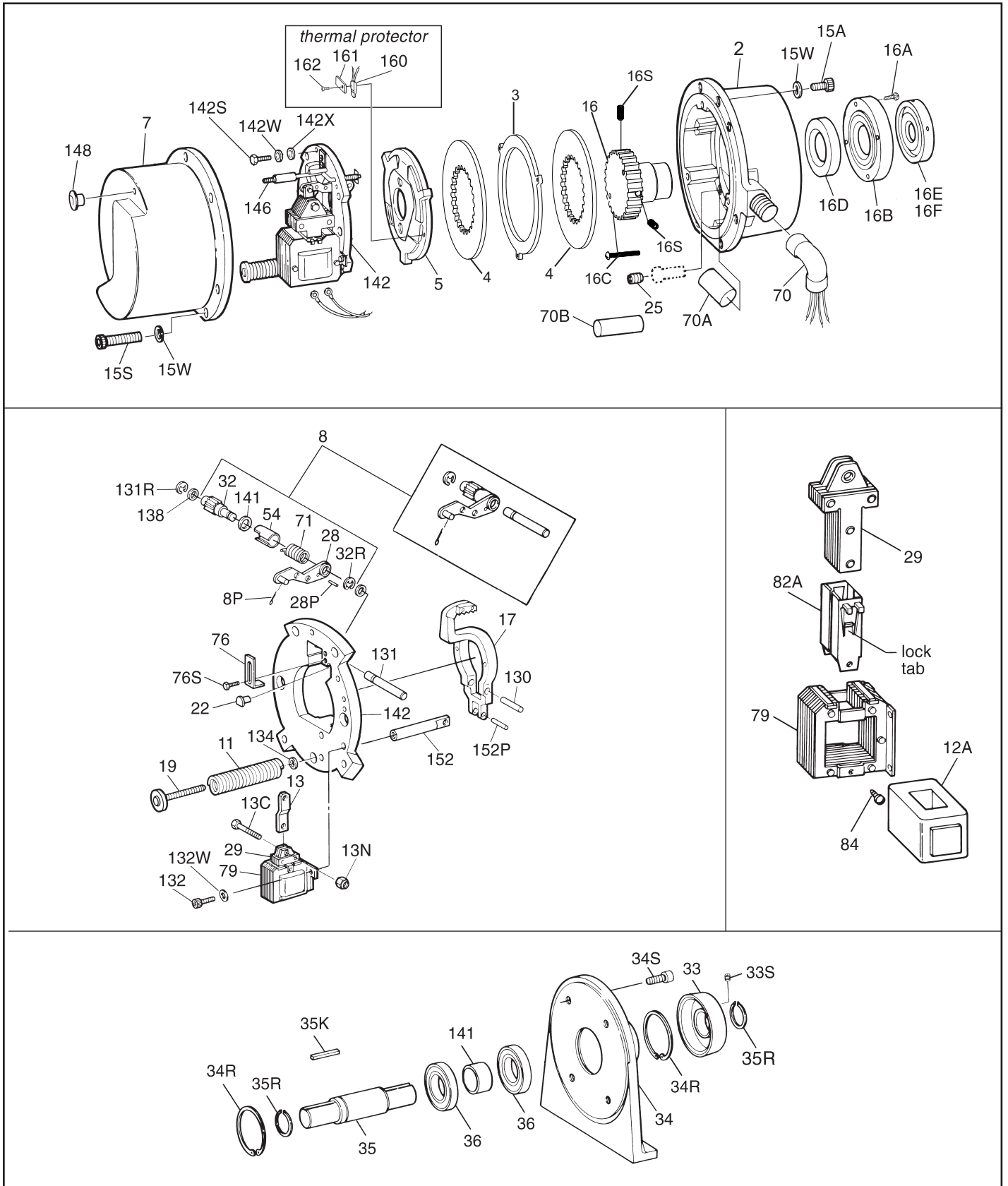

Figure 1

Important

Please read these instructions carefully before installing, operating, or servicing your Stearns Brake. Failure to comply with these instructions could cause injury to personnel and/or damage to property if the brake is installed or operated incorrectly. View the most up-to-date terms and conditions at www.regalrexnord.com/terms-and-conditions-of-sale.

Caution

1. Installation shall be made in compliance with all local safety codes including Occupational Safety and Health Act (OSHA). All wiring and electrical connections must comply with the National Electric Code (NEC) and local electric codes in effect.

2. Do not install brake in a hazardous location other than that as designated.

This brake may not be suitable for use in certain atmospheres containing explosive gases and dusts. **HazLoc** inspection authorities are responsible for verifying and authorizing the use of suitably designed and installed **HazLoc** equipment. When questions arise consult local **Authority Having Jurisdiction (AHJ)**.

3. To prevent ignition of hazardous atmospheres, disconnect the product from the supply circuit before opening. Keep assembly tightly closed when in operation.

Also, to prevent an electrical hazard, disconnect power source before working on the brake. If power disconnect point is out of sight, lock disconnect in the *off* position and tag to prevent accidental application of power.

4. Make certain power source conforms to the requirements specified on the brake nameplate.

5. Be careful when touching the exterior of an operating brake. Allow sufficient time for brake to cool before disassembly. Surfaces may be hot enough to be painful or cause injury.

6. Do not operate brake in hazardous atmosphere with housing removed and supply circuit connected.

7. Installation and maintenance should be performed only by qualified personnel familiar with the construction and operation of the brake.

8. For proper performance and operation only genuine Stearns parts should be used for repairs and replacements.

9. After usage, the brake interior will contain burnt and degraded friction material dust. This dust must be removed before servicing or adjusting the brake.

DO NOT BLOW OFF DUST using an air hose. It is important to avoid dispersing dust into the air or inhaling it, as this may be dangerous to your health.

a) Wear a filtered mask or a respirator while removing dust from the inside of a brake.

b) Use a vacuum cleaner or a soft brush to remove dust from the brake. When brushing, avoid causing the dust to become airborne. Collect the dust in a container, such as a bag, which can be sealed off.

General Description

Stearns Series 87,300 is a spring set, electromagnetically released disc brake. The brake is listed by Underwriters Laboratories, Incorporated for hazardous locations. The Class and Group designation is shown on nameplate. The listing includes two types of brakes, one for attachment to a listed motor at that motor manufacturer's factory and the other type which is complete, and can be mounted on a common base and coupled to a motor. The listing marks on the brake apply only to the brake, not to the driving equipment. In the case of a motor mounted brake neither brake nor motor are listed unless both are listed. The listing marks of both the brake and the motor must be in agreement as to the Class and Group rating.

The brake is essentially designed for holding purposes but may be used for stopping light inertia loads. The actuating mechanism includes a

self-adjust feature to compensate for wear of the friction linings or for thermal expansion. The brake has a single-phase solenoid coil for operating on alternating current only. The nominal static torque is factory set. The brake is not waterproof or dust-tight and protection from the weather and other conditions is required.

Note: Fanguard-mounted brakes requiring IP54 and IP55 protection may require additional sealing measures beyond seals provided with the brake. Pressurized sprays aimed at the fan and brake hub surfaces can result in fluid migration along the motor shaft and keyway, and into the brake. The use of an appropriate sealant, such as RTV, or a *forsheda* seal is advised.

Standard AC NEMA voltage are available in Class A style only. Direct current coils are not available.

Operation

Each brake assembly consists of one to three molded friction discs fitted over a hub attached to or driven by a motor shaft. The friction disc(s) are located alternately between an endplate, stationary disc(s) and a pressure plate. The stationary disc(s) and pressure plate are restrained from rotating by the endplate. A solenoid, lever system, and a pressure spring are located on a support plate. A fitted housing, attached to the endplate, encloses the working parts. The housing also provides location and support for a manual release rod.

The release of the brake occurs when the solenoid coil is energized, causing the solenoid plunger to travel a specified distance and, through the lever system, overcome the pressure spring force. The lever system in its travel disengages from the pressure plate which permits the friction discs to rotate when the motor is energized. When the motor and solenoid coil are de-energized, the pressure spring moves the lever system toward the pressure plate, applying a force to stop the rotation of the friction discs.

The brake is equipped with a manual release rod, which, when activated, sufficiently releases the brake without energizing the solenoid coil,

permitting manual movement of the drive system, however drag may be noted. When the solenoid is energized, the manual release rod returns to its initial position or may be manually reset and permits the brake to set when the solenoid coil is again de-energized.

Note: The motor should not be run with the brake in the manual release position to avoid overheating of friction discs.

Installation Motor Checkout - Motor Mounted Brake

Note 1: It is recommended to check the motor C-face alignment tolerances. The internal flame paths of the brake require close running fits. Exceeding the C-face alignment tolerances (the NEMA Standards) may result in a worn endplate and hub. Premature friction disc wear and rubbing noise may also occur. The face run out should be within .004" F.I.M. (Full Indicator Movement.) The eccentricity of the mounting rabbet should be within .004" F.I.M. The shaft run out should be within .002" F.I.M. Maximum permissible endfloat is .005".

Note 2: The motor shaft length, when using a 10 through 75 lb-ft motor mounted brake, must be 3.50" ± .050". The motor shaft length, when using a 105 lb-ft motor mounted brake, must be 3.75" ± .050". The shaft length is measured from the motor mounting face surface to the end of the shaft. For motor frame adapter modifications, consult factory for shaft length requirements.

Note 3: The motor shaft keyway must start .6" minimum from motor C-face - brake mounting surface (no keyway allowed under the slinger).

Installation (see Figure 1)

Note: For proper operation in the horizontal position, mount brake so that solenoid plunger (29) is above the frame (79) when installed. The brake may be mounted, if specifically modified, vertically above or vertically below the motor. A one disc brake vertically below is not modified. If motor is to be ceiling or horizontally wall mounted, brake must be

oriented so the solenoid plunger is above frame when motor is installed.

Method I - Motor Mounted Brake (see Figure 1)

1. Unscrew manual release knob (148), remove the seven housing screws (15S) and lock washers (15W). Remove the short screw (15A) and lock washer (15W) from opposite side of endplate (2) and thread one housing screw into this hole. Tightening this screw will push housing (7) away from endplate. Support housing as it is removed to avoid bending of manual release rod (146). Remove housing screw used as push-off and install short screw with lock washer, torque to 740 lb-in.
2. Depress solenoid plunger and pull release rod (146) back to lock brake mechanism in manual release position or securely tie down plunger to frame.
3. Disconnect solenoid coil lead wires at solenoid. If brake is supplied with heater it will be necessary to disconnect heater lead wires.
4. Remove entire support plate assembly (142) by evenly unscrewing and removing screws, conical spring washers, and flat washers (142S, 142W, and 142X). Optional switch TSW1, if installed, may be

disconnected at this time as support plate assembly (142) is being separated from the endplate.

5. Disconnect motor cut off thermal protector TSW2 (160). Remove pressure plate (5), friction disc(s) (4), stationary disc(s) (3) and the hub (16). Take note of position of the protector(s).

Note: Vertically mounted brake will have special pins which guide spacer springs and, in some cases, spring washers. Note color coded sequence of springs and location of washers, if used. See *Installation*, Note.

6. Slinger positioning procedure Class II installations only

To install the slinger, back set screws out sufficiently to clear shaft. Slide slinger (16E) on the motor shaft with the slinger lip facing away from the motor. Use (16G) slinger positioning template (one provided) or a dial indicator to position slinger lip face .610" from the motor C-face register and check the slinger face runout. (See *Figure 2*.) When the slinger is properly located, torque both slinger mounting set screws (16F) to 25 lb-in.

7. Loosely attach endplate (2) to the NEMA C-face of the motor using four 1/2-13 socket head cap screws and lock washers (not

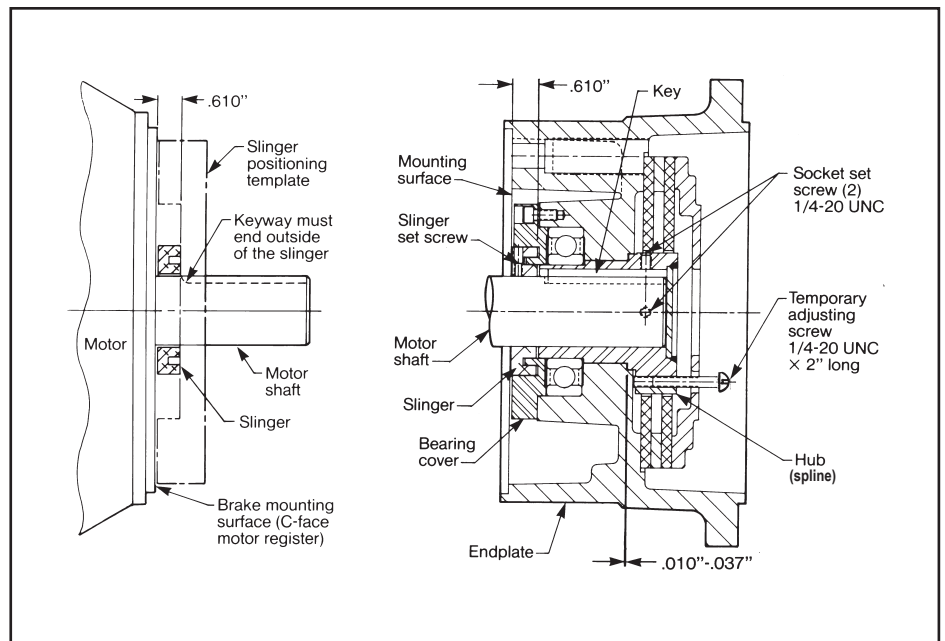

Figure 2

supplied). The endplate mounting register is machined oversize to compensate for possible shaft to bearing misalignment. Thread screws until lock washer tension initially felt.

8. To install the hub, back set screws out sufficiently to clear shaft and key. (**Note:** Top threads of set screw holes are deformed to prevent complete removal.)

Slide the hub onto the shaft without a key initially to insure free movement. The hub will probably stop when it touches the bearing. Very small clearance is provided (.0003"-.0015") between the bearing I.D. and the hub. (The bearing is permanently installed in the endplate.) The endplate may require to be raised to the point where the hub slides into the bearing without force. Rotating the hub while pushing will ease insertion. Endplate mounting vertically above the motor would ease positioning, while holding endplate upwards, snug up the four mounting screws to prevent further endplate movement. The motor shaft is now aligned to the brake endplate bearing. Remove hub.

Reinstall hub with full length key on motor shaft. Push hub into bearing until hub shoulder seats against machined shoulder bore of the endplate while endplate is raised as necessary. Torque the four endplate mounting screws per manufacturers specifications based on material used (545 lb-in for cast iron). Insert the four 1/2-14 pipe plugs (25) and tighten securely.

Note: Be certain that the pipe plugs do not protrude above the endplate friction face.

9. **Hub positioning procedure**
Required is axial clearance .010" to .037", between hub shoulder and machined shoulder of the endplate. It is easily achieved by 1/4-20 UNC screw (16C - provided). See *Figure 2*.

Using 1/4-20 x 2" long screw (one provided), install screw into one of the push out holes on the hub face. Holding the hub firmly

against shoulders, turn the screw in until it firmly touches the endplate, then turn an additional 1/2 turn (180°) to back hub away from endplate. This will provide approximately .025" clearance between these two shoulders. The axial clearance limits .010" (72° turn of 1/4-20 UNC screw) to .037" (270° turn of 1/4-20 UNC screw). Tighten both set screws to 156 lb-in for the square hub, or 288 lb-in for the splined hub. Remove adjusting screw (16C) from the hub.

Note: A small diametrical clearance is maintained between the cylindrical portions of the hub and the endplate, the bearing and the bearing cover. Rotate the hub and check for free rotation without binding or interference with the endplate or the bearing cover.

10. Assemble friction discs, stationary discs and pressure plate in correct sequence and position. If vertical style, reassemble springs plus spacers in proper position and sequence.

Note: Friction discs must be free to slide on hub and the stationary disc(s) and pressure plate must be free to slide in endplate. I.D. of friction discs may require filling to avoid binding on the hub.

11. To protect wire insulation, slide fiberglass tubing (70A) over underside of support plate lead wires and into endplate lead wire outlet hole until it touches the elbow. (See *Figure 3*.)

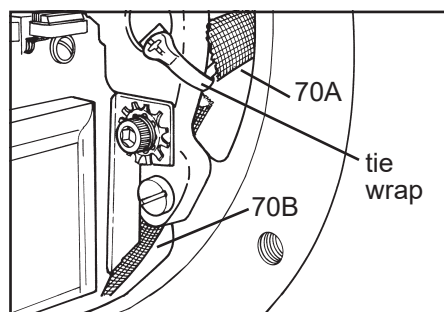

Figure 3

Reconnect motor cut off thermal protector TSW2 and optional TSW1. Be sure wires are not pulled tight, and carefully reroute all wires when mounting support plate, as originally installed.

12. Mount support plate assembly (142) to endplate using screws and conical spring washers (142S and 142W). Flat washer (142X) is installed under the conical spring washer. Torque these screws (142S) to 50 lb-in nominal. Be sure the assembly is mounted with the solenoid plunger above the solenoid frame on horizontally installed brakes. (See *Installation*, Note 1.)

13. Using tie wrap provided, install tie wrap so that wires are held away from pressure plate as shown in *Figure 3*.

14. Disengage manual release rod by depressing plunger sufficiently, to allow release rod to retract or remove plunger tie down.

Note: If release rod is not in manual release position and has allowed the mechanism to overadjust, the support plate will not seat against the endplate. It will have to be reset. In this case the lever arm (17) throat will be near, or touching, the pinion (32) teeth. Loosen pressure spring nut (19) until pressure spring (11) is free. Mount support plate and retighten spring nut, do not overtighten. Lift plunger to maximum travel and release.

15. Manually depress solenoid plunger into the solenoid frame and release, allowing it to snap up. Repeat this process several times to set solenoid air gap. (See *Self-Adjust Maintenance* Section for proper air gap measurement or corrective action for improper gap.)

16. To protect insulation of optional heater and coil leads coming up from the support plate around the solenoid frame and the torque spring, slide fiberglass tubing (70B) over the lead wires.

Replace and/or remake connections on all internal electrical hardware, as originally installed. (See Section on *Electrical Connection of Brake*.)

17. Complete external electrical connection. (See Section on *Electrical Connection of Brake*.)

18. Check that friction disc(s) rotates freely when the solenoid plunger is held firmly against the solenoid frame. If binding or sticking occurs, recheck Steps 6, 7, 8, 9 and 10.
19. Reinstall housing (7) to endplate (2), being careful to guide the manual release rod (146) through hole in the housing. Do not hang the housing from the release rod, as this may bend the rod making it inoperable. Install the housing screws (15S) and short screw (15A) with lock washers (15W) and torque to 740 lb-in.

Note: Since a small diametrical clearance exists between the housing and the endplate, care must be taken that this clearance is maintained. Diameters and surfaces must be free of burrs, nicks and dirt to insure a proper fit.

Method II - Foot Mounted Brake

- The foot mounted brake is factory set and ready to install. Note of *Installation Instructions* applies to foot mounted brakes as well as motor mounted brakes.
- Couple brake directly to output shaft of the drive system. Alignment of the shafts must be within the recommended limits as specified by the coupling manufacturer. The use of dowels is recommended to insure permanent alignment. Do not subject brake shaft (35) to side or overhung loads.
- See *Electrical Connection*. For housing (7) removal see *Installation*, Method I, Item 1.

Electrical Connection of the Brake

CAUTION: Inverter Motor and Special Control Systems. This brake contains either a single phase AC coil or DC coil that requires instantaneous power within $\pm 10\%$ of rating at the coil. A separate power source is required when this brake is used in conjunction with a motor or control system that limits voltage or current input (i.e. inverter motors) or causes a ramping of the power supply.

Note 1: Be sure lead wires to coil

are not tight or pinched, and that leads will not be rubbed by friction disc, trapped between solenoid plunger and frame, caught between lever arm and endplate, or by linkage.

Note 2: On brakes with space heater, connect to appropriate power source. Heater is to be energized continuously, even during storage, to prevent condensation and potential rusting. The Series 87,300 Brake is equipped with an AC single-phase coil. Connect single voltage coil to any two leads on single or three-phase motor of the same voltage as the brake. Refer to brake nameplate and coil number for correct voltage and frequency. The brake can also be wired to external switch contacts, providing proper voltage other than that used to control the motor with the motor and brake contacts interlocked. Method of connecting a dual voltage coil for use on low or high voltage is shown in *Figure 4*. Connect power source to coil terminals.

AC Voltage Coil Connection

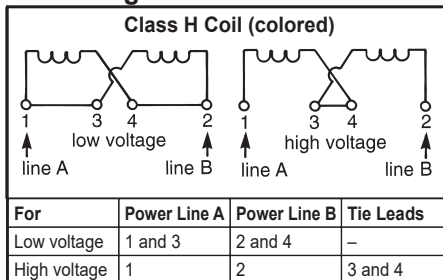

Figure 4

Connecting AC solenoid coils to dual voltage 230/460 three-phase motors

Dual voltage coils are factory preconnected for high voltage with wire nuts. Checking coil connection is suggested. To use a 230 volt coil (or a 230/460 dual voltage coil connected for 230 volts) with a 230/460 dual voltage, three-phase motor, brake leads are connected across two motor terminals as shown in *Figure 5*, or two equivalent combinations. Brake will operate on 230 volts whether motor is connected for 230 or 460 volts.

See *Figure 6* for proper connections of protector switch TSW2, optional warning switch TSW1, optional heater and optional microswitches.

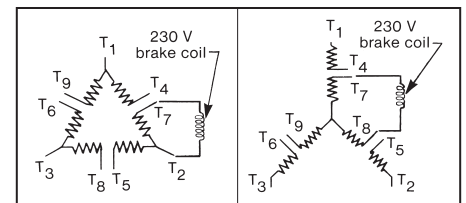

Figure 5

General Maintenance

Warning! Any mechanism or load held in position by the brake should be secured to prevent possible injury or damage to equipment before any disassembly of the brake is attempted or the manual release knob is operated on the brake. Observe all cautions listed at the beginning of this manual.

Note 1: Do not lubricate any parts of the brake.

A. Coil replacement

- For housing removal see *Installation*, Method I, Item 1.
- Disconnect coil leads.
- For 10, 15, 25 and 50 lb-ft brakes, remove solenoid link screw (13C), nut (13N) and lift out solenoid plunger (29).
 - For 35, 75 and 105 lb-ft brakes, remove three mounting screws (132) and lock washers (132W). A hex key with shortened leg is helpful.
- For metallic plunger guides (82), remove plunger guide screws (84). Remove both plunger guides (82) by prying up on the flanges. Replace plunger guides if worn or damaged.
- Slide coil (12A) out from solenoid frame (79) in the direction of the coil terminals. If necessary, tap coil lightly with a soft hammer. If solenoid coil had burned out, be sure to remove all foreign material from the solenoid plunger (29) and solenoid frame (79).
- Install new coil (12A) into solenoid frame with same relative position as old coil. Assemble new metallic plunger guides (82), plunger guide screw(s) (84).
- Reassemble plunger into solenoid by reversing Step 3.
 - For 35, 75 and 105 lb-ft brakes, slide solenoid frame with

WARNING – The thermostats mounted in this brake must be wired into control circuit to limit the brake external surface temperature.

NOTE FOR DUAL VOLTAGE CONNECTION ONLY. Solenoid coil is factory wired for high voltage. Black coil leads 1 and 2, only coil leads extending outside of brake enclosure, always connects to power. For lower rated voltage connection, rewire coil internally per dual voltage diagram on solenoid frame.

Warning device TSW1 indicates the approach of an abnormal high temperature condition. The duty cycle should be reduced when TSW1 opens activating the warning device electrical circuit, indicating an abnormally hot condition. If the warning is not needed and the temperature continues to rise, switch TSW2 will open the motor circuit and cause the brake to set. In moist atmospheres a heater is recommended and should be energized whenever the brake is set.

Color coded lead wires are provided for each microswitch, (SW1 - for brake release and SW2 - for maximum wear indicator). Lead wires are factory wired to N.O. microswitch contacts. Customer may reconnect to N.C. contacts if so desired.

Ratings Vac			
TSW1		TSW2	
Volts	Amps	Volts	Amps
575	1.25	575	1.25
460	1.56	460	1.56
230	3.13	230	3.13
120	6.00	120	6.00

Ratings Vac Optional Heater	
Volts	Watts
120	30
240	30

Ratings for Optional Microswitches	
240 Vac	15A
115 Vdc	.5A

Typical Connection Diagram

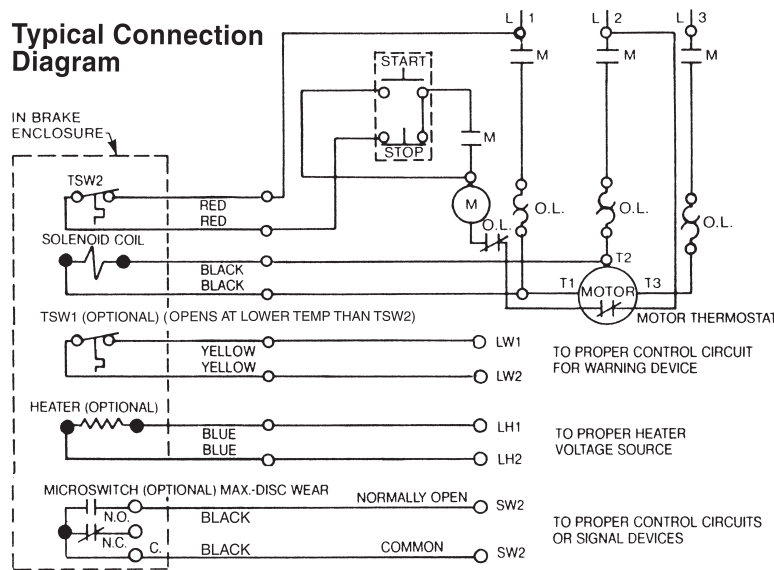

Figure 6

the installed coil over solenoid plunger (29) and attach to support plate assembly (142) with three mounting screws (132) and lock washers (132W). Before tightening mounting screws, align solenoid plunger and solenoid frame so that mating surfaces are parallel. This can be accomplished by manually pulling the plunger down into its sealed position.

b) Tighten the three mounting screws (132) to 50-55 lb-in torque. Be certain that three lock washers (132W) are used.

8. On dual voltage coils, observe the lead numbering sequence

for proper connection. (See *Electrical Connection*.)

9. Be sure lead wires to coil are not tight or pinched; leads must not be rubbed by friction disc; leads must not be trapped between solenoid plunger and frame.

10. Check air gap per *Self-Adjust Maintenance*.

11. Reconnect coil leads.

12. Reinstall housing (7) to endplate (2) per *Installation*, Method I, Step 19.

Caution! Do not run motor with brake in manual release position. It is intended only for emergency manual

movement of the driven load, not as a substitute for full electrical release.

B. Friction disc replacement

Replace friction disc in single disc brakes when wear surface area is one half the original disc thickness (approximately .100 thick). In multiple disc brakes, replace all friction discs when throat of lever arm (17) is within 1/16" of touching the teeth on pinion (32).

Replacement friction discs are available in kits. See *Installation*, Method I, Steps 1 through 5 and 10 through 19.

C. Other standard replacement parts

Piece parts and some kits or assemblies are available.

D. Self-adjust maintenance (see Figure 7)

For housing removal see *Installation*, Method I, Item 1. Since the self-adjust brake automatically adjusts itself for friction disc wear, maintenance is held to a minimum. The solenoid is factory set with a 13/16" to 15/16" air gap, and requires no resetting, even when changing friction discs. Manually lift solenoid plunger to maximum travel. Depress fully and allow solenoid plunger to snap out several times. Measure solenoid air gap between mating surfaces of solenoid frame and solenoid plunger. (On vertically mounted brakes, it will be necessary to push solenoid plunger into solenoid frame to the point where spring pressure is felt, before measuring solenoid air gap.) The gap is determined by the position of wrap spring stop (76). The normal operating gap is 13/16" to 15/16". Should this change, follow the steps listed below:

1. If stop screws (76S) had been loosened and retightened, the air gap may require resetting. The gap is measured between mating surfaces of plunger (29) and solenoid frame (79), and may be increased by raising slightly, or decreased by lowering slightly, wrap spring stop (76). Be sure to retighten stop screws (76S). Manually lift plunger to maximum travel and release. Depress plunger, manually, and allow it to snap up. Repeat several times,

13. A voltage drop may be occurring. If excessive drop in voltage is noted, check wire size of power source. Correct as needed.

Note: A method to check voltage at coil is to insert a block of wood of the approximate thickness of the solenoid air gap between the solenoid frame and plunger. (The block will prevent brake from releasing when coil is energized.) Connect voltmeter leads at the coil terminals or lead wires. Energize coil. Voltmeter needle will not fluctuate and reading can be taken. Reading should be taken immediately and the coil de-energized to prevent overheating of the coil. Compare voltage reading with coil rating. Since brake will be energized during this procedure, be sure a nonexplosive atmosphere exists at time of test or **DO NOT PERFORM!**

14. Check slots of endplate for wear at the areas where stationary discs are located. Grooves in the slots can cause hang-up or even breakage of ears of stationary discs. If grooving is noted, replace endplate.
15. Check that close-up pipe plugs (25) do not extend above wear surface of endplate face.
16. On vertical above brakes, check the vertical mounting pins to be sure shoulder of pin is flush with wear surface of endplate. Be sure pins are straight and the pressure plate and stationary disc(s) are free to slide on the pins. Be sure springs and spacers are installed in proper order. That disc pack slides freely in slots and friction discs slide freely on hub.
17. On vertical below brakes, check that springs and spacers (if used) are installed in proper order. Be sure pins are straight and stationary disc(s) are free to slide on pins. That disc pack slides freely in slots and friction discs slide freely on hub.

18. On foot mounted brakes, recheck alignment and condition of shaft bearings (36). Refer to *Installation Procedure*, Method II, Items 1 and 2.

19. Check that brake coil is energized at the same time as, or prior to, motor and de-energized at the same time, or after, motor.

20. Check pressure spring length to insure correct compressed height. Original spring lengths are given in the following table so that correct setting may be verified and corrected if necessary. With worn friction disc, add amount of wear to spring length shown in next column.

Color	Torque (lb-ft)	Compressed Spring Length
Blue	10	3-5/16"
Yellow	15	3-9/16"
Red	25 & 50	3-3/8"
Green	35, 75 & 105	3-3/8"
Black	10	3-1/4"
White	15	3-1/4"
Orange	25 & 50	3-1/4"
Purple	35, 75 & 105	3-1/4"

21. If a heater is supplied and excess rusting has occurred in brake, check power source to heater to be sure it is operating and that heater is not burned out.
22. If stopping time is more than one second (rule of thumb) and/or the application is more than five stops per minute, check thermal requirements of load versus thermal rating of brake.

If brake hums, solenoid pulls in slowly, or coil burnt out, check the following:

1. Voltage supply at coil versus coil rating.
2. Is solenoid air gap excessive? (See *Self-Adjust Maintenance*.)
3. Shading coils may be broken.

4. Plunger guides may be excessively worn.

Does solenoid plunger rub on solenoid frame laminations? If so, replace plunger guides.

5. Solenoid frame and plunger may be excessively worn.
6. Is solenoid dirty?
7. Solenoid mounting screws may have become loose, causing frame to shift and plunger to seat improperly.
8. Sector gear and pinion teeth may be jamming due to excessive tooth wear.
9. Excessive voltage drop when motor starts. Check size of lead wires for motor starting current and solenoid inrush current. See Step 13 of this Section.

If brake is noisy during stopping:

1. Check mounting face run out, mounting rabbet eccentricity and shaft run out. See *Installation Motor Checkout - Motor Mounted Brake*. Note 1. Correct as required.
2. In cases where motor shaft extends through a fan casing or guard, the clearance hole may not be adequate. Rubbing of the shaft may occur causing a noise during a stop. If required, additional shaft support may be required.
3. Check for bad motor bearings. Replace if necessary. Check for excessive shaft endfloat. Correct as required.