

Installation, Service Instructions & Parts List for 87,800 Series, Division 2 (rev. B)

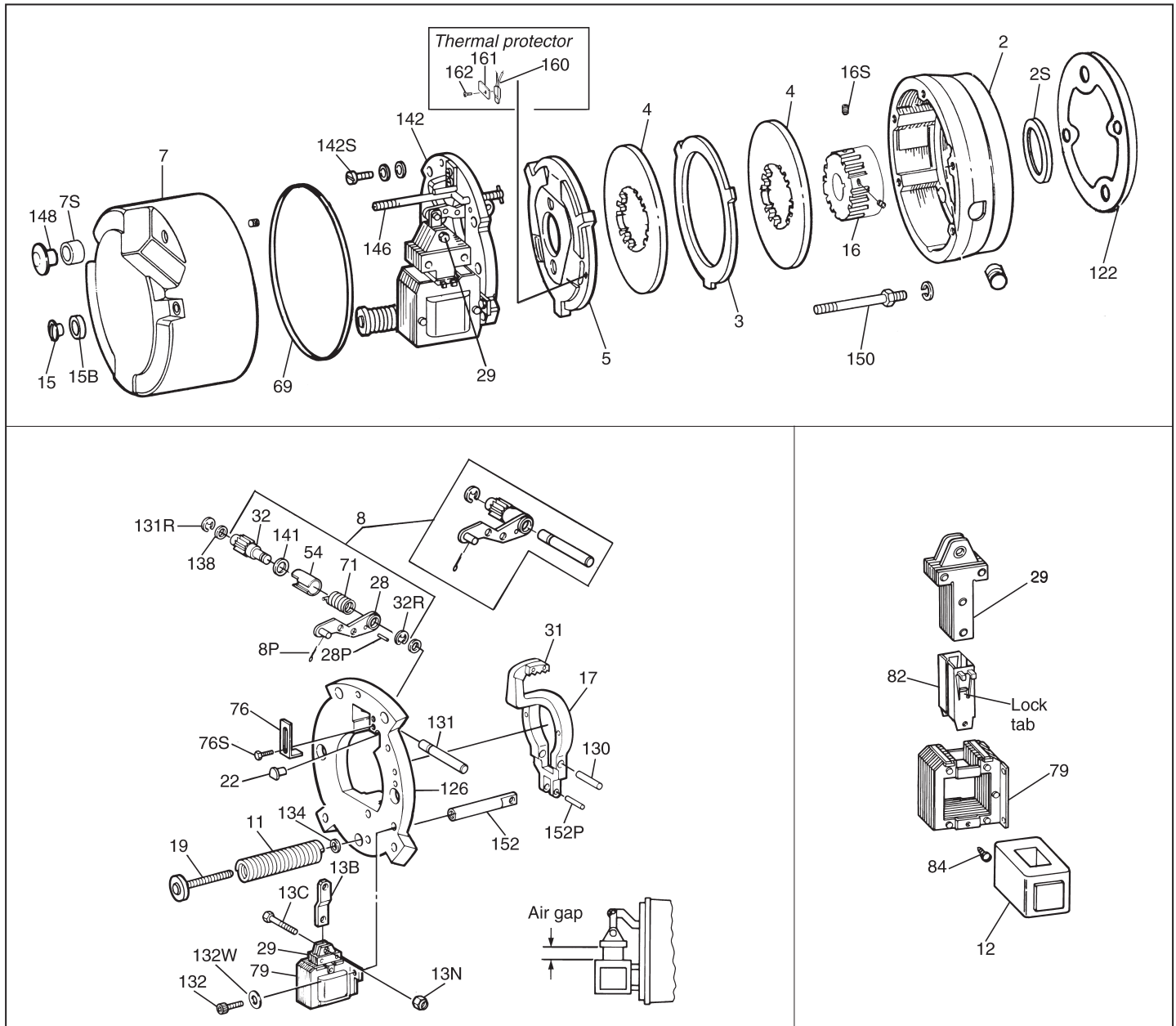

Figure 1

Important

Please read these instructions carefully before installing, operating or servicing your Stearns Brake. Failure to comply with these instructions could cause injury to personnel and/or damage to property if the brake is installed or operated incorrectly. For definition of limited warranty/liability, contact Rexnord Industries, Inc., Stearns Division, 5150 S. International Dr., Cudahy, Wisconsin 53110, (414) 272-1100.

Caution

1. Installation and servicing must be made in compliance with all local safety codes including Occupational Safety and Health Act (OSHA). All wiring and

electrical connections must comply with the National Electric Code (NEC) and local electric codes in effect. For additional information refer to the Underwriters Laboratory (UL) website at: <http://ul.com/hazloc/codes.html>

2. This brake may not be suitable for use in certain atmospheres containingve gases adn dusts. **HazLoc** inspection authorities are responsible for verifying and authorizing the use of suitably designed and installed **HazLoc** equipment. When questions arise consult local **Authority Having Jurisdiction (AHJ)**. To prevent ignition of hazardous atmo-

spheres, disconnect product from supply circuit before opening. Keep assembly tightly closed when in operation.

Also, to prevent an electrical hazard, disconnect power source before working on the brake. If power disconnect point is out of sight, lock disconnect in the *off* position and tag to prevent accidental application of power.

3. Make certain power source conforms to the requirements specified on the brake nameplate.
4. Be careful when touching the exterior of an operating brake. Allow sufficient time for the brake to cool before disassembly. Surfaces may be hot

enough to be painful or cause injury.

5. Do not operate brake in hazardous atmosphere with housing removed and supply circuit connected.
6. Installation and maintenance should be performed only by qualified personnel familiar with the construction and operation of the brake.
7. For proper performance and operation, only genuine Stearns parts should be used for repairs and replacements.
8. After usage, the brake interior will contain burnt and degraded friction material dust. This dust must be removed before servicing or adjusting the brake.
DO NOT BLOW OFF DUST using an air hose. It is important to avoid dispersing dust into the air or inhaling it, as this may be dangerous to your health.
 - a) Wear a filtered mask or a respirator while removing dust from the inside of a brake.
 - b) Use a vacuum cleaner or a soft brush to remove dust from the brake. When brushing, avoid causing the dust to become airborne. Collect the dust in a container, such as a bag, which can be sealed off.
9. Do not run motor with the brake in the manual release position to avoid overheating of friction disc.
10. Do not lubricate any parts of the brake.
11. Do not adjust brake torque. The normal static torque is factory pre-set and should not be altered.

General Description

The 87,800 Series, Division 2 is a spring-set, electrically released disc brake for controlled stopping and holding of a load. It is self-adjusting for friction disc wear and mounts directly to a NEMA C-face motor with 8-1/2" (AK) register and a 7-1/4" (AJ) bolt circle.

The brake is Listed by Underwriters Laboratories, Incorporated for Division 2 - normally not hazardous location. The Class and Group designation is shown on nameplate. The listing includes brakes for attachment to TENV or TEFC motor.

The listing marks on the brake apply only to the brake, not to the driving equipment. In the case of another mounted brake, neither brake nor motor are Listed unless both are Listed. The listing marks of both the brake and the motor must be in agreement as to the Class and Group rating.

Note: Fanguard-mounted brakes requiring IP54 and IP55 protection may require additional sealing measures beyond seals provided with this brake. Pressurized sprays aimed at the fan and brake gub surfaces can result in fluid migration along the motor shaft and keyway, and into the brake. The use of an appropriate sealant, such as RTV, or a *forsheda* seal is advised.

The brake has a single-phase solenoid

coil for operating on alternating current. The nominal static torque is factory set. Standard NEMA voltage coils are available in Class A style only.

Operation

Each brake assembly consists of one to three molded friction discs fitted over a hub attached to or driven by a motor shaft. The friction disc(s) are located alternately between an endplate, stationary disc(s) and a pressure plate. The stationary disc(s) and pressure plate are restrained from rotating by the endplate. A solenoid, lever system, and a pressure spring are located on a support plate. A fitted housing, attached to the endplate, encloses the working parts. The housing also provides location and support for a manual release rod.

The release of the brake occurs when the solenoid coil is energized, causing the solenoid plunger to travel a specified distance and, through the lever system, overcome the pressure spring force. The lever system in its travel disengages from the pressure plate which permits the friction discs to rotate when the motor is energized. When the motor and solenoid coil are de-energized, the pressure spring moves the lever system toward the pressure plate, applying a force to stop the rotation of the friction discs.

The brake is equipped with a manual release rod, which, when activated, sufficiently releases the brake without energizing the solenoid coil, permitting manual movement of the drive system, however drag may be noted. When the solenoid is energized, the manual release rod returns to its initial position or may be manually reset and permits the brake to set when the solenoid coil is again de-energized.

Note: The motor should not be run with the brake in the manual release position to avoid overheating of friction discs.

Installation Procedure - 87,800

1. Remove manual release knob (148) (On pull type), housing nuts (15) & housing (7).
2. Depress solenoid plunger (29) and pull release rod (146) back to lock brake mechanism in manual release position or wire the plunger (29) to frame (79).

Note: For proper operation in the horizontal position, mount brake so that solenoid plunger (29) is above the frame (79) when installed. The brake may be mounted, if specifically modified, vertically above or vertically below the motor. A one disc brake vertically below is not modified. If motor is to be ceiling or horizontally wall mounted, brake must be oriented so the solenoid plunger is above frame when motor is installed.

3. Disconnect solenoid coil lead wires at solenoid. If brake is supplied with heater it will be necessary to disconnect heater lead wires.
4. Remove entire support plate assembly (142) by evenly unscrewing and removing screws, conical spring washers, and flat washers (142S, 142W, and 142X).

Optional switch TSW1, if installed, may be disconnected at this time as support plate assembly (126) is being separated from the endplate.

5. Disconnect motor cut off thermal protector TSW2 (160). Remove pressure plate (5), friction disc(s) (4), stationary disc(s) (3) and the hub (16). Take note of position of the protector(s).
6. Attach endplate (2) to NEMA C-face of motor using four 1/2" diameter socket head cap screws (not supplied) torque per manufacturer's specifications (545 lb-in for cast iron). (Head of cap screws must not project above friction surface.) C-face mounted brakes must be carefully aligned within .004" on concentricity and face runout. Shaft runout should be within .002" T.I.R. Maximum permissible shaft endfloat is .020".

Note 1: Vertically mounted brake will have special pins which guide spacer springs and, in some cases, spring washers. Note color coded sequence of springs and location of washers, if used.

Note 2: If motor is to be ceiling mounted after assembly, entire brake will have to be rotated 180° or "upside down" so it will be positioned with solenoid plunger (29) above frame when final assembly is mounted on ceiling. Similarly, for horizontal wall mounting, rotate 90°.

Note 3: The brake nameplate states mounting position; "horizontal, vertical above or vertical below." The brake must be mounted in that position. Horizontal brakes rated 35 lb-ft and less do not require modification to be mounted vertical below.

Note 4: A dimple drilled into the motor shaft for the hub set screw (16S), 90° from the key is recommended for vertical mounting.

7. Position hub (16) and key (by customer) on the motor shaft so outboard face of hub will protrude approximately 1/32" to 1/16" beyond face of last outboard friction disc. (Position may be determined by assembling friction disc(s) and stationary disc(s) onto hub, noting hub position, and removing disc(s).

Torque set screw (16S) as follows: 3/8 dia. - 24 ft-lb & 1/2 diameter - 52 ft-lb.

8. Assemble friction discs, stationary discs and pressure plate in correct sequence and position. If vertical style, reassemble springs plus spacers in proper position and sequence.

Note: Friction discs must be free to slide on hub and the stationary disc(s) and pressure plate must be free to slide in endplate. I.D. of friction discs may require filing to avoid binding on the hub.

Reconnect motor cut off thermal protector TSW2 and optional TSW1.

Be sure wires are not pulled tight, and carefully reroute all wires when mounting support plate, as originally installed.

9. Mount support plate assembly (142) to endplate using screws and conical

spring washers (142S and 142W). Flat washer (142X) is installed under the conical spring washer. Torque these screws (142S) to 50 lb-in nominal. Be sure the assembly is mounted with the solenoid plunger above the solenoid frame on horizontally installed brakes. (See *Installation Procedure*, Item 2 Note.)

10. Using tie wrap provided, install tie wrap so that wires are held away from pressure plate.
11. Disengage manual release rod by depressing plunger sufficiently, to allow release rod to retract or remove plunger tie down.

Note: If release rod is not in manual release position and has allowed the mechanism to overadjust, the support plate will not seat against the endplate. It will have to be reset. In this case the lever arm (17) throat will be near, or touching, the pinion (32) teeth. Loosen pressure spring nut (19) until pressure spring (11) is free. Mount support plate and retighten spring nut, do not overtighten. Lift plunger to maximum travel and release.
12. Manually depress solenoid plunger into the solenoid frame and release, allowing it to snap up. Repeat this process several times to set solenoid air gap. (See *Self-Adjust Maintenance* Section for proper air gap measurement or corrective action for improper gap.) Replace and/or remake connections on all internal electrical hardware, as originally installed. (See Section on *Electrical Connection of Brake*.)
13. Complete external electrical connection. (See Section on *Electrical Connection of Brake*.)
14. Check that friction disc(s) rotates freely when the solenoid plunger is held firmly against the solenoid frame. If binding or sticking occurs, recheck Steps 6, 7 & 8.
15. Reinstall housing (7) and housing gasket (69) to endplate (2), being careful to guide the manual release rod (146) through seal (7S) in the housing. Do not hang the housing from the release rod, as this may bend the rod making it inoperable. Install the housing screws (15) and O-rings (15B).

Note: To meet the requirements for Class II, Division 2 enclosure, the 87,800 Series Brake must include the following seals and gaskets shown in *Figure 1*:

- a) Manual release rod seal (7S) pressed into brake housing (7).
- b) O-rings (15B) assembled between housing (7) and housing screws (15).
- c) Housing gasket (69) installed between endplate (2) and housing (7).
- d) Hub seal (2S) pressed into endplate (2).
- e) Brake - motor gasket (122) positioned between brake and motor.

When brake is disassembled or had been used for a long period of time, replace deformed or damaged seals and gaskets.

Electrical Connection of the Brake

CAUTION: Inverter Motor and Special Control Systems This brake contains either a single phase AC coil or DC coil that requires instantaneous power within $\pm 10\%$ of rating at the coil. A separate power source is required when this brake is used in conjunction with a motor or control system that limits voltage or current input (i.e. inverter motors) or causes a ramping of the power supply.

Note 1: Be sure lead wires to coil are not tight or pinched, and that leads will not be rubbed by friction disc, trapped between solenoid plunger and frame, caught between lever arm and endplate, or by linkage.

Note 2: On brakes with space heater, connect to appropriate power source. Heater is to be energized continuously, even during storage, to prevent condensation and potential rusting.

The Series 87,800 Brake is equipped with an AC single-phase coil. Connect single voltage coil to any two leads on single or three-phase motor of the same voltage as the brake. Refer to brake nameplate and coil number for correct voltage and frequency. The brake can also be wired to external switch contacts, providing proper voltage other than that used to control the motor with the motor and brake contacts interlocked.

Method of connecting a dual voltage coil for use on low or high voltage is shown in *Figure 2*. Connect power source to coil terminals.

Connecting AC solenoid coils to dual voltage three-phase motors.

To connect a dual voltage coil through the windings of a dual voltage motor, configure the coil to match the low voltage rating of the motor as shown in *Figure 2*. (Single voltage coils should be equal to the low voltage rating of the motor).

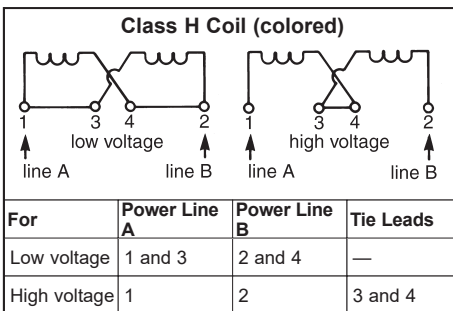

Connect the brake coil across the motor windings as shown in *Figure 3*. Operation of the motor at either voltage will properly operate the brake coil.

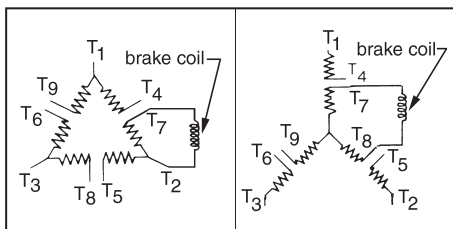

Figure 3

The 87,800 Series Brake, Division 2 is built for attachment to TENV or TEFC motors. Brake operation should not exceed 2 or 5 cycles per minute respectively.

See *Figure 4* (on next page) for proper connections of protector switch TSW2, optional warning switch TSW1, optional heater and optional microswitches.

General Maintenance

Warning! Any mechanism or load held in position by the brake should be secured to prevent possible injury or damage to equipment before any disassembly of the brake is attempted of the manual release knob is operated on the brake. Observe all cautions listed at the beginning of manual.

Note 1: Do not lubricate any parts of the brake.

A. Coil replacement

1. For housing removal see *Installation Procedure*.
2. Disconnect coil leads.
3. For 10, 15, 25 and 50 lb-ft brakes, remove solenoid link screw (13C), nut (13N) and lift out solenoid plunger (29).
 - a) For 35, 75 and 105 lb-ft brakes, remove three mounting screws (132), and lock washers (132W). A hex key with shortened leg is helpful.
4. For metallic plunger guides (82), remove plunger guide screw(s) (84). Remove both plunger guides (82) by prying up on the flanges. Replace plunger guides if worn or damaged.
5. Slide coil (12) out from solenoid frame (79) in the direction of the coil terminals. If necessary, tap coil lightly with a soft hammer. If solenoid coil had burned out, be sure to remove all foreign material from the solenoid plunger (29) and solenoid frame (79).
6. Install new coil (12) into solenoid frame with same relative position as old coil. Assemble new metallic plunger guides (82) and plunger guide screws(s) (84). Install plunger guide screw(s) (84).
7. Reassemble plunger into solenoid by reversing Step 3.
 - a) For 35, 75 and 105 lb-ft brakes, slide solenoid frame with the installed coil over solenoid plunger (29) and attach to support plate assembly (142) with three mounting screws (132) and lock washers (132W). Before tightening mounting screws, align solenoid plunger and solenoid frame so that mating surfaces are parallel. This can be accomplished by manually pulling the plunger down into its sealed position.
 - b) Tighten the three mounting screws (132) to 50-55 lb-in torque. Be certain that three lock washers (132W) are used.
8. On dual voltage coils observe the lead numbering sequence for proper connection. (See *Electrical Connection*).
9. Be sure lead wires to coil are not tight or pinched; leads must not be rubbed by friction disc; leads must not be trapped between solenoid plunger and frame.
10. Check air gap per *Self Adjust Maintenance*.
11. Reconnect coil leads.

WARNING – The thermostats mounted in this brake must be wired into control circuit to limit the brake external surface temperature.

NOTE FOR DUAL VOLTAGE CONNECTION ONLY. Solenoid coil is factory wired for high voltage. Black coil leads 1 and 2, only coil leads extending outside of brake enclosure, always connects to power. For lower rated voltage connection, rewire coil internally per dual voltage diagram on solenoid frame.

Warning device TSW1 indicates the approach of an abnormal high temperature condition. The duty cycle should be reduced when TSW1 opens activating the warning device electrical circuit, and indicating an abnormally hot condition. If the warning is not needed and the temperature continues to rise, switch TSW2 will open the motor circuit and cause the brake to set. In moist atmospheres a heater is recommended and should be energized whenever the brake is set.

Color coded lead wires are provided for each microswitch, (SW1 - for brake release and SW2 - for maximum wear indicator). Lead wires are factory wired to N.O. microswitch contacts. Customer may reconnect to N.C. contacts if so desired.

Ratings VAC			
TSW1		TSW2	
Volts	Amps	Volts	Amps
575	1.25	575	1.25
460	1.56	460	1.56
230	3.13	230	3.13
120	6.00	120	6.00

Ratings VAC Optional Heater	
Volts	Watts
120	30
240	30

Ratings for Optional Microswitches	
240 Vac	15A
115 Vdc	.5A

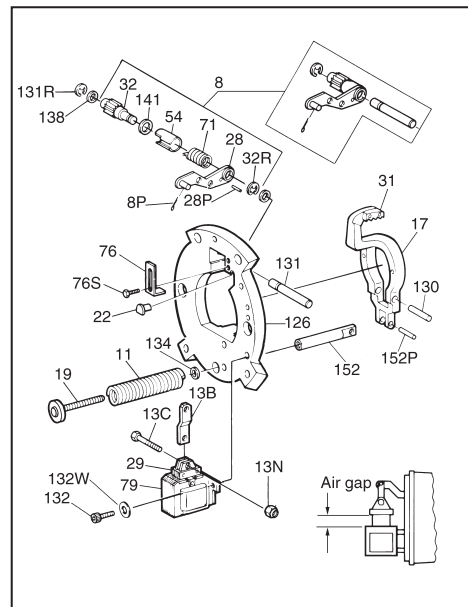

Figure 5

1. If stop screws (76S) had been loosened and retightened, the air gap may require resetting. The gap is measured between mating surfaces of plunger (29) and solenoid frame (79), and may be increased by raising slightly, or decreased by lowering slightly, wrap spring stop (76). Be sure to retighten stop screws (76S). Manually lift plunger to maximum travel and release. Depress plunger, manually, and allow it to snap up. Repeat several times, then recheck air gap. (For vertically mounted brakes, see first part of this Section D.)
2. Tang of wrap spring (71) must be below, and must make contact with wrap spring stop (76) when solenoid lever (28) is manually raised. If stop is bent outward allowing tang to bypass it, rebend to square position, assemble correctly, and reset solenoid air gap as described in Step 1 and this Section.
3. Should air gap disappear, causes are overheating plus oil or other lubricant may have been applied to solenoid lever and pinion assembly (8). Remove support plate assembly (142). Loosen pressure spring nut (19) until pressure spring (11) is free. Remove cotter pin (8P) from solenoid lever (28) and retaining ring (131R) from pivot pin (131). Note location of spacer washer (138) if used, and push pivot pin out to free affected assembly. Remove retaining ring (32R) from pinion (32) and disassemble. Parts should be thoroughly cleaned in a clean solvent that does not leave a film (such as Methyl Ethyl Ketone). Dry all parts thoroughly and reassemble. Be sure that wrap spring (71) is tight against side face of solenoid lever (28), and that end of last turn touched (without preload) the square protruded stop of the solenoid lever. Reassemble in reverse order of steps in this paragraph. Do not retighten cap screw (19) until support plate assembly is mounted on endplate. Refer to Steps 9 through 15 of *Installation Procedure* to complete assembly.
4. Check condition and positioning of pinion (32) and rack (part of lever

Typical Connection Diagram

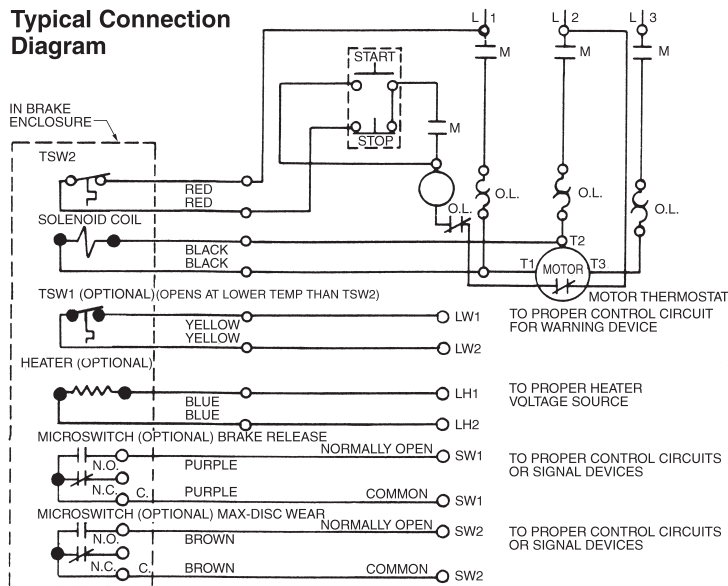

Figure 4

12. Reinstall housing (7) to endplate (2) per *Installation Procedure*, Item 15.

Caution! Do not run motor with brake in manual release position. It is intended only for emergency manual movement of the driven load, not as a substitute for full electrical release.

B. Friction disc replacement

Replace friction disc in single disc brakes when wear surface area is one half the original disc thickness (approx. .100" thick). In multiple disc brakes, replace all friction discs when throat of lever arm (17) is within 1/16" of touching the teeth on pinion (32).

Replacement friction discs are available in kits. See *Installation Procedure*, Items 1 through 5 and 7 through 15.

C. Other standard replacement parts

Replacement part kits for many items are available and contain retrofit instructions.

D. Self-adjust maintenance (see *Figure 5*)

For housing removal see *Installation Procedure*, Item 1. Since the self-adjust brake automatically adjusts itself for friction disc wear, maintenance is held to a minimum. The solenoid is factory set with a 13/16" to 15/16" air gap, and requires no resetting, even when changing friction discs. Manually lift solenoid plunger to maximum travel. Depress fully and allow solenoid plunger to snap up several times. Measure solenoid air gap between mating surfaces of solenoid frame and solenoid plunger. (On vertically mounted brakes, it will be necessary to push solenoid plunger into solenoid frame to the point where spring pressure is felt, before measuring solenoid air gap.) The gap is determined by the position of wrap spring stop (76). Due to wear-in of parts, the normal operating gap is 13/16" to 15/16". Should this change, follow the steps listed below:

arm assembly, 17). Replace parts as necessary with complete assemblies, see following sections.

E. Solenoid lever and pinion assembly replacement

If pinion (32) teeth are worn, replace entire solenoid lever and pinion assembly (8). Consult appropriate parts list for kit number. See disassembly procedure, this Section, Item D3. Check sector gear of lever arm (17) for wear.

F. Lever arm replacement

If sector gear teeth of lever arm (17) are worn, replace entire lever arm assembly. Available as a kit from appropriate repair parts list. Also check pinion (32) teeth for wear.

Note: Refer to Steps 9 through 15 of *Installation Procedure* to complete assembly.

Troubleshooting

(Observe all cautions listed at the beginning of this manual)

A. If brake does not stop properly or overheats check the following:

1. Is manual release engaged, and is motor energized?
2. Friction discs may be excessively worn, charred or broken.
3. Hub may have become loose and shifted on shaft.
4. Is hub clean, and do friction discs slide freely?
5. Are controls which govern start of braking cycles operating properly?
6. Are limit switches, electric eyes, etc, functioning properly?
7. On vertically mounted brakes, are vertical mounting springs and spacers (if used) in place in disc pack?
8. Pressure spring may be improperly assembled or broken.
9. Is solenoid air gap adjusted correctly? (See *D. Self-Adjust Maintenance*.)
10. Check linkage for binding. The approximate pressure applied to the top of the solenoid link to move plunger is:
If excessive force is required, determine cause of binding and correct. Do not overlook bent, worn or broken plunger guides as a possible cause for binding.
11. Solenoid lever stop (22) must be in place on support plate.
12. Solenoid may not be energizing and releasing the brake. Check voltage at the coil and compare to the coil and/or nameplate voltage rating.

#5 coil	3 lbs
#6 coil (15 lb-ft)	5-1/2 lbs
#6 coil (25 lb-ft)	9 lbs
#8 coil	16 lbs

13. A voltage drop may be occurring. If excessive drop in voltage is noted, check, wire size of power source. Correct as needed.

Note: A method to check voltage at coil is to insert a block of wood of the approximate thickness of the solenoid

air gap between the solenoid frame and plunger. (The block will prevent brake from releasing when coil is energized.) Connect voltmeter leads at the coil terminals or lead wires. Energize coil. Voltmeter needle will not fluctuate and reading can be taken. Reading should be taken immediately and the coil de-energized to prevent overheating of the coil. Compare voltage reading with coil rating. Since brake will be energized during this procedure, be sure a non-explosive atmosphere exists at time of test or DO NOT PERFORM!

14. Check slots of endplate for wear at the areas where stationary discs are located. Grooves in the slots can cause hang-up or even breakage of ears of stationary discs. If grooving is noted, replace endplate.
15. Check that close-up pipe plugs (25) do not extend above wear surface of endplate face.
16. On vertical above brakes, check the vertical mounting pins to be sure shoulder of pin is flush with wear surface of endplate. Be sure pins are straight and the pressure plate and stationary disc(s) are free to slide on the pins. Be sure springs and spacers are installed in proper order, and that disc pack slides freely in slots and friction discs slide freely on hub.
17. On vertical below brakes, check that springs and spacers (if used) are installed in proper order. Be sure pins are straight and stationary disc(s) are free to slide on pins, and that disc pack slides freely in slots and friction discs slide freely on hub.
18. On foot mounted brakes, recheck alignment and condition of shaft bearings (36). Refer to *Installation Procedure*.
19. Check that brake coil is energized at the same time as, or prior to, motor and de-energized at the same time, or after motor.
20. Check pressure spring length to insure correct compressed height. Original spring lengths are given in the following table so that correct setting may be verified and corrected if necessary. With worn friction disc, add amount of wear to spring length as shown in table:

Color	Torque (lb-ft)	Compressed Spring Length
Black	10	3-1/4"
White	15	3-1/4"
Orange	25 & 50	3-1/4"
Purple	35, 75 & 105	3-1/4"

21. If a heater is supplied and excess rusting has occurred in brake, check power source to heater to be sure it is operating and that heater is not burned out.
22. If stopping time is more than 1 second (rule of thumb) and/or the application is more than five stops per minute, check thermal requirements of load versus

thermal rating of brake.

B. If brake hums, solenoid pulls in slowly, or coil burn out, check the following:

1. Voltage supply at coil versus coil rating.
2. Is solenoid air gap excessive? (See *D Self-Adjust Maintenance*.)
3. Shading coils may be broken.
4. Plunger guides may be excessively worn. Does solenoid plunger rub on solenoid frame laminations? If so, replace plunger guides.
5. Solenoid frame and plunger may be excessively worn.
6. Is solenoid dirty?
7. Solenoid mounting screws may have become loose, causing frame to shift and plunger to seat improperly.
8. Sector gear and pinion teeth may be jamming due to excessive tooth wear.
9. Excessive voltage drop when motor starts. Check size of lead wires for motor starting current and solenoid inrush current. See Step 13 of this Section.

C. If brake is noisy during stopping:

1. Check mounting face run out, mounting rabbet eccentricity and shaft run out. See *Installation Procedure*, Item 6. Correct as required.
2. Check for signs of the outside diameter of the friction disc(s) or hub rubbing on the inside diameter of the endplate. This would indicate brake is eccentric with respect to the motor shaft and/or the shaft is deflecting during a stop. Check alignment and shaft diameter. Also check for worn motor bearings. If realignment does not correct the problem a larger diameter shaft may be required. Shaft deflection may also be caused by excessive overhang of brake from motor bearing. Additional shaft support may be required.
3. In cases where motor shaft extends through a fan casing or guard, the clearance hole may not be adequate. Rubbing of the shaft may occur causing a noise during a stop. If so, additional shaft support may be required.
4. Check for bad motor bearings. Replace if necessary. Check for excessive shaft endfloat as required.

Parts List for 87,800 Series

Information required when ordering replacement parts:

- Give part number of parts or kits needed, brake model number, and brake serial number. The brake model and serial number may identify special brakes not covered by this parts list.
- When ordering hubs, specify shaft diameter (hub bore) and keyway.
- Circled items are contained in Kit Item A.

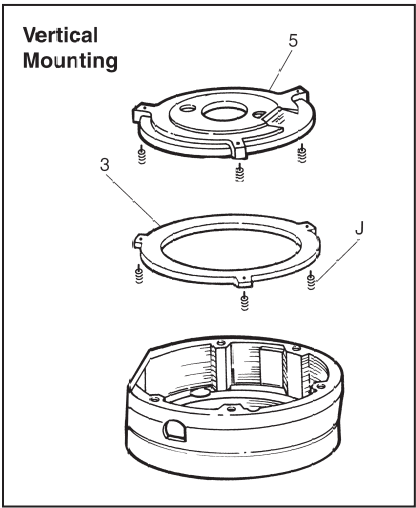
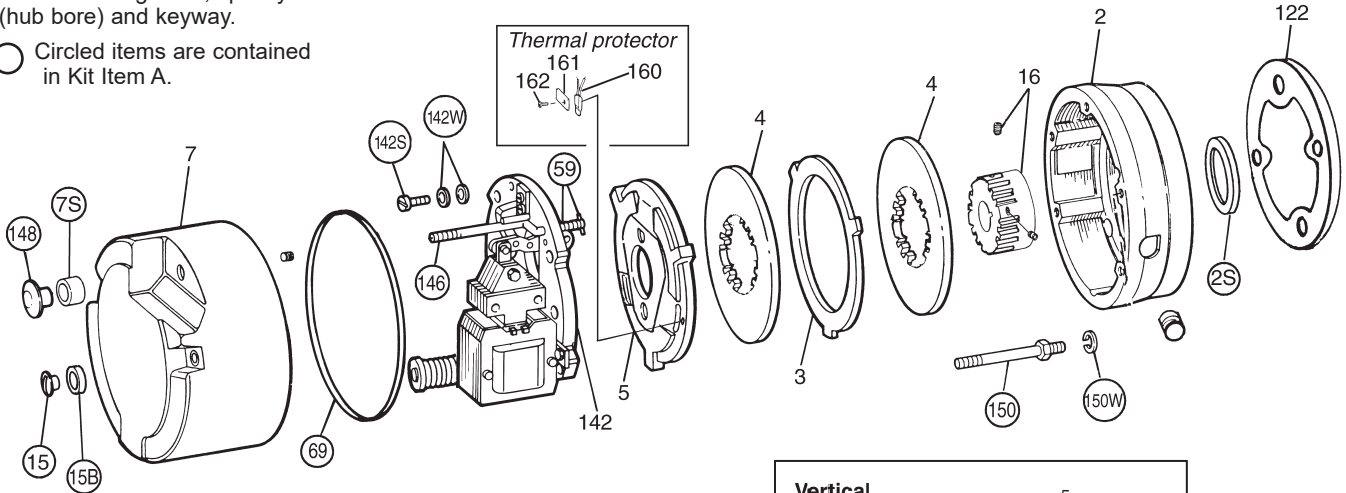

TABLE 1
Components of Standard Brake

Item	Description	Part Number ↓	Torque (lb-ft)							
			6	10	15	25	35	50	75	105
A	Hardware kit	5-66-1007-00	1	1	1	1	1	1	1	1
7	Housing	8-007-735-81	1	1	1	1	1	1	1	1
<i>not shown</i>	Gasket and seat kit	5-66-1281-00	1	1	1	1	1	1	1	1
	Pipe plug (drain) 1/8 NPT	9-33-0325-00	1	1	1	1	1	1	1	1
5	Pressure plate	5-66-8571-00	1	1	1	1	1	1	1	1
4	Friction disc kit - splined	5-66-8483-00		1	1	1	1	2	2	3
3	Stationary disc kit (horizontal and vertical)	5-66-8372-00						1	1	2
160	Thermal protector (TSW2)	9-62-8017-00	1	1	1	1	1	1	1	1
161	Lock plate	8-076-713-00	1	1	1	1	1	1	1	1
162	Screw - lock plate	9-14-2704-00	1	1	1	1	1	1	1	1
16	Hub and set screw assy. (1-disc brake)	5-16-7201-00*	1	1	1	1	1			
	Hub and set screw assy. (2-disc brake)	5-16-7202-00*						1	1	
	Hub and set screw assy. (3-disc brake)	5-16-7203-00*								1
122	Gasket-endplate mounting	8-122-801-00	1	1	1	1	1	1	1	1
2	Endplate and oil seal assy.	5-22-7061-00-30F	1	1	1	1	1			
	Endplate and oil seal assy.	5-22-7063-00-30F						1	1	
	Endplate and oil seal assy.	5-22-7065-00-30F								1
142**	Support plate assy. (AC)	5-42-7089-00	1							
	Support plate assy. (AC)	5-42-7091-00		1						
	Support plate assy. (AC)	5-42-7093-00			1					
	Support plate assy. (AC)	5-42-7095-00				1				
	Support plate assy. (AC)	5-42-7097-00					1		1	1

* Bore diameter or full model number must be given when ordering.

** Coil is separate.

TABLE 2
Components for Vertical Modifications

Item	Description	Part Number ↓	Torque (lb-ft)							
			6	10	15	25	35	50	75	105
			1-087-802-00	1-087-812-00	1-087-822-00	1-087-832-00	1-087-842-00	1-087-852-00	1-087-862-00	1-087-882-00
Vertical Above Modification:										
5	Pressure plate	5-66-8571-00	1	1	1	1	1	1	1	1
3	Stationary Disc	5-66-8372-00						1	1	2
J	Vertical Spring kit	5-66-3176-00	1	1	1	1	1	1	1	1
Vertical Below Modification:										
2	Endplate & seal assy									
	1 disc (cast iron)	5-22-7072-00-30F	1	1	1	1	1			
	2 disc (cast iron)	5-22-7073-00-30F						1	1	
	3 disc (cast iron)	5-22-7074-00-30F								1
5	Pressure Plate	5-66-8571-00	1	1	1	1	1	1	1	1
5	Stationary Disc	5-66-8372-00						1	1	2
J	Vertical Spring kit	5-66-3176-00	1	1	1	1	1	1	1	1

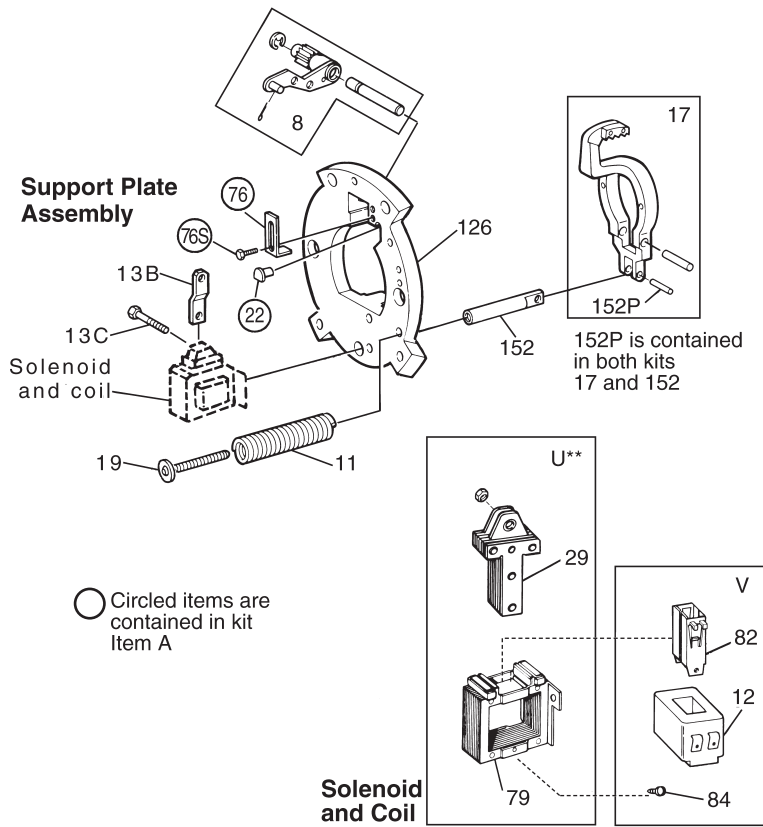

TABLE 3
Components of Support Plate and Coil Assembly

Item	Description	Part Number	Torque (lb-ft)			
			6 10	15	25 50	35 75 105
126	Support Plate and bearing assembly Support Plate and bearing assembly	5-26-7007-00 5-26-7008-00	1	1	1	1
8	Solenoid lever and pinion kit	5-66-7371-00	1	1	1	1
17	Lever arm kit	5-66-7271-00	1	1	1	1
19 & 152	Pressure spring tube kit	5-66-7471-00	1	1	1	1
11	Pressure spring kit - black Pressure spring kit - white Pressure spring kit - orange Pressure spring kit - purple	5-66-3072-00 5-66-3074-00 5-66-3076-00 5-66-3078-00	1	1	1	1
AC Brakes						
U	No. 5 solenoid kit No. 6 solenoid kit No. 8 solenoid kit	5-66-5051-00 5-66-5061-00 5-66-5081-00	1	1	1	1
13B	Solenoid link Solenoid link	8-013-703-00 8-013-704-00	1	1	1	1
13C	Solenoid link cap screw Solenoid link cap screw Solenoid link cap screw	8-157-701-00 8-157-702-00 8-157-703-00	1	1	1	1
V	No. 5 Coil kit 60 Hz	115/230 Vac 230/460 Vac 115 Vac 230 Vac 460 Vac 575 Vac	5-96-6509-25 5-96-6509-27 5-96-6509-20 5-96-6509-24 5-96-6509-26 5-96-6509-29	1 1 1 1 1 1		
	No. 6 Coil kit 60 Hz	115/230 Vac 230/460 Vac 115 Vac 230 Vac 460 Vac 575 Vac	5-96-6609-38 5-96-6609-49 5-96-6609-30 5-96-6609-37 5-96-6609-47 5-96-6609-51	1 1 1 1 1 1	1 1 1 1 1 1	
	No. 8 Coil kit 60 Hz	115/230 Vac 230/460 Vac 115 Vac 230 Vac 460 Vac 575 Vac	5-96-6809-59 5-96-6809-69 5-96-6809-52 5-96-6809-58 5-96-6809-67 5-96-6809-72			1 1 1 1 1 1

TABLE 4
Contents of Kits and Assemblies
(contents may vary)

Item Designation	Kit Description
A	Hardware kit (5-66-1007-00) 2 – External lead wire plugs 1 – Wrap spring stop 2 – Wrap spring stop screws 1 – Solenoid lever stop 3 – Support plate screws 3 – Support plate conical spring washers 3 – Support plate flat washers 2 – Housing studs 2 – Housing stud lock washers 2 – Housing nuts 1 – Release rod 1 – Release rod spring 1 – Release spring retainer 1 – Housing grommet 1 – Release knob
	Gasket and seal kit (5-66-1281-00) 1 – Endplate oil seal 1 – Housing seal 2 – Housing nut gaskets 1 – Housing to endplate gasket 3 – Lead wire bushings 1 – Pipe plug
4	Friction disc kit - splined (5-66-8483-00) 1 – Friction disc - splined
3	Stationary disc kit (5-66-8372-00) 1 – Stationary disc (horizontal or vertical)
5	Pressure plate kit (5-66-8571-00) 1 – Pressure plate (horizontal/vertical)
J	Vertical spring kit (5-66-3176-00) 9 – Vertical mounting springs
8	Solenoid lever and pinion kit (5-66-7371-00) 1 – Solenoid lever and pinion assembly 1 – Cotter pin 1 – Solenoid lever pivot pin 1 – Pivot pin retaining ring
17	Lever arm kit (5-66-7271-00) 1 – Lever arm assembly 1 – Lever arm pivot pin 1 – Spring tube pivot pin
19 and 152	Pressure spring tube kit (5-66-7471-00) 1 – Pressure spring tube 1 – Pressure spring screw 1 – Spring tube pivot pin
11	Pressure spring kit (5-66-307X-00) 1 – Pressure spring
U	Solenoid kit (5-66-50X1-00) 1 – Plunger 1 – Frame 3 – Solenoid mounting screws 3 – Solenoid mtg. conical spring washers 1 – Solenoid link nut
V	Coil kits (5-66-6XXX-33) AC coils 1 – Coil 2 – Plunger guides 2 – Plunger guide screws